



20 TON INDUSTRIAL AC UNIT NEMA 4 & 7

Unit Performance / Data



General

CAT Class	NEMA 4: 718-1500 / NEMA 7: 718-1505
Manufacturer	Custom Air Products & Services, Inc.
Unit Model Number NEMA 4	PPKH-20TD-0NN0NN-5E5-P2-S1CEUP
Unit Model Number NEMA 7	PPKH-20TD-0NN0NN-5B2-P2-S1CEUP
Equipment Insurance Value	\$63,000.00
Duct Connections	1 x 20" Supply Air & 2 x 20" Return Air

Dimensions

Length	107" (8'-11")
Width	79" (6'-7")
Height	83¼" (6'-10")
Unit Weight (N4)	4,500 Lbs.
Unit Weight (N7)	4,600 Lbs.

Electrical

Single Point Power Supply	460V / 3PH / 60HZ
Connections	4 Cam-Lok connectors

Cooling MCA	51
Cooling MOCP	70

Fan Performance

CFM	TSP	MOTOR HP
2,800	7.0	5

Filter

SIZE	EFF.	TYPE
(3) 20" x 20" x 2"	30%	Pleated

For more information contact:

Herc Rentals
www.hercrentals.com
 1 (888) 658-1718



20 TON INDUSTRIAL AC UNIT NEMA 4 & 7

Unit Drawings / Photos

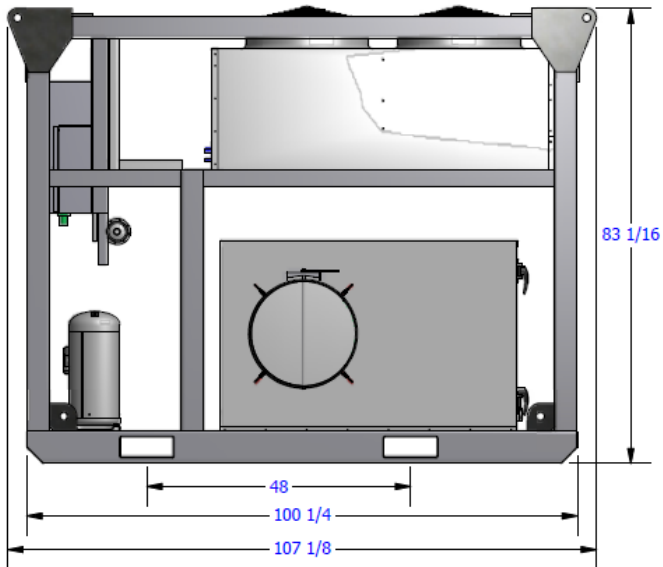

Supply Air View

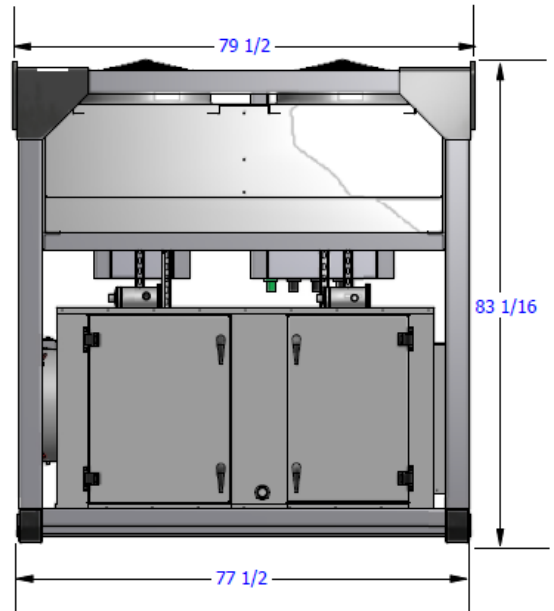

Access Panels View



**Electrical Panel View NEMA 4 Non-Explosion Proof
Stainless Steel Cabinet & Hot Dipped Galvanized
Skid & Cage**

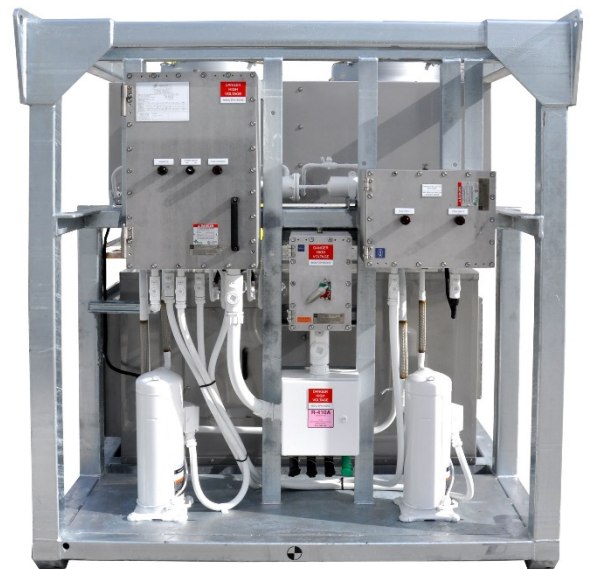

**Electrical Panel View NEMA 7 Explosion Proof
Stainless Steel Cabinet & Hot Dipped
Galvanized Skid & Cage**

For more information contact:

Herc Rentals

www.hercrentals.com

1 (888) 658-1718



20 TON INDUSTRIAL AC UNIT NEMA 4 & 7

Product Data

Air Conditioning Unit Features:

- Two (2) stages of refrigeration capacity control
- Dual independent refrigerant circuits
- Dual circuit hot gas bypass
- 2,800 CFM high static plenum fan rated at 7 TSP
- Direct drive condenser fans
- Environmentally safe 410A refrigerant
- Stainless steel condensate pan
- Dual condensate connections (size 1¼" FPT)
- Easy access panels for efficient serviceability
- Isolated high / low voltage control panels
- Double wall evaporator cabinet construction
- Heavy duty skid, forklift slots, tie-downs with coated lifting / stacking cage (Option: stack and cage to be hot dipped galvanized)
- Rugged design built for rental duty
- Corrosion resistant condenser coil guards
- One (1) 20" outlet & two (2) 20" inlet air duct connections
- 100% outside or return air duty

Air Conditioning Unit Functions:

- NEMA 4 to meet General Purpose Electrical Classification
- NEMA 7 Hazardous electrical classification to meet Class 1, Division 2, Group C & D, T3
- Single point 460V / 3PH / 60HZ power application power connection utilizing four (4) Cam-Lock power cables
- Panel mounted high voltage disconnect
- Main power on indicator light (green)
- Phase monitor and phase fail indicator light (red)
- Circuit # 1 and 2 cooling failure alarm light (red)
- Master On / Off switch
- Low ambient fan cycling control
- High static evaporator fan
- Hour meters for each refrigerant circuit
- DDC compressor protection module
- Common trouble alarm terminal
- High and low pressure safety switches
- Micro processor temperature controller
- Entering and leaving air control capability
- Refrigerant isolation valves, sight glasses and filter driers

For more information contact:

Herc Rentals

www.hercrentals.com

1 (888) 658-1718



20 TON INDUSTRIAL AC UNIT NEMA 4 & 7

Unit Performance/Data

Operating Performance

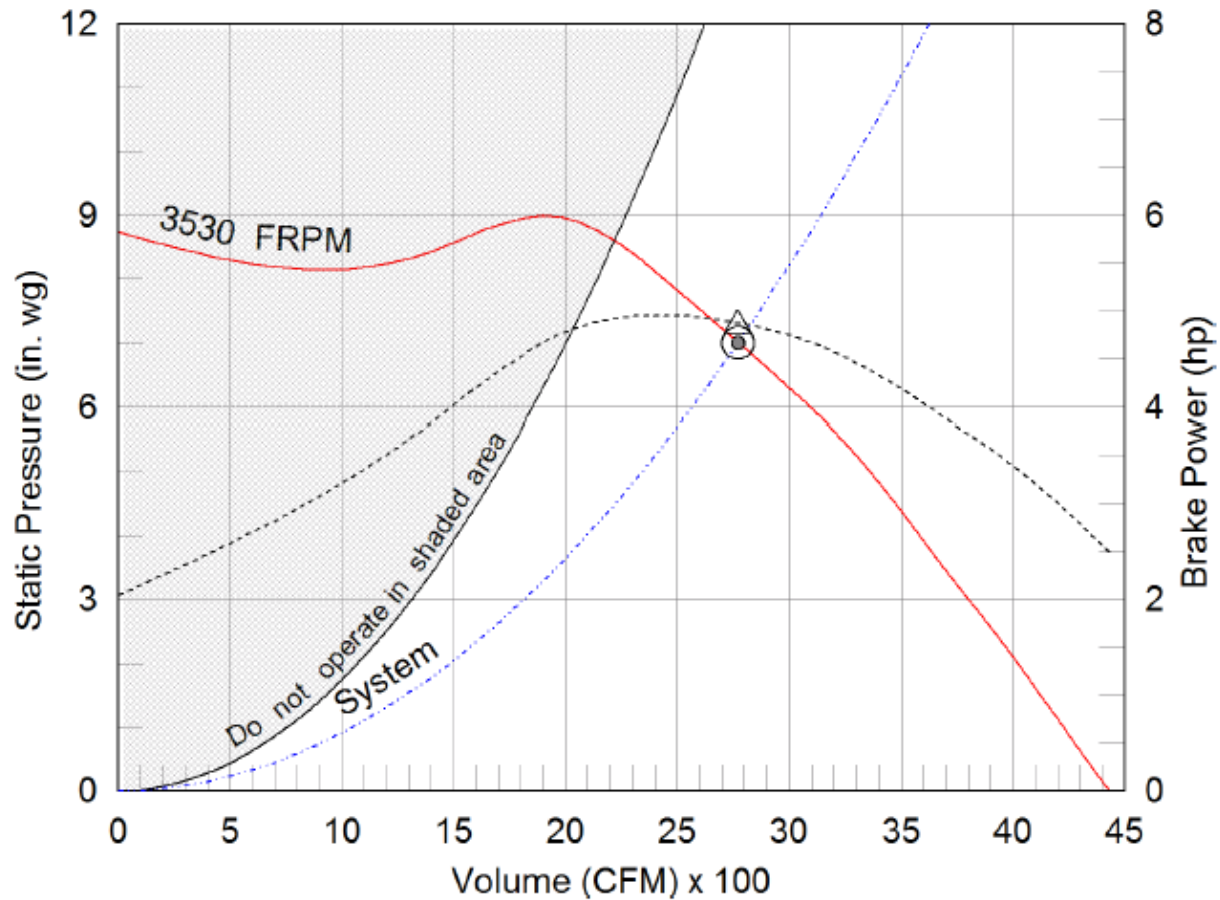

Cooling Coil Performance

CFM	FPM	EDB/EWB	LDB/LWB	MBH Total	MBH Sens.	ROW/F IN	REFG.	SUCT. TEMP	SUPER HEAT
2,800	443	95.0 / 80.0	53.2 / 53.2	258.9	125.2	6 / 13	410A	45.0	20.0

Equipment specifications are based manufactures published data; capacity may vary based upon field conditions

For more information contact:

Herc Rentals

www.hercrentals.com

1 (888) 658-1718