



120 TON PORTABLE AIR COOLED CHILLER PACKAGE

Unit Performance / Data



General

CAT Class	718-2570
Manufacturer	Custom Air Products & Services, Inc.
Unit Model Number	PCHH-120TC-0NN0NN-5E5-0-PG2CEUP
Equipment Insurance Value	\$140,000.00
Filter Requirements	N/A

Chiller Dimensions

Length (Cage)	200" (16'-8")
Length (Base)	204.5" (17'-1/2")
Width	101.5" (8'-5 1/2")
Height	102" (8'-6")
Unit Weight	9,200 Lbs.

Electrical

Certification	ETL/cETL UL Listed equipment and components
Single Point Power Supply	460V/3PH/60HZ
Connections	1 @ Series 16 Male per conductor
Min. Circuit Ampacity (MCA)	277 (MCA must be used for circuit sizing-includes pump)
Max. Overcurrent Protection (MOCP)	300

Evaporator Flow

Water Volume, Gals.	14
Max Water Side Pressure, PSIG	150
Max Refrigerant Side Pressure, PSIG	450
Min Chilled Water Flow Rate, GPM	151
Max Chilled Water Flow Rate, GPM	625

For more information contact:

Herc Rentals
www.hercrentals.com
1 (888) 658-1718

More unit performance data on page 4



120 TON PORTABLE AIR COOLED CHILLER PACKAGE

Unit Drawings / Photos

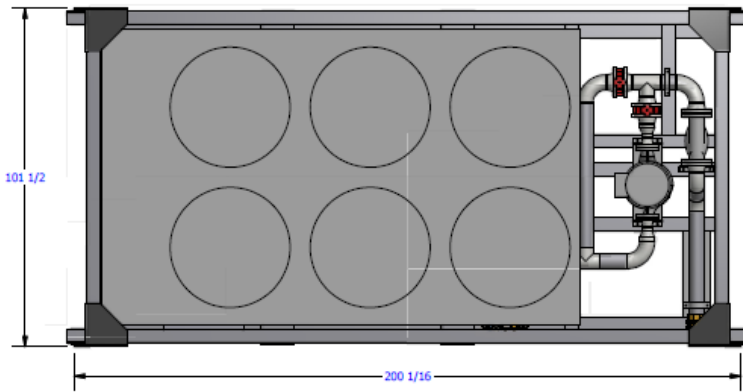

Plan View with Dimensional Data

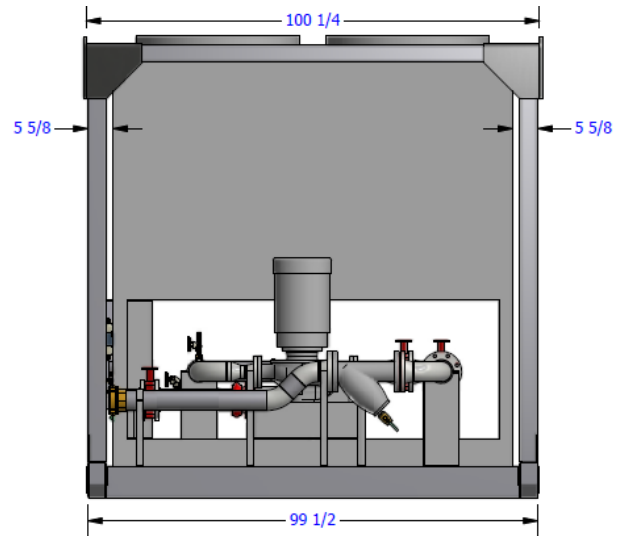

Integrated 300 GPM Pump with Bypass and Dimensional Data

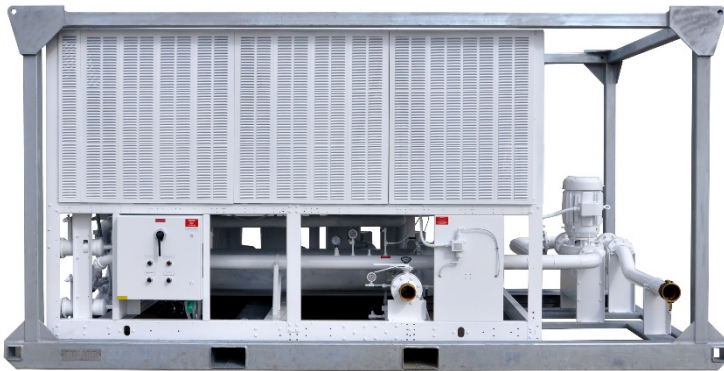

Main Pump Panel and 4" Chilled Water Connections

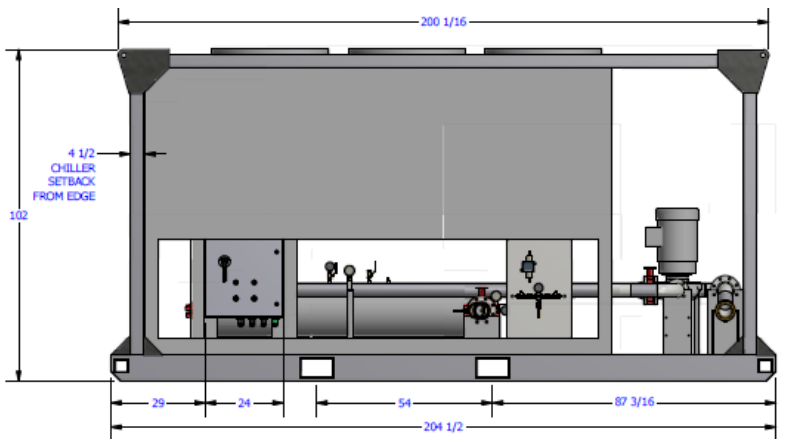

Lifting/Stacking Structural Skid & Cage with Dimensional Data



Integrated 300 GPM Pump With Bypass

For more information contact:
Herc Rentals
www.hercrentals.com
1 (888) 658-1718



120 TON PORTABLE AIR COOLED CHILLER PACKAGE

Product Data

Chiller Features:

- York YLAA0120SE46XFBBXTX air cooled chiller
- TEAO condenser fan motors
- Direct drive suction gas cooled, hermetic, scroll compressors
- Plate and frame heat exchanger
- Super quiet design
- High efficiency/performance
- R410A refrigerant
- Freeze protection to -20F with 3/4" foam insulated evaporator, chilled water heat exchanger heaters, external thermostat control for heaters and refrigerant isolation valves (discharge valve)
- Suitable for high ambient operation up to 125°F with high ambient option
- Suitable for low ambient operation down to 0°F with low ambient option
- Enhanced capacity control with hot gas bypass option
- Dual circuit machine for staging and efficiency
- Louvered condenser coil guards
- Stand-alone York DDC temperature controls
- ETL/cETL listed to US and Canadian safety standard
- CRN Certified For Ontario, Quebec, Alberta and British Columbia
- ASHRAE 90.1 compliance
- ARI Standard 550/590
- ANSI/NFPA Standard 70

Package Features:

- Phase monitor and phase fail indicator light (red)
- Main power on indicator light (green)
- Master On/Off switch
- One (1) hour compressor crank case heater lock out timer
- Common trouble alarm terminal
- Integrated main power wiring with Cam-Lock electrical connections and associated wiring
- Single point 460V/3PH/60HZ power application power connection for Chiller/Pump package
- Additional differential pressure safety switch for chiller protection
- EnergyGuard condenser coil corrosion protection
- Temperature and pressure gauges (Inlet & Outlet)
- Chiller provided with hydronic isolation and drain valves.
- Hot dip galvanized certified structural lifting/stacking skid and integrated tie-downs
- 4" Dixon type quick connect fittings (Inlet & Outlet)
- 4" Butterfly Valve (Inlet & Outlet)
- Chilled water temperature and pressure indication (Inlet & Outlet)
- Integrated 300 GPM @ 100' TDH system pump with bypass for local or remote pump application

For more information contact:

Herc Rentals

www.hercrentals.com

1 (888) 658-1718



120 TON PORTABLE AIR COOLED CHILLER PACKAGE

Unit Performance/Data

MODEL: YLAA0120SE																		IPLV= 14.8	
AIR TEMPERATURE ON - CONDENSER (°F)																			
LCWT (°F)	75.0			80.0			85.0			90.0			95.0			100.0			
	TONS	KW	EER	TONS	KW	EER	TONS	KW	EER	TONS	KW	EER	TONS	KW	EER	TONS	KW	EER	
40.0	126.7	106.1	13.1	123.2	111.7	12.1	119.7	117.5	11.3	116.0	123.9	10.4	112.3	130.5	9.6	107.8	137.1	8.8	
42.0	130.8	107.3	13.4	127.2	112.9	12.4	123.6	118.8	11.5	119.8	125.2	10.6	115.9	131.9	9.8	111.4	138.4	9.0	
44.0	135.0	108.6	13.6	131.3	114.2	12.7	127.5	120.1	11.8	123.6	126.5	10.9	119.7	133.2	10.0	115.0	139.8	9.2	
45.0	137.1	109.3	13.8	133.3	114.9	12.8	129.5	120.8	11.9	125.6	127.2	11.0	121.5	133.9	10.1	116.8	140.5	9.3	
46.0	139.2	110.0	13.9	135.4	115.6	12.9	131.5	121.5	12.0	127.5	127.9	11.1	123.4	134.6	10.2	118.6	141.2	9.4	
48.0	143.4	111.3	14.2	139.5	117.0	13.2	135.6	122.9	12.2	131.4	129.3	11.3	127.3	136.0	10.5	122.3	142.6	9.6	
50.0	147.7	112.7	14.4	143.7	118.4	13.4	139.6	124.5	12.4	135.4	130.8	11.5	131.1	137.5	10.7	126.0	144.1	9.8	

MODEL: YLAA0120SE										IPLV= 14.8	
AIR TEMPERATURE ON - CONDENSER (°F)											
LCWT (°F)	105.0			110.0			115.0				
	TONS	KW	EER	TONS	KW	EER	TONS	KW	EER		
40.0	103.3	144.0	8.0	98.6	151.2	7.3	93.8	158.8	6.7		
42.0	106.7	145.4	8.2	101.9	152.6	7.5	54.8	70.6	8.1		
44.0	110.2	146.7	8.4	105.3	154.0	7.7	56.8	71.1	8.4		
45.0	111.9	147.4	8.5	107.0	154.7	7.8	57.8	71.3	8.5		
46.0	113.7	148.1	8.6	108.6	155.4	7.9	58.8	71.6	8.6		
48.0	117.2	149.6	8.8	112.1	156.9	8.1	60.9	72.1	8.9		
50.0	120.8	151.1	9.0	115.5	158.4	8.2	63.0	72.6	9.1		

Pump Performance

Motor 15 HP
 Motor Type TEFC
 Configuration Vertical In-Line
 Variable Speed N/A
 Gallon Per Min. 300
 Total Discharge Head 100'

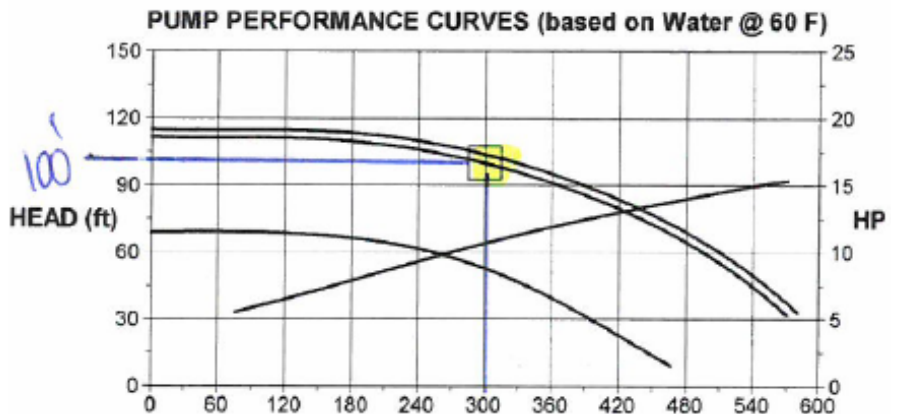

Equipment specifications are based manufactures published data; capacity may vary based upon field conditions

For more information contact:
 Herc Rentals
 www.hercrentals.com
 1 (888) 658-1718