



## 10 TON PACKAGE UNIT GP / NEMA 4

Unit Performance / Data



### General

CAT Class 718-1210  
 Manufacturer Custom Air Products & Services, Inc.  
 Unit Model Number PPKH-10TD-0NN36KE-5E5-P2-G2CEUP  
 Equipment Insurance Value \$24,200.00  
 Duct Connections 1 x 20" Supply Air & 1 x 20" Return Air

### Dimensions

Length 101½" (8'-5")  
 Width 72½" (6')  
 Height 61¼" (5'-1")  
 Unit Weight 2,200 Lbs.

### Electrical

Single Point Power Supply 480V / 3PH / 60HZ  
 Connections 4 Cam-Lok connectors

Cooling MCA 26  
 Cooling MOCP 30

Heating MCA 52  
 Heating MOCP 60

Dehumidification MCA 72  
 Dehumidification MOCP 80

### Fan Performance

CFM	TSP	MOTOR HP
4000	2.2	3

### Heating

kW	STAGES	VOLTAGE
36	2	480 / 3 / 60

### Filter

SIZE	EFF.	TYPE
(4) 24" x 20" x 2"	30%	Pleated

For more information contact:

Herc Rentals  
[www.hercrentals.com](http://www.hercrentals.com)  
 1 (888) 658-1718



## 10 TON PACKAGE UNIT GP / NEMA 4

Unit Drawings / Photos

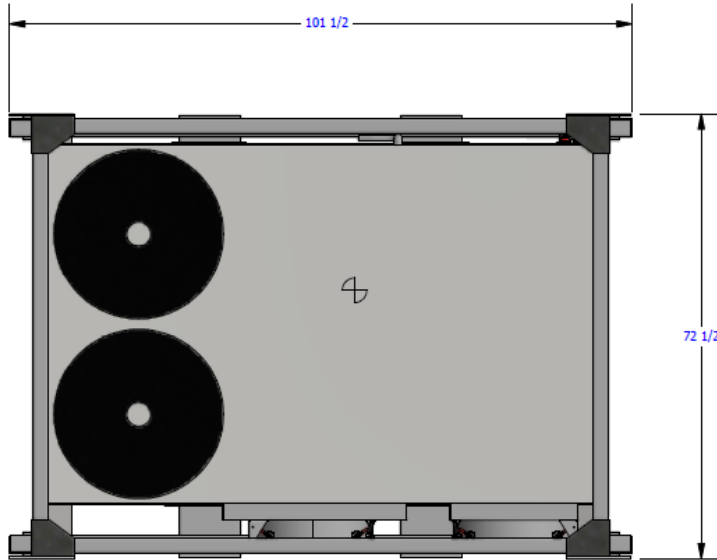

Plan View with Dimensional Data

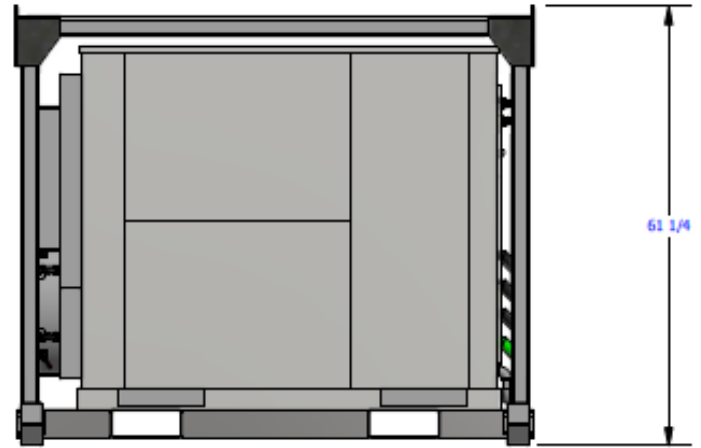

Service Access Side with Dimensional Data



One (1) Supply & One (1) Return Air Connections



Corner View with Condenser Side and Air Connections

For more information contact:  
Herc Rentals  
[www.hercrentals.com](http://www.hercrentals.com)  
1 (888) 658-1718



## 10 TON PACKAGE UNIT GP / NEMA 4

Product Data

### Air Conditioning Unit Features:

- Dual stage of refrigeration capacity control
- 36 kW electric heating elements
- 4,000 CFM fan rated at 2.2 TSP
- Direct drive condenser fans
- Environmentally safe 410A refrigerant
- Resin condensate pan
- Single condensate connections (size 3/4" FPT)
- Easy access panels for efficient serviceability
- Isolated high / low voltage control panels
- Heavy duty skid, forklift slots, tie-downs with coated lifting / stacking cage
- Rugged design built for rental duty
- Corrosion resistant condenser coil guards
- One (1) 20" outlet & one (1) 20" inlet air duct connections
- Unit mounted thermostat
- DH override switch
- Hot gas bypass

### Air Conditioning Unit Functions:

- General purpose electrical classification
- Cooling, Heating and Dehumidification Operation
- Dual point 460V / 3PH / 60HZ power application power connection utilizing four (4) Cam-Lock power cables
- Panel mounted high voltage disconnect
- Main power on indicator light (green)
- Phase monitor and phase fail indicator light (red)
- Master On / Off switch
- Low ambient fan cycling control
- High and low pressure safety switches

**For more information contact:**

**Herc Rentals**

**[www.hercrentals.com](http://www.hercrentals.com)**

**1 (888) 658-1718**

*Rev 0 - 2017*



## 10 TON PACKAGE UNIT GP / NEMA 4

Unit Performance/Data

<b>Cooling Performance</b>	
Total gross capacity	126.0 MBH
Sensible gross capacity	92.5 MBH
Total net capacity	117.2 MBH
Sensible net capacity	83.7 MBH
Efficiency (at ARI)	11.20 EER
Integrated eff. (at ARI)	12.10 IEER
Ambient DB temp.	95.0 °F
Entering DB temp.	80.0 °F
Entering WB temp.	67.0 °F
Leaving DB temp.	58.6 °F
Leaving WB temp.	57.1 °F
Power input (w/o blower)	9.10 kW
Sound power	92 dB(A)
<b>Refrigerant</b>	
Refrigerant type	R-410A
<b>Heating Performance</b>	
Entering DB temp.	60 °F
Heating output capacity (Max)	115.9 MBH
Nominal electric heat	36 kW
Applied electric heat	34.0 kW
Installed	Factory
Supply air	4000 CFM
Leaving DB temp.	86.8 °F
Air temp. rise	26.8 °F
Stages	2
<b>Supply Air Blower Performance</b>	
Supply air	4000 CFM
Ext. static pressure	1.5 IWG
Add. Unit Losses (Options/Accessories)	0.01 IWG
Blower speed	1089 RPM
Max BHP of Motor (including service factor)	3.45 HP
Duct location	Side
Motor rating	3.00 HP
Actual required BHP	2.76 HP
Power input	2.58 kW
Elevation	0 ft.
Drive type	BELT

*Equipment specifications are based manufactures published data; capacity may vary based upon field conditions*

For more information contact:

Herc Rentals

[www.hercrentals.com](http://www.hercrentals.com)

1 (888) 658-1718

Rev 0 - 2017