



CUSTOM AIR PRODUCTS & SERVICES, INC.

35 Southbelt Industrial Drive • Houston, Texas 77047

(713) 460-9009 • Fax (713) 460-9499

www.customairproducts.com

HERC RENTALS

2018 RENTAL FLEET

17F-0861

(2) 10 TON RENTALIZED PACKAGE UNITS

HOT DIPPED GALVANIZED SKID/LIFTING-STACKING

CAGE & 36 KW ELECTRIC HEATER

PPKH-10TD-0NN36KE-HE5-P2-G2CEUP

575V/3PH/60HZ

GENERAL PURPOSE IN/OUT

7/11/2018

INSTALLATION & OPERATION MANUAL

**Table
Of
Contents
17F-0861**

JOB SCOPE	1
10 TON SUBMITTALS	2
ELECTRICAL COMPONENTS	3
ELECTRICAL DRAWINGS	4
MECHANICAL DRAWINGS	5
SPARE PARTS LIST	6



CUSTOM AIR PRODUCTS & SERVICES, INC.

35 Southbelt Industrial Drive • Houston, Texas 77047

(713) 460-9009 • Fax (713) 460-9499

www.customairproducts.com

SECTION

01

JOB SCOPE



Quote No:	DW17-11-08-15
Quote Date:	11-08-2017
Project Type:	(2) 10 Ton AC General Purpose Package Unit with Lifting Stacking Cage & 36 kW Heat (575 Volt)
Drawing Delivery:	2 weeks after receipt of order
Equipment Delivery:	12-14 weeks After Receipt of Approved Drawings (ARAD)
Freight Terms:	FOB HERC
Payment Terms:	Net 45 *100% upon completion

Item	Qty	Description
1.	2	<p>Provide the labor and material to modify one (1) factory package unit for rental industry application with hot dipped galvanized certified lifting stacking cage:</p> <p>CAPS Model #: PPKH-10TD-ONN36KE-HE5-P2-G2CEUP</p> <ul style="list-style-type: none"> • Provide one (1) 10 ton commercial package unit with 36 kW heat: <ul style="list-style-type: none"> ○ Two-stage compressor model ○ 575-3-60 ○ Environmental friendly R410A refrigerant ○ 11.2 EER energy rating ○ 2 stage cooling controls ○ 36kW electric heat is included ○ High static belt drive fan ○ 2" filters ○ Al/Cu evaporator coil construction ○ Simplicity SE controller with discharge air, return air and outside air sensor ○ Composite drain pan ○ Base electro-mechanical controls • The certified skid shall be fabricated from steel tubing and / or channel. The skid size is length and width plus piping so that no part of the unit is outside of the skid. The fork truck lifting slots are made of the same steel tubing and are incorporated into the design on fork slots on all sides. The skid components are continuously welded at all joints. All tubing ends are capped and continuously welded. • The certified lifting frame shall be fabricated from steel tubing. This frame is designed for certified overhead lifting and stacking of the units. All tubing ends are capped and continuously welded. The tubing is cut and fit to the height, width, and length of the unit. All corners have a 45 degree, steel plate gusset. The top of the frame has a steel plate superman gusset welded to the horizontal tubing.

Item	Qty	Description
		<ul style="list-style-type: none"> • The entire skid and cage assembly shall be provided with a hot dipped galvanized coating process. • The following electrical components shall be factory installed and wired per approved wiring diagram furnished by CAPS. <ul style="list-style-type: none"> ○ Main power disconnect switch ○ Phase monitor ○ Power light ○ Phase incorrect light ○ Hour meter ○ 2 stage thermostat ○ Fridge dry / DH override switch ○ Master system switch (off/on) • All electrical components, wire, and electrical material shall be furnished by CAPS. • The package unit shall be provided with a single point Camlok electrical connection (dual "series" feed), power on light, phase incorrect light and on/off switch located on the exterior panel. • The exterior of the unit shall be provided with the standard Herc required exterior cabinet color. Any CAPS provided accessories; hardware and components mounted to the exterior of the cabinet shall be painted to match the standard Herc painting specification. • Evaporative and condenser coils shall be coated with EnergyGuard. • Units shall be furnished with one (1) 20" supply and one (1) 20" return duct collars constructed of galvanealed steel. All corners shall be continuously welded to prevent leakage. • Each duct collar shall be furnished with a cap that is attached with a stainless steel hinge. • Each duct collar shall be furnished with (4) stainless steel duct clamps to hold flex duct in place. • Each cap shall be held closed with (2) rubber hood type latches and be lined with a 1/8" gasket. Each duct cap shall have a latching device to hold it in the open position. • Provide and install condenser coil guards. • CAPS will install the Herc decal package as per provided layout drawing by Herc. • Herc Representatives will also have full access to schedules and production progress as units are being manufactured. • Units will be tested, logged and documented at CAPS facility with Herc personnel welcome during testing if required.
		<p><u>EXCLUSIONS</u></p> <ul style="list-style-type: none"> • Site Installation, Equipment and Start-up Commissioning by others • Sales tax not included • Condensate pump • Freight not included • Overtime not included • Proposal valid for 30 days • Any items not listed in the above scope of work to be performed



CUSTOM AIR PRODUCTS & SERVICES, INC.

35 Southbelt Industrial Drive • Houston, Texas 77047
(713) 460-9009 • Fax (713) 460-9499
www.customairproducts.com

SECTION

02

10 TON SUBMITTALS



SUBMITTAL DATA

For: Approval

Order #: **Date:** 02/03/2016
Project: Meridian 10 Ton Pkg Units 575V
Project #:
Location:

Date

02/03/2016

Project Name

Meridian 10 Ton Pkg Units 575V

Project Number

Client / Purchaser



Submittal Summary Page

Qty	Tag #	Model #	Description
2		J10ZFE36D5A1BAD1A2	<p>10 Ton, Two Staged Cooling, Single Packaged R-410A Air Conditioner, Standard Efficiency, 11.2 EER / 12.1 IEER (CV) / 14 IEER (Intellispeed) / 12.1 IEER (VAV), 36 kW Factory Installed Electric Heat, 575-3-60</p> <ul style="list-style-type: none"> • No Factory Installed Economizer • 3 HP High Static Belt Drive Blower • Standard 2" Throwaway Filters • Simplicity® SE Controller including Discharge Air, Return Air, and Outdoor Air Temperature Sensors • Phase Monitor • Micro-Channel "all-aluminum" condenser coil, Copper tube/aluminum fin evaporator coil • Standard Cabinet with Composite Drain Pan • Hot Gas Bypass
2		1CG0419	Coil Guard

Equipment start-up and commissioning by a factory trained technician is recommended.
 Contact your supplying distributor or sales representative for additional information & guidance.

Single Package R-410A Air Conditioner

Project Name: **Meridian 10 Ton Pkg Units 575V**

Unit Model #: **J10ZFE36D5A1BAD1A2**

Quantity: **2**

System: **J10ZFE36D5A1BAD1A2 (2)**

Cooling Performance

Total gross capacity	126.0 MBH
Sensible gross capacity	92.5 MBH
Total net capacity	117.2 MBH
Sensible net capacity	83.7 MBH
Efficiency (at ARI)	11.20 EER
Integrated eff. (at ARI)	12.10 IEER
Ambient DB temp.	95.0 °F
Entering DB temp.	80.0 °F
Entering WB temp.	67.0 °F
Leaving DB temp.	58.6 °F
Leaving WB temp.	57.1 °F
Power input (w/o blower)	9.10 kW
Sound power	92 dB(A)

Refrigerant

Refrigerant type	R-410A
------------------	--------

Heating Performance

Entering DB temp.	60 °F
Heating output capacity (Max)	115.9 MBH
Nominal electric heat	36 kW
Applied electric heat	34.0 kW
Installed	Factory
Supply air	4000 CFM
Leaving DB temp.	86.8 °F
Air temp. rise	26.8 °F
Stages	2

Supply Air Blower Performance

Supply air	4000 CFM
Ext. static pressure	1.5 IWG
Addl. Unit Losses (Options/Accessories)	0.01 IWG
Blower speed	1089 RPM
Max BHP of Motor (including service factor)	3.45 HP
Duct location	Side
Motor rating	3.00 HP
Actual required BHP	2.76 HP
Power input	2.58 kW
Elevation	0 ft.
Drive type	BELT

Electrical Data

Power supply	575-3-60
Unit min circuit ampacity	45.4 Amps
Unit max over-current protection	50 Amps

Dimensions & Weight

Hgt	51 in.	Len	89 in.	Wth	59 in.
Weight with factory installed options					1105 lbs.

Clearances

Right	12 in.	Front	36 in.	Back	36 in.
Top	72 in.	Bottom	0 in.	Left	36 in.

Note: Please refer to the tech guide for listed maximum static pressures



10 Ton

- JCI Series 10 units are manufactured at an ISO 9001 registered facility and each rooftop is completely computer-run tested prior to shipment.

Unit Features

- Standard Cabinet with Composite Drain Pan
- Two Staged Cooling
- 36 kW Factory Installed Electric Heat
- Either supply and/or return can be field converted from vertical to horizontal configuration without cutting panels.
- Unit Cabinet Constructed of Powder Painted Steel, Certified At 1000 Hours Salt Spray Test (ASTM B-117 Standards)
- Full perimeter base rails with built in rigging capabilities
- Reciprocating Compressor
- Slide-out Blower/3 HP Belt Drive Motor Assembly
- Unit Ships with 2" Throwaway Filters with a Standard Filter Rack that will Accept up to 4" Filters
- Replacement Filters: 4 - (24" x 20"). Unit accepts 2" or 4" wide filters.
- Solid Core Liquid Line Filter Driers
- Short Circuit Current: 5kA RMS Symmetrical
- Through-the-Curb and Through-the-Base Utility Connections
- Single Point Power Connection
- Micro-Channel "all-aluminum" condenser coil, Copper tube/aluminum fin evaporator coil
- Hinged Access Panels
- Hot Gas Bypass

Standard Unit Controller: Simplicity Control Board

- Safety Monitoring - Monitors the high and low-pressure switches, the freezestats, the gas valve, if applicable, and the temperature limit switch on gas and electric heat units. The unit control board will alarm on ignition failures, safety lockouts and re
- An Integrated Low-Ambient Control, Anti-Short Cycle Protection, Lead-Lag, Fan On and Fan off Delays, Low Voltage Protection, On-Board Diagnostic and Fault Code Display. Allows all units to operate in the cooling mode down to 0 °F outdoor ambient without

BAS Controller

- Simplicity SE Controller including Discharge Air, Return Air, and Outdoor Air Temperature Sensors

Warranty

- One (1) Year Limited Warranty on the Complete Unit
- Five (5) Year Warranty - Compressors and Electric Heater Elements



Series 10 (3-12.5 Ton Package) N524

Single Package R-410A Air Conditioner

Project Name: Meridian 10 Ton Pkg Units 575V

Unit Model #: J10ZFE36D5A1BAD1A2

Quantity: 2

System: J10ZFE36D5A1BAD1A2 (2)

Factory Installed Options

J10ZFE36D5A1BAD1A2

Nominal Cooling Capacity:	J10	10 Ton Two Staged Cooling
Product Category:	ZF	Single Packaged R-410A Air Conditioner, Standard Efficiency 11.2 EER / 12.1 IEER (CV) / 14 IEER (Intellispeed) / 12.1 IEER (VAV)
Heat Type and Nominal Heat Capacity:	E36	36 kW Factory Installed Electric Heat
Airflow:	D	3 HP High Static Belt Drive Blower
Voltage:	5	575-3-60
Economizer / Damper:	A	No Factory Installed Economizer
Service Options:	1	
Sensor Options:	B	
Controls:	A	Simplicity® SE Controller including Discharge Air, Return Air, and Outdoor Air Temperature Sensors
Refrigeration:	D	Micro-Channel "all-aluminum" condenser coil, Copper tube/aluminum fin evaporator coil
Additional Options:	1	Standard 2" Throwaway Filters Phase Monitor Hot Gas Bypass
Cabinet Options:	A	Standard Cabinet with Composite Drain Pan
Product Generation:	2	

Field Installed Accessories

Project Name: **Meridian 10 Ton Pkg Units 575V**

Unit Model #: **J10ZFE36D5A1BAD1A2**

Quantity: **2**

System: **J10ZFE36D5A1BAD1A2 (2)**

Consolidated Drawing

NOTES:

1. FOR OUTDOOR USE ONLY.
2. WEIGHTS SHOWN ARE FOR COOLING ONLY UNITS.
3. MIN. CLEARANCES TO BE:
 RIGHT SIDE: 12 [305]
 LEFT SIDE: 36 [915]
 FRONT: 36 [915]
 REAR: 36 [915]
 TOP: 72 [1830]
 BOTTOM: 0 [0]
4. TO REMOVE THE SLIDE-OUT DRAIN PAN, A REAR CLEARANCE OF 60 in (1525 mm) IS REQUIRED. IF SPACE IS UNAVAILABLE, THE DRAIN PAN CAN BE REMOVED THROUGH THE FRONT BY SEPARATING THE CORNER WALL.
5. FOR SMALLER SERVICE AND OPERATIONAL CLEARANCES CONTACT YOUR APPLICATION ENGINEERING DEPARTMENT.
6. DOWNFLOW DUCTS DESIGNED TO BE ATTACHED TO ACCESSORY ROOF CURB ONLY. IF UNIT IS MOUNTED SIDE SUPPLY, IT IS RECOMMENDED THAT THE DUCTS ARE SUPPORTED BY CROSS BRACES, AS DONE ON ACCESSORY ROOF CURBS.
7. SIDE DUCT FLANGES ARE 0.75" HIGH. BOTTOM DUCTS DO NOT HAVE FLANGES.
8. MINIMUM CONDENSATION TRAP HEIGHT SHALL BE 1.5 TIMES THE LOWEST NEGATIVE STATIC.
9. DIMENSIONS IN [] ARE IN MILLIMETERS OR KILOGRAMS.
10. OPTIONAL COIL GUARDS, POWER EXHAUST, GAS HEAT, ECONOMIZER, DISCONNECT SWITCH, CONVENIENCE OUTLET, AND BAROMETRIC RELIEF AND FRESH AIR HOODS SHOWN. EXCEPT XP (HEAT PUMP) UNITS.

TONNAGE	UNIT	OPERATING WEIGHT (LBS) (BASE UNIT)	CENTER OF GRAVITY LOCATION (BASE UNIT)		4 POINT CORNER LOADS (LBS) (BASE UNIT)			
			X	Y	A	B	C	D
8.5	ZF	1007 [458]	38 [965]	24 [610]	235 [107]	175 [79]	255 [116]	342 [155]
10	ZF	1103 [501]	38 [965]	24 [610]	257 [117]	192 [87]	279 [127]	375 [170]
8.5	ZH	1030 [467]	38 [965]	24 [610]	240 [109]	179 [81]	261 [118]	350 [159]
10	ZH	1090 [494]	38 [965]	24 [610]	254 [115]	189 [86]	276 [125]	371 [168]
6.5	ZJ	1030 [467]	39 [991]	25 [635]	245 [111]	191 [87]	260 [118]	333 [151]
7.5	ZJ	1050 [476]	39 [991]	25 [635]	250 [113]	195 [89]	265 [120]	340 [154]
8.5	ZJ	1060 [481]	38 [965]	24 [610]	247 [112]	184 [84]	268 [122]	360 [163]
10	ZJ	1070 [485]	39 [991]	24 [610]	245 [111]	191 [87]	278 [126]	357 [162]
8.5 & 10	ZR	1200 [544]	38 [965]	25.5 [648]	297 [135]	221 [100]	291 [132]	390 [177]
6.5	XP	1080 [490]	38 [965]	25 [635]	262 [119]	195 [89]	266 [121]	357 [162]
7.5	XP	1090 [494]	38 [965]	23 [584]	243 [110]	181 [82]	284 [129]	381 [173]
8.5	XP	1137 [516]	38 [965]	25.5 [648]	282 [128]	210 [95]	276 [125]	370 [168]
10	XP	1135 [515]	38 [965]	25.5 [648]	281 [127]	209 [95]	275 [125]	369 [167]

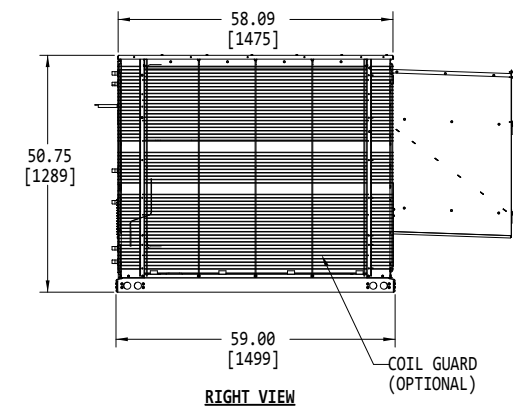
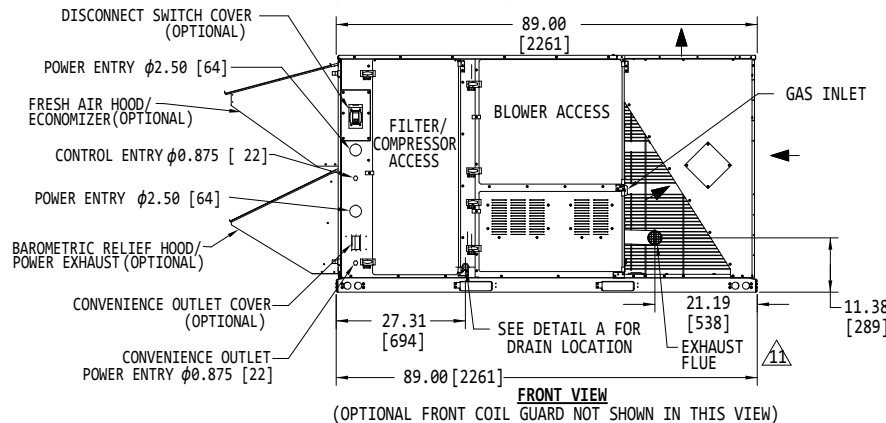
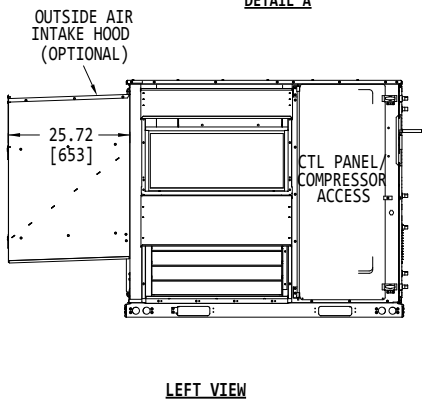
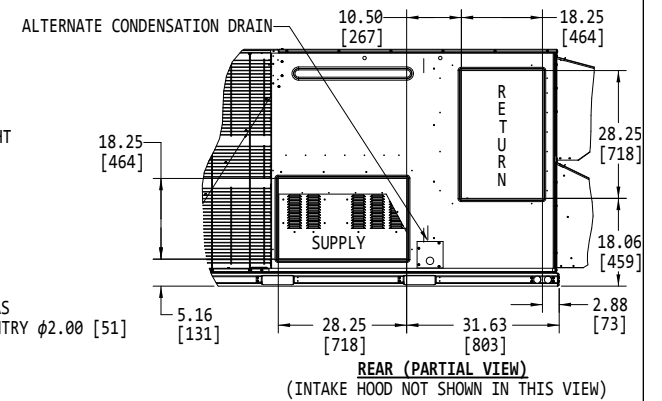
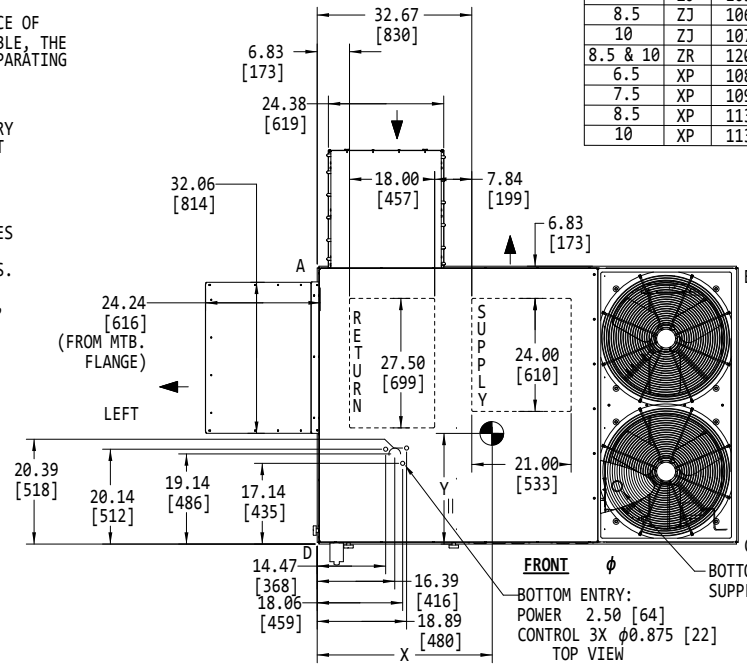
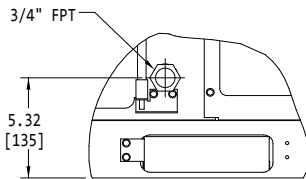
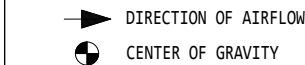

Project Name: **Meridian 10 Ton Pkg Units 575V**
 Quantity: **2**

Unit Model #: **J10ZFE36D5A1BAD1A2**
 System: **J10ZFE36D5A1BAD1A2 (2)**

Seismic Certification

725672-UAD-A-0911



SPECIAL SEISMIC CERTIFICATION
 OF NON-STRUCTURAL
 COMPONENTS AND SYSTEMS



CERTIFICATE OF COMPLIANCE

Dynamic Certification Laboratories has qualified the listed packaged rooftop units as CERTIFIED for seismic applications in accordance with the following codes and standards:

CBC 2010, IBC 2009, ICC-ES AC-156 2010, ASCE 7-05

The following model designations are included in this certification. A complete list of certified models, options, and installation methods are detailed in report number 90300-1107 by Dynamic Certification Laboratories, provided by the equipment manufacturer upon request.

Unitary Product Group Packaged Rooftop Units (UPG)

Seismic Qualification Testing was conducted in accordance with and in strict adherence to the standards set forth within the American Society of Civil Engineers (ASCE 7) by the independent approval agency, Dynamic Certification Laboratories. The above referenced equipment is APPROVED for seismic applications when properly installed and used as intended.

The basis of this certification is through testing of the active and energized components per AC156. This certification covers multiple UPG brands, including York, Johnson Controls, Coleman, Luxaire, Evcon, Fraser-Johnston and Ready Ship.

The seismic values are obtained from the Maximum Considered Earthquake Short Period Spectral Response Acceleration, S_{ds}, as determined by the ASCE 7 seismic maps. Various installation locations/isolation configurations are covered under this certification, limited by the S_{ds} value stated in the following table. A seismic importance factor, I_p, of 1.5 applies to this certification to include essential facility requirements and life safety applications for post event functionality. The units are approved for both a 14" rigid and 22" spring isolated, seismically approved roof curbs, or slab (on grade) mount.

Maximum Design S _{ds} Values of UPG Packaged Rooftop Units				
Series	Model	Tons	S _{ds} (g)	Fp/Wp
ZR/ZJ/ZH/ZK/ZW/ZU/JA3*	037	3	2.5	1.88
ZR/ZJ/ZH/ZK/ZW/ZU/JA4*	049	4	2.5	1.88
ZR/ZJ/ZH/ZK/ZW/ZU/JA5*	061	5	2.5	1.88
ZR/ZJ/ZH/ZF/XP/ZK/ZW/ZU/ZS/XA/J06*	078	6.5	2.5	1.88
ZR/ZJ/ZH/ZF/XP/ZK/ZW/ZU/ZS/XA/J07*/T*	090	7.5	2.5	1.88
ZR/ZJ/ZH/ZF/XP/ZK/ZW/ZU/ZS/XA/J08*	102	8.5	2.5	1.88
ZR/ZJ/ZH/ZF/XP/ZK/ZW/ZU/ZS/XA/J10*/T*	120	10	2.5	1.88
ZR/ZJ/ZH/ZF/XP/ZK/ZW/ZU/ZS/XA/J12*/T*	150	12.5	2.0	1.50

Project Name: **Meridian 10 Ton Pkg Units 575V**

Unit Model #: **J10ZFE36D5A1BAD1A2**

Quantity: **2**

System: **J10ZFE36D5A1BAD1A2 (2)**

Seismic Certification



SPECIAL SEISMIC CERTIFICATION
OF NON-STRUCTURAL
COMPONENTS AND SYSTEMS



CERTIFICATE OF COMPLIANCE

Table of Seismic Design Parameters					
Site Class	F _a	I _p	a _p	R _p	z/h
D	1.0	1.5	2.5	6.0	1.0

Site and Project Requirements

It is the responsibility of the Design Professional of Record to:

- Provide engineering for the anchorage and restraint of the unit
- Validate Certification Design Parameters with actual site conditions
- Provide engineering of all equipment support structures
- Confirm component configuration

Certification Issued by: Dynamic Certification Laboratories

Document Control Number: 90300-1107-A

Issue Date: 9/2/11

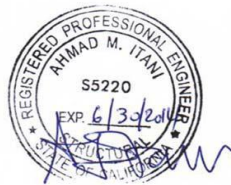

Dr. Ahmad Itani, SE
Dynamic Certification Laboratories



Randy Forristall

Principal Engineer, Commercial Products
YORK Unitary Engineering
Johnson Controls, Incorporated

Project Name: **Meridian 10 Ton Pkg Units 575V**

Unit Model #: **J10ZFE36D5A1BAD1A2**

Quantity: **2**

System: **J10ZFE36D5A1BAD1A2 (2)**

Component Location

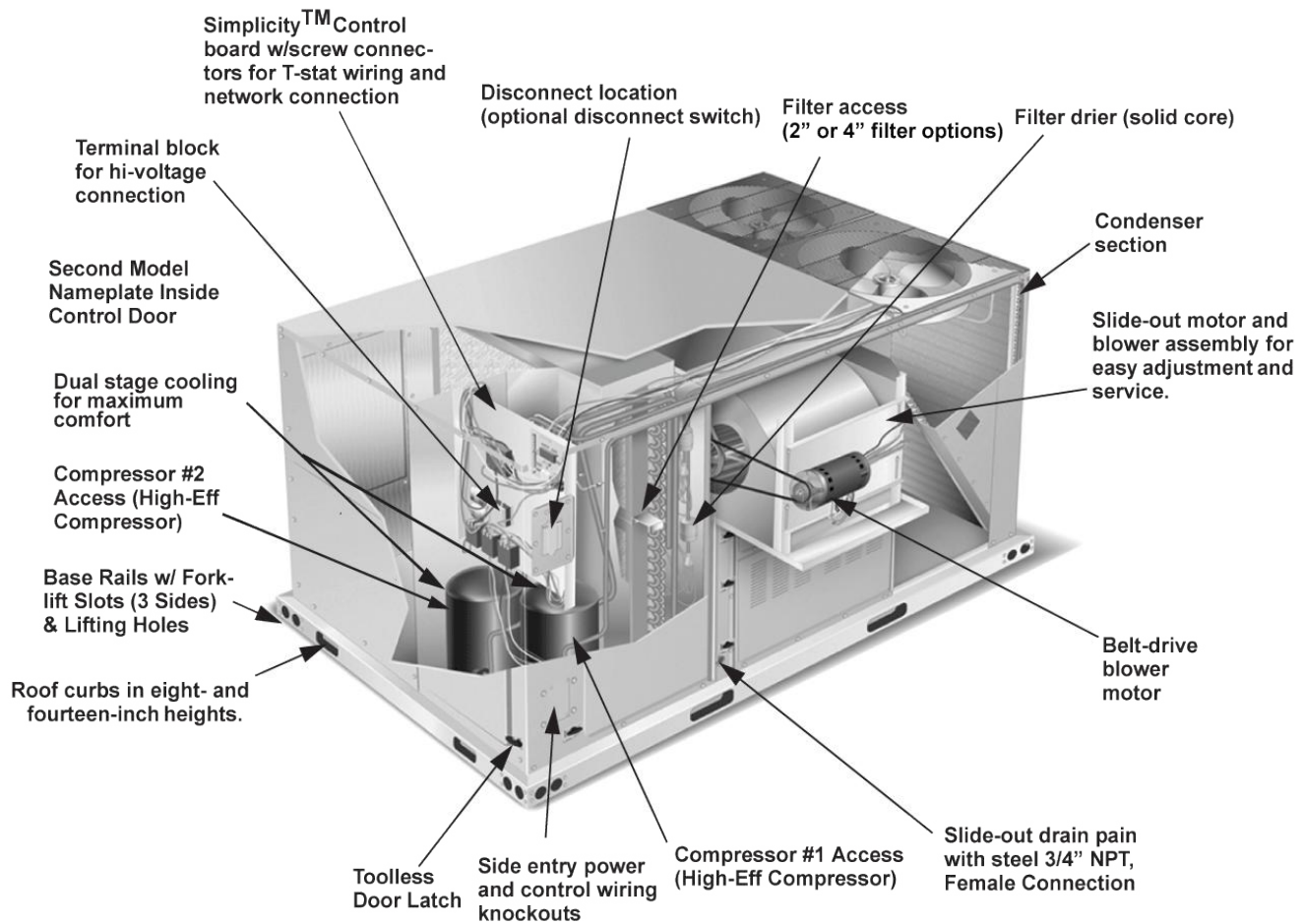

Date

02/03/2016

Project Name

Meridian 10 Ton Pkg Units 575V

Project Number

Client / Purchaser



Guide Specification Summary Page

Product Series	Models and Unit Tags
Series 10 (3-12.5 Ton Package) N524	J10ZFE36D5A1BAD1A2

GENERAL

Units shall be manufactured by Unitary Products in an ISO 9001 certified facility. Johnson Controls Series 10 units are convertible single packages with a common footprint cabinet and common roof curb for all 6-1/2 through 12-1/2 ton models. All units have two compressors with independent R-410A refrigeration circuits to provide 2 stages of cooling. The units were designed for light commercial applications and can be easily installed on a roof curb, slab, or frame. All units are self-contained and assembled on rigid full perimeter base rails allowing for 3-way forklift access and overhead rigging. Every unit is completely charged with R-410A, wired, piped, and tested at the factory to provide a quick and easy field installation. All units are convertible between side and down airflow. Independent economizer designs are used on side and down discharge applications, as well as all tonnage sizes. Units are available in the following configurations: cooling only, cooling with electric heat, cooling with gas heat, reheat only, reheat with electric heat, reheat with gas heat, heat pump and heat pump with electric heat. Electric heaters are available as factory-installed options or field-installed accessories.

DESCRIPTION

Units shall be factory assembled, single package, (Elec/Elec, Gas/ Elec), designed for outdoor installation. They shall have built in field convertible duct connections for down discharge supply/return or horizontal discharge supply/return and be available with factory installed options or field installed accessories. The units shall be factory wired, piped and charged with R-410A refrigerant and factory tested prior to shipment. All unit wiring shall be both numbered and color coded. The cooling performance shall be rated in accordance with DOE and AHRI test procedures. Units shall be CSA certified to ANSI Z21.47 and UL 1995/CAN/CSA No. 236-M90 standards.

UNIT CABINET

Unit cabinet shall be constructed of galvanized steel with exterior surfaces coated with a non-chalking, powder paint finish, certified at 1000 hour salt spray test per ASTM-B117 standards. Indoor blower sections shall be insulated with up to 1" thick insulation coated on the airside. Either aluminum foil faced or elastometric rubber insulation shall be used in the unit's compartments and be fastened to prevent insulation from entering the air stream. Cabinet doors shall be hinged with toolless access for easy servicing and maintenance. Full perimeter base rails shall be provided to assure reliable transit of equipment, overhead rigging, fork truck access and proper sealing on roof curb applications. Disposable 2" filters shall be furnished as standard and be accessible through hinged access door. Fan

performance measuring ports shall be provided on the outside of the cabinet to allow accurate air measurements of evaporator fan performance without removing panels or creating bypass of the coils. Condensate pan shall be slide out design, constructed of a non corrosive material, internally sloped and conforming to ASHRAE 62-B9 standards. Condensate connection shall be a minimum of 3/4" I.D. female and be rigid mount connection.

OUTDOOR (CONDENSER) FAN ASSEMBLY

The outdoor fans shall be of the direct drive type, discharge air vertically, have aluminum blades riveted to corrosion resistant steel spider brackets and shall be dynamically balanced for smooth operation. The outdoor fan motors shall have permanently lubricated bearings internally protected against overload conditions and staged independently. A cleaning window shall be provided on two sides of the units for coil cleaning.

REFRIGERANT COMPONENTS

Compressors:

- Shall be fully hermetic type, direct drive, internally protected with internal high-pressure relief and over temperature protection. The hermetic motor shall be suction gas cooled and have a voltage range of + or - 10% of the unit nameplate voltage.
- Shall have internal spring isolation and sound muffling to minimize vibration and noise, and be externally isolated on a dedicated, independent mounting.

Coils:

- Evaporator coils shall have aluminum plate fins mechanically bonded to seamless internally enhanced copper tubes with all joints brazed. Special Phenolic coating shall be available as a factory option.
- Evaporator coils shall be of the direct expansion, draw-thru design.
- Condenser coils shall have aluminum plate fins mechanically bonded to seamless internally enhanced copper tubes with all joints brazed or Micro-Channel aluminum tube, aluminum fins. Special Phenolic coating shall be available as a factory option.
- Condenser coils shall be of the draw-thru design.

Refrigerant Circuit and Refrigerant Safety Components shall include:

- Independent fixed-orifice or thermally operated expansion devices.

- b. Solid core filter drier/strainer to eliminate any moisture or foreign matter.
- c. Accessible service gage connections on both suction and discharge lines to charge, evacuate, and measure refrigerant pressure during any necessary servicing or troubleshooting, without losing charge.
- d. The unit shall have two independent refrigerant circuits, equally split in 50% capacity increments.

Unit Controls:

- a. Unit shall be complete with self-contained low-voltage control circuit protected by a resettable circuit breaker on the 24-volt transformer side.
- b. Unit shall incorporate a lockout circuit which provides reset capability at the space thermostat or base unit should any of the following standard safety devices trip and shut off compressor:
 - Loss-of-charge/Low-pressure switch.
 - High-pressure switch.
 - Freeze condition sensor on evaporator coil. If any of these safety devices trip, the LCD screen will display the alarm message.
- c. Unit shall incorporate "AUTO RESET" compressor over temperature, over current protection.
- d. Unit shall operate with conventional thermostat designs and have a low voltage terminal strip for easy hook-up.
- e. Unit control board shall have on-board diagnostics and fault message display.
- f. Standard controls shall include anti-short cycle and low voltage protection, and permit cooling operation down to a selectable value as low as 0 °F.
- g. Control board shall monitor each refrigerant safety switch independently.

ELECTRIC HEATING SECTION

An electric heating section, with nickel chromium elements, shall be provided in a range of 9 thru 54KW. The heating section shall have a primary limit control(s) (automatic reset) to prevent the heating element system from operating at an excessive temperature. The Heating Section assembly shall slide out of the unit for easy maintenance and service. Units with Electric Heating Sections shall be wired for a single point power supply with branch circuit fusing (where required).

UNIT OPERATING CHARACTERISTICS

Unit shall be capable of starting and running at 125 °F outdoor temperature, exceeding maximum load criteria of AHRI Standard 340/360. The compressor, with standard controls, shall be capable of operation down to 0 °F outdoor temperature.

ELECTRICAL REQUIREMENTS - All unit power wiring shall enter unit cabinet at a single factory provided location and be capable of side or bottom entry to minimize roof penetrations and avoid unit field modifications. Separate side and bottom openings shall be provided for the control wiring.

STANDARD LIMITED WARRANTIES - Compressor – 5 Years, Heat Exchanger – 10 Years, Stainless Steel Heat Exchanger – 15 Years, Elect. Heat Elem. – 5 Years, Parts – 1 Year.

FACTORY INSTALLED OPTIONAL OUTDOOR AIR
(Shall be made available by either/or):

ADDITIONAL FACTORY INSTALLED OPTIONS

- **Alternate Indoor Blower Motor** – For applications with high restrictions, units are available with optional indoor blower motors that provide higher static output and/or higher airflow.
- **Electric Heat** – Electric Heaters range from 9 thru 54KW and are available in all the voltage options of the base unit.
- **BAS Controls** – Include supply air sensor, return air sensor, dirty filter indicator and air proving switch.

FIELD INSTALLED OPTIONS

- **Coil Guard** - Field installed decorative wire coil guard.



CUSTOM AIR PRODUCTS & SERVICES, INC.
35 Southbelt Industrial Drive • Houston, Texas 77047
(713) 460-9009 • Fax (713) 460-9499
www.customairproducts.com

SECTION

03

ELECTRICAL COMPONENTS



VT7600 Series Programmable & Non-Programmable Thermostats For Commercial HVAC Applications

(Issue Date June 17, 2008 – 028-0132 R8)

Product overview

The VT7600 PI thermostat family is specifically designed for single stage and multi-stage control of heating/cooling equipment such as rooftop and self-contained units. The product features an intuitive, menu-driven, back-lit LCD display which walks users through the programming steps, making the process extremely simple. Accurate temperature control is achieved due to the product's PI time proportional control algorithm, which virtually eliminates temperature offset associated with traditional, differential-based thermostats.

All models contain two digital inputs, which can be set by the user to monitor filter status, activate a remote temporary occupancy switch, and/or used as a general purpose service indicator. In addition, depending on the model, up to three remote sensor inputs are available. All models contain a SPST auxiliary switch, which can be used to control lighting or disable the economizer function and a discharge air sensor input. For more advanced applications, an economizer control logic has been integrated onto the thermostat for use with proportional damper economizer actuators.



Fig.1 - VT7600 Series

The additional following documentation is available on www.viconics.com

- Information on the LON models (VT76xxX1000E), is available on document ITG-VT7600-LON-Exx
- Information on the BACnet models (VT76xxX1000B), is available on document ITG-VT7600-BAC-Exx
- Information on the Wireless models (VT76xx0X1000W), is available on documents: ITG-VWG-40-BAC-Exx and LIT-VWG-40-SETUP-Exx

Models available

Application	1 Heat / 1 Cool	2 Heat / 2 Cool	2 Heat / 2 Cool with economizer	3 Heat / 2 Cool heat pump
Model (programmable)	VT7652A1000	VT7652B1000	VT7656B1000	VT7652H1000
Model (non-programmable)	VT7600A1000	VT7600B1000	VT7605B1000	VT7600H1000

Features and benefits

Features	Benefits
• PI time proportioning algorithm	⇒ Increased comfort , accuracy, and energy savings
• 2 digital inputs	⇒ Adds functionality
• Smart fan	⇒ Saves energy during night mode
• Unique configuration key	⇒ Minimizes parameter tampering
• Lockable keypad	⇒ Tamper proof, no need for thermostat guards
• Freeze protection	⇒ Prevents costly freeze damage
• EEPROM memory	⇒ No loss of program
• 6 hour reserve time for clock	⇒ No need to reprogram day/time after power shortage
• Remote room and outdoor temperature sensor	⇒ Increase flexibility and functionality
• Auxiliary output	⇒ Can be used for lighting and/or economizer override
• Discharge air sensor	⇒ Can be used to monitor unit efficiency
• Intuitive, menu-driven programming (7 day, 2/4 events - on programmable models only)	⇒ Can be used for all types of establishments
• Economizer output (0-10 V d.c.) (on economizer models only)	⇒ Excellent retrofit opportunities
• Low/High balance point (on heat pump models only)	⇒ Protect and optimize systems performances
• 3 Heat/2 Cool (on heat pump models only)	⇒ Support single and two stages heat pump with one auxiliary heat stage

Theory of operation

The VT7600 uses a Viconics proprietary adaptive logic algorithm to control the space temperature. This algorithm controls the heating / air conditioning system to minimize overshoot while still providing comfort. It provides exceptional accuracy due to its unique PI time proportioning control algorithm, which virtually eliminates temperature offset associated with traditional, differential-based on/off thermostats.

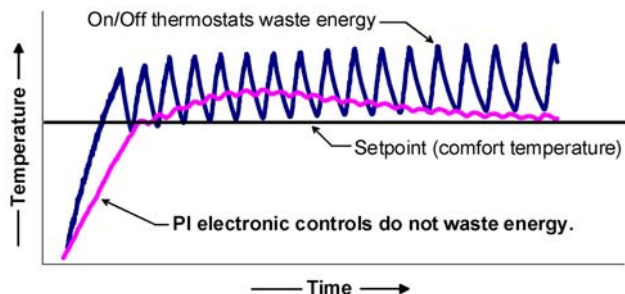

Fig.2 - On/Off mechanical control vs PI electronic control.

Features overview

- 7 day programmable models, 2 or 4 events
- Gas/oil or electric system compatibility for all type of applications
- Remote indoor averaging sensing capability
- Temperature averaging with 2, 3, 4, 9 or 16 sensors
- Remote outdoor sensing capability for added flexibility
 - System mode lock out
 - Heat pump balance point settings
- Remote discharge air sensor input for monitoring purpose
 - System efficiency feedback
- Lockable keypads for tamper proofing. No need for thermostat guards
- Automatic frost protection to prevents costly freeze damage
- Anti short cycle and minimum on/off run time protection. Reduces wear and maximizes life span of mechanical equipment.
- 2 programmable digital inputs for added flexibility. Each input can be programmed as the following:
 - **None:** No function will be associated with the input
 - **Service:** a backlit flashing **Service** alarm will be displayed on the thermostat LCD screen when the input is energized. It can be tied in to the AC unit control card, which provides an alarm in case of malfunction.

- **Filter:** a backlit flashing **Filter** alarm will be displayed on the thermostat LCD screen when the input is energized. It can be tied to a differential pressure switch that monitor filters
- **Rem NSB:** remote NSB timer clock input. Will disable the internal scheduling of the thermostat. The scheduling will now be set as per the digital input. The menu part related to scheduling is disabled and no longer accessible. It provides low cost setback operation via occupancy sensor or from a dry contact
- **RemOVR:** temporary occupancy contact. Disables all override menu function of the thermostat. . The override function is now controlled by a manual remote momentarily closed contact. When configured in this mode, the input operates in a toggle mode.

With this function enabled it is now possible to toggle between unoccupied & occupied setpoints for the amount of time set by parameter (TOccTime) temporary occupancy time.

- Programmable smart fan operation saves energy during night mode
- Non volatile EEPROM memory prevents loss of parameters during power shortage
- Built in default profile set-up for easier start up and commissioning
- Configurable SPST output relay on programmable models for lighting, exhaust fan or fresh air control
- 6 hour typical reserve time for clock in case of power loss
- 0 to 10 Vdc economizer output for more retrofit opportunities
 - Built in dry bulb economizer logic using outdoor temperature sensor
 - Input for supply/mixed air temperature sensor

Heat pump model specific features

- Selectable single or dual stage compressor stages
- High balance point: Locks out auxiliary heating when outside air temperature is above this value
- Low balance point: Locks out heat pump compressor operation when outside air temperature is below this value
- Comfort/economy mode: In economy mode, heat pump use is maximized before turning On auxiliary heating
- Compressor/auxiliary interlock: Adds flexibility by locking out heat pump operation during auxiliary heating to prevent high pressure trip when the coil is downstream of the auxiliary heat source.

Installation

- Remove security screw on the bottom of thermostat cover.
- Open up by pulling on the bottom side of thermostat.
- Remove Assembly and remove wiring terminals from sticker. **(Fig. 3)**
- Please note the FCC ID and IC label installed in the cover upon removal of cover for the wireless products.

A) Location:

- 1- Should not be installed on an outside wall.
- 2- Must be installed away from any heat source.
- 3- Should not be installed near an air discharge grill.
- 4- Should not be affected by direct sun radiation.
- 5- Nothing must restrain vertical air circulation to the thermostat.

B) Installation:

- 1- Swing open the thermostat PCB to the left by pressing the PCB locking tabs. **(Fig. 4)**
- 2- Pull out cables 6" out of the wall.
- 3- Wall surface must be flat and clean.
- 4- Insert cable in the central hole of the base.
- 5- Align the base and mark the location of the two mounting holes on the wall. Install proper side of base up.
- 6- Install anchors in the wall.
- 7- Insert screws in mounting holes on each side of the base. **(Fig. 4)**
- 8- Gently swing back the circuit board on the base and push on it until the tabs lock it.
- 10- Strip each wire 1/4 inch.
- 11- Insert each wire according to wiring diagram.
- 13- Gently push back into hole excess wiring **(Fig. 5)**
- 14- Re-Install wiring terminals in correct location. **(Fig. 5)**
- 15- Reinstall the cover (top side first) and gently push back extra wire length into the hole in the wall.
- 16- Install security screw.

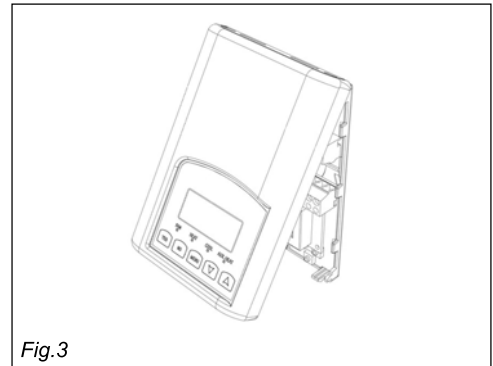

Fig.3

Location of PCB retaining tabs

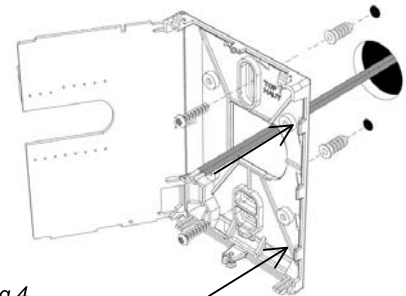

Fig.4

Re-install terminal blocks

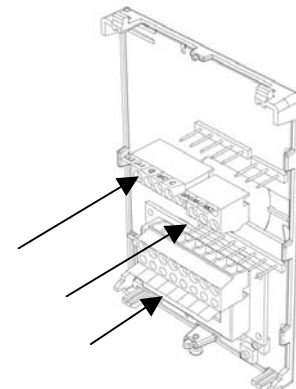

Fig.5

Thermostat assembly (VT7300F 1000 shown)



Fig.6



- If replacing an old thermostat, label the wires before removal of the old thermostat.
- Electronic controls are static sensitive devices. Discharge yourself properly before manipulation and installing the thermostat.
- Short circuit or wrong wiring may permanently damage the thermostat or the equipment.
- Anti-short cycling can be set to 0 minutes for equipment that posses their own anti cycling timer. Do not use that value unless the equipment is equipped with such internal timer. Failure to do so can damage the equipment.
- All VT7600 series thermostats are to be used only as operating controls. Whenever a control failure could lead to personal injury and/or loss of property, it becomes the responsibility of the user to add safety devices and/or alarm system to protect against such catastrophic failures.

Wiring

Terminal identification

Part Number	Multistage				1H / 1C		Part Number	Heat Pump	
	VT7656B	VT7605B	VT7652B	VT7600B	VT7652A	VT7600A		VT7652H	VT7600H
Programmable	Yes	No	Yes	No	Yes	No	Programmable	Yes	No
Top left terminal block							Top left terminal block		
Y2	X	X	X	X			Y2	X	X
Y1	X	X	X	X	X	X	Y1	X	X
G	X	X	X	X	X	X	G	X	X
RC	X	X	X	X	X	X	RC	X	X
C	X	X	X	X	X	X	C	X	X
Top right terminal block							Top right terminal block		
RH	X	X	X	X	X	X	RH	X	X
W1	X	X	X	X	X	X	W1	X	X
W2	X	X	X	X			O/B	X	X
Bottom terminal block							Bottom terminal block		
Econo	X	X							
Aux	X	X	X	X	X	X	Aux	X	X
DI1	X	X	X	X	X	X	DI1	X	X
DI2	X	X	X	X	X	X	DI2	X	X
RS	X	X	X	X	X	X	RS	X	X
Scom	X	X	X	X	X	X	Scom	X	X
OS	X	X	X	X	X	X	OS	X	X
MS	X	X	X	X	X	X	MS	X	X

Screw terminal arrangement

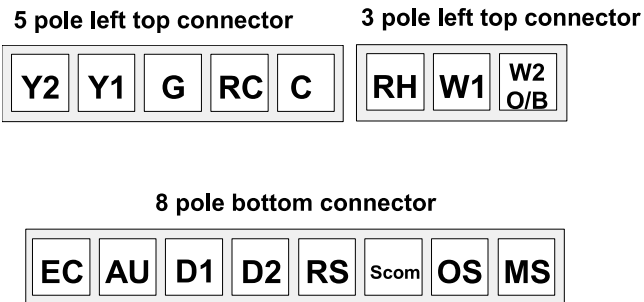

Wiring notes:

- Note 1: If the same power source is used for the heating stages, install jumper across RC & RH. Maximum current is 2.0 amps.
- Note 2: If auxiliary output is used to toggle occupancy of the electronic control card inside the equipment, configure the relay parameter (Aux cont) to the N.O. setting. A second relay can be added for additional functionality of the occupancy output.
- Note 3: Economizer output uses a half bridge rectifier. Reference of the control signal is the common of the power supply of the thermostat. (terminal C)
- Note 4: Electromechanical contacts are to be used with the digital inputs. Electronic triacs cannot be used as mean of switching for the input. The switched leg to the input for the input to activate is terminal C (common)
- Note 5: The transformer of the unit provides power to the thermostat and the additional loads that will be wired to the thermostat.

Detailed wiring diagrams for selected models

VT7656B1000
2 Heat / 2 Cool / Economizer / Programmable

Thermostat Terminals -VT7656B1000

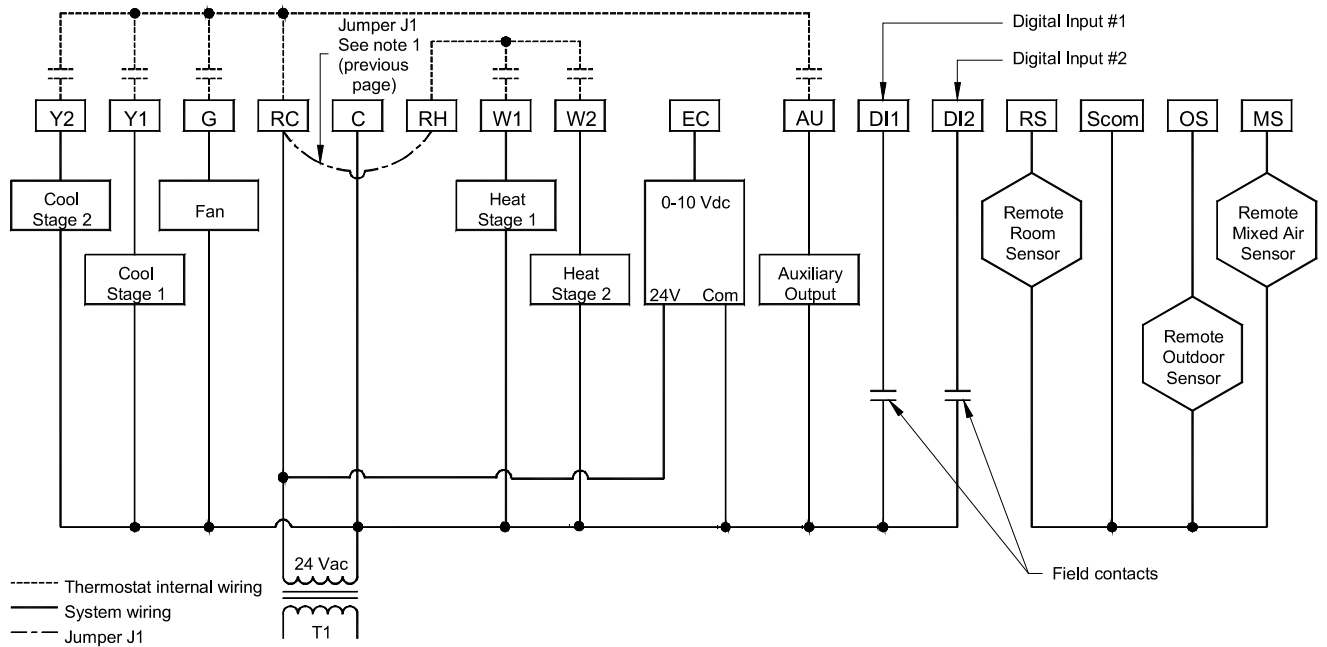
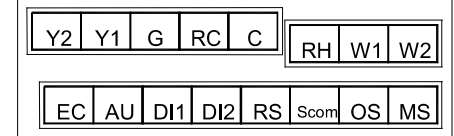

VT7652H1000
Heat pump / Programmable

Thermostat Terminals - VT7652H1000

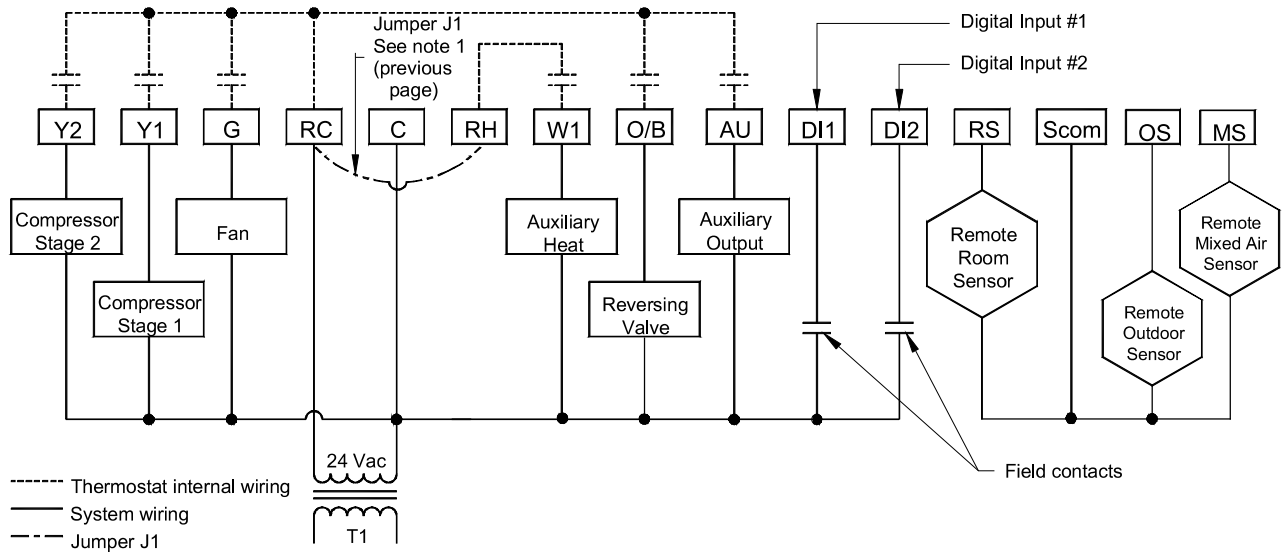
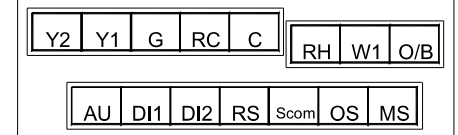

Remote sensor accessories

Model no.	Description
S3010W1000	Wall mounted temperature sensor
S3020W1000	Wall mounted temperature sensor with override button and occupancy status LED
S2020E1000	Outdoor temperature sensor
S2060A1000	Averaging temperature sensor
S2000D1000	Duct mounted temperature sensor



Fig.8 – S3020W1000 wall mounted sensor

Remote mount temperature sensors use 10K NTC thermistors.

- This sensor can be used for:
- 3 thermistors with 2 dip switches are provided with each sensor for various averaging combinations
- Optional occupancy led
- Optional override key

Wiring example of single remote room sensor:

VT7600 Series Thermostat 1x S3020W1000 Remote wiring 1 sensor S2-1 = ON / S2-2 = ON

S3010W1000 Remote wiring 1 sensor S2-1 = ON / S2-2 = ON

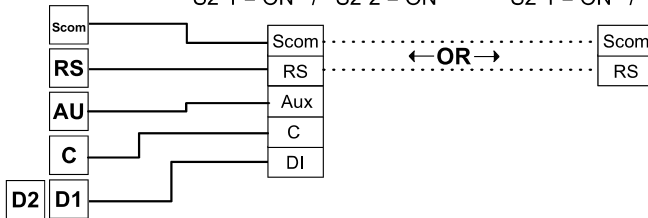

Dip switch setting for: **1 sensor**

ON S2-1 = ON
OFF S2-2 = ON

Wiring examples of 2 remote room sensors for averaging applications:

VT7600 Series Thermostat 2x S3020W1000 Remote wiring 2 sensors S2-1 = OFF / S2-2 = ON

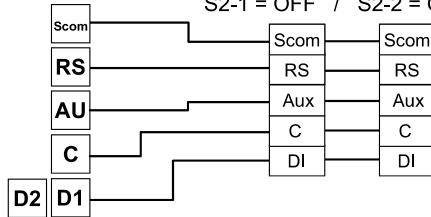

VT7600 Series Thermostat 2x S3010W1000 Remote wiring 2 sensors S2-1 = OFF / S2-2 = ON

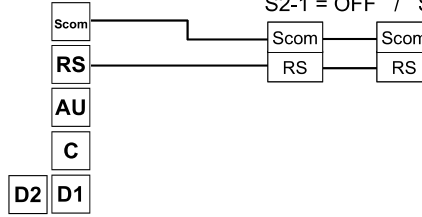

VT7600 Series Thermostat 1x S3010W1000 and 1x S3020W1000 Remote wiring 2 sensors S2-1 = OFF / S2-2 = ON

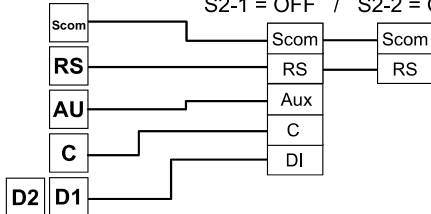

Notes for averaging applications:

- S3010W1000 and S3020W1000 can be mixed matched.
- S3010W1000 and S3020W1000 are to be wired in parallel.
- Respect the dip switch setting in each remote sensor.

Dip switch setting for: **2 sensors**

ON S2-1 = OFF
OFF S2-2 = ON

Wiring examples of 3 remote room sensors for averaging applications:

VT7600 Series Thermostat 2x S3010W1000 and 1x S3020W1000 Remote wiring 3 sensors S2-1 = OFF / S2-2 = OFF

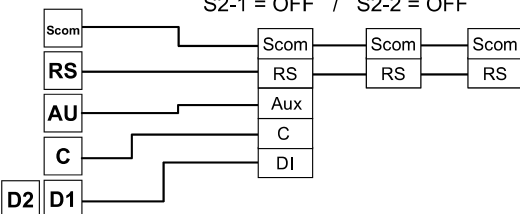

VT7600 Series Thermostat 1x S3010W1000 and 2x S3020W1000 Remote wiring 3 sensors S2-1 = OFF / S2-2 = OFF

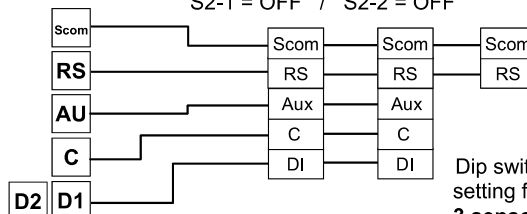

Dip switch setting for: **3 sensors**

ON S2-1 = OFF
OFF S2-2 = OFF

Temperature vs resistance chart for 10 Kohm NTC thermistor

($R_{25^{\circ}\text{C}} = 10\text{K}\Omega \pm 3\%$ - $B_{25/85^{\circ}\text{C}} = 3975\text{K} \pm 1.5\%$)

°C	°F	Kohm	°C	°F	Kohm	°C	°F	Kohm	°C	°F	Kohm	°C	°F	Kohm
-40	-40	324.3197	-20	-4	94.5149	0	32	32.1910	20	68	12.4601	40	104	5.3467
-39	-38	303.6427	-19	-2	89.2521	1	34	30.6120	21	70	11.9177	41	106	5.1373
-38	-36	284.4189	-18	0	84.3147	2	36	29.1197	22	72	11.4018	42	108	4.9373
-37	-35	266.5373	-17	1	79.6808	3	37	27.7088	23	73	10.9112	43	109	4.7460
-36	-33	249.8958	-16	3	75.3299	4	39	26.3744	24	75	10.4443	44	111	4.5631
-35	-31	234.4009	-15	5	71.2430	5	41	25.1119	25	77	10.0000	45	113	4.3881
-34	-29	219.9666	-14	7	67.4028	6	43	23.9172	26	79	9.5754	46	115	4.2208
-33	-27	206.5140	-13	9	63.7928	7	45	22.7861	27	81	9.1711	47	117	4.0607
-32	-26	193.9703	-12	10	60.3980	8	46	21.7151	28	82	8.7860	48	118	3.9074
-31	-24	182.2686	-11	12	57.2044	9	48	20.7004	29	84	8.4190	49	120	3.7607
-30	-22	171.3474	-10	14	54.1988	10	50	19.7390	30	86	8.0694	50	122	3.6202
-29	-20	161.1499	-9	16	51.3692	11	52	18.8277	31	88	7.7360	51	124	3.4857
-28	-18	151.6239	-8	18	48.7042	12	54	17.9636	32	90	7.4182	52	126	3.3568
-27	-17	142.7211	-7	19	46.1933	13	55	17.1440	33	91	7.1150	53	127	3.2333
-26	-15	134.3971	-6	21	43.8268	14	57	16.3665	34	93	6.8259	54	129	3.1150
-25	-13	126.6109	-5	23	41.5956	15	59	15.6286	35	95	6.5499	55	131	3.0016
-24	-11	119.3244	-4	25	39.4921	16	61	14.9280	36	97	6.2866	56	133	2.8928
-23	-9	112.5028	-3	27	37.5056	17	63	14.2629	37	99	6.0351	57	135	2.7886
-22	-8	106.1135	-2	28	35.6316	18	64	13.6310	38	100	5.7950	58	136	2.6886
-21	-6	100.1268	-1	30	33.8622	19	66	13.0307	39	102	5.5657	59	138	2.5926

S3010W1000 remote wall mounted temperature sensor, dip switch location

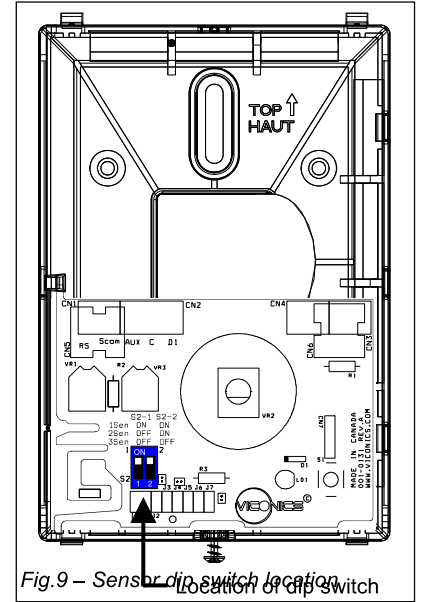

Fig.9 – Sensor dip switch location

S2000D1000, remote duct mounted temperature sensor c/w junction box.

This sensor can be used for:

- Remote return air temperature sensing with the sensor mounted on the return air duct.
- Outside air temperature sensing with the sensor installed in the fresh air plenum.
- Supply air temperature sensor

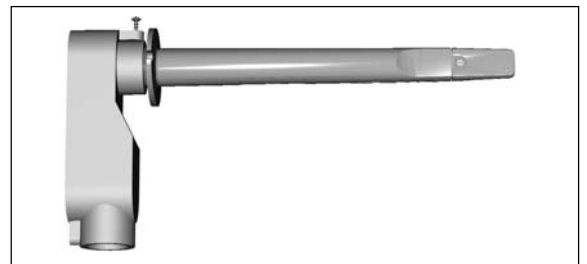

Fig.10 – Remote duct mounted temperature sensor

S2060A1000, remote averaging duct mounted temperature sensor c/w junction box.

This sensor can be used for:

- Remote averaging return air temperature sensing with the sensor mounted on the return air duct.
- Outside air temperature averaging sensing with the sensor installed in the fresh air plenum.
- Mixed air temperature averaging sensor for economizer models with the sensor in the mixing plenum.

S2020E1000, outdoor air temperature sensor

This sensor can be used for:

- Outside air temperature sensing with the sensor installed directly exposed to the elements.
- Sensor uses a water resistant NEMA 4 ABS enclosure for outdoor applications

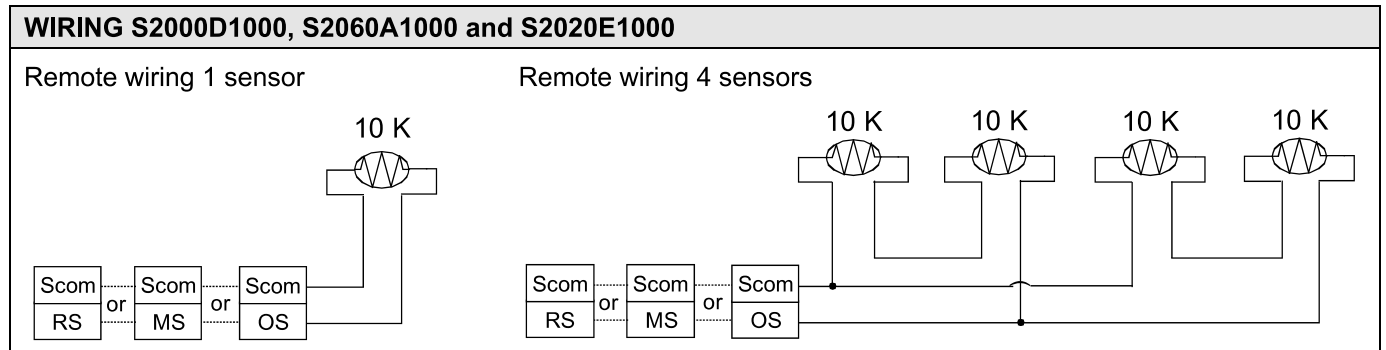

Programming and status display instructions

1. Status display

The thermostat features a two-line, eight-character display. There is a low level back-light level that is always active and can only be seen at night. When left unattended, the thermostat has an auto scrolling display that shows the actual status of the system. Each item is scrolled one by one with the back lighting off. Pressing any key will cause the back light to come on.

Sequence of auto-scroll status display:

Room temperature	Clock status	System mode	Schedule status	Outdoor temperature	Alarms
RoomTemp x.x °C or °F	Monday 12.00 AM	Sys mode auto	Occupied	Outdoor x.x °C or °F	Service
		Sys mode off	Occupied hold		Frost ON
		Sys mode heat	Unoccup		SetClock
		Sys mode cool	Unoccup hold		Filter
		Sys mode emergenc	Override		

Manual scroll of each menu item is achieved by pressing the Yes (scroll) key repetitively. The last item viewed will be shown on the display for 30 seconds before returning to automatic scrolling. Temperature is automatically updated when scrolling is held.

Outdoor air temperature display is only enabled when outdoor air temperature sensor is connected.

- A maximum range status display of 50 °C (122 °F) indicates a shorted sensor. Associated functions, such as mode lockouts and economizer function are automatically disabled.
- A minimum range status -40 °C (-40 °F) is not displayed and indicates a opened sensor or a sensor not connected. Associated functions, such as mode lockouts and economizer function are automatically disabled.

If alarms are detected, they will automatically be displayed at the end of the status display scroll. During an alarm message display, the back lit screen will light up at the same time as the message and shut off during the rest of the status display. Two alarms maximum can appear at any given time. The priority for the alarms is as follows:

Frost ON	Indicates that the heating is energized by the low limit frost protection room temperature setpoint 5,6 °C (42 °F)
SetClock	Indicates that the clock needs to be reset. There has been a power failure which has lasted longer than 6 hours
Service	Indicates that there is a service alarm as per one of the programmable digital input (DI1 or DI2)
Filter	Indicates that the filters are dirty as per one of the programmable digital input (DI1 or DI2)

Three status LEDs on the thermostat cover are used to indicate the status of the fan, a call for heat, or a call for cooling.

Multistage and single stage models

- When the fan is on, the FAN LED will illuminate.
- When heating is on, the HEAT LED will illuminate.
- When cooling is on, the COOL LED will illuminate.

Heat pump models

- When the fan is on, the FAN LED will illuminate.
- When auxiliary heat is on, the AUX HEAT LED will illuminate.
- When compressor is on, the HEAT-PUMP LED will illuminate.

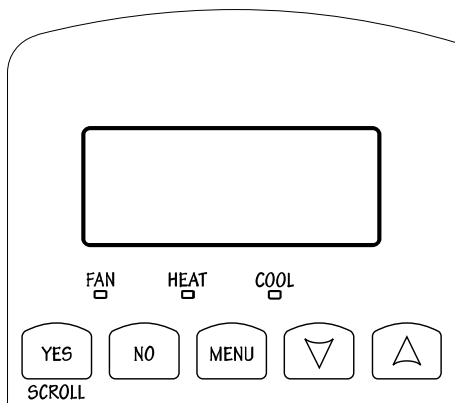

Fig. 11 - Multistage and single stage models

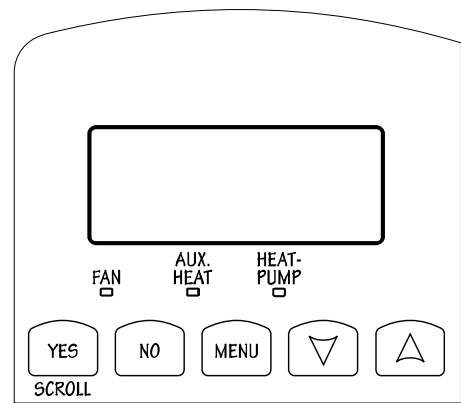

Fig. 12 – Heat pump models

2. User programming instructions menu

The VT7600 series of thermostat feature an intuitive, menu-driven, back-lit LCD display that walks users through the programming steps, making the programming process extremely simple. This menu is typically accessed by the user to set the parameters such as temperature and time events, system mode, fan mode, etc.

It is possible to bring up the user menu at any time by depressing the MENU key. The status display automatically resumes after exiting the user-programming menu.

If the user pauses at any given time during programming, **Auto Help** text is displayed to help and guide the user through the usage and programming of the thermostat.

Ex.: Press yes key to change cooling temperature setpoint
Use the up or down arrow to adjust cooling setpoint

Each of the sections in the menu are accessed and programmed using 5 keys on the thermostat cover.
The priority for the alarms is as follows:



The YES key is used to confirm a selection, to move onto the next menu item and to manually scroll through the displayed information.



The NO key is used when you do not desire a parameter change, and to advance to the next menu item. Can also be used to toggle between heating and cooling setpoints.



The MENU key is used to access the Main User Menu or exit the menu.



The down arrow key is used to decrease temperature setpoint and to adjust the desired values when programming and configuring the thermostat.



The up arrow key is used to increase temperature setpoint and to adjust the desired values when programming and configuring the thermostat.

When left unattended for 45 seconds, the display will resume automatic status display scrolling.

To turn on the back light, press any key on the front panel. The back lit display will turn off when the thermostat is left unattended for 45 seconds

Sequence of user menu:

Override Resume	Temperature setpoints	System mode setting	Fan mode setting	Schedules setting	Clock setting	Schedule hold
Override schd Y/N	Temperat set Y/N	Sys mode set Y/N	Fan mode set Y/N	Schedule set Y/N	Clock set Y/N	Schedule hold Y/N
Appears only in unoccupied mode						Appears only on stand-alone models
Cancel ovrd Y/N						
Appears only in override mode						

There is a default profile set in the thermostat from the factory.

This enables the thermostat to operate as a non-programmable unit in day mode operation at start up.

Programmed default temperature setpoints:	Programmed default modes:
Occupied cooling setpoint = 24 °C (75 °F)	System mode = Auto
Occupied heating setpoint = 22 °C (72 °F)	Fan mode = Smart (for models with a communication module or programmable stand-alone models)
Unoccupied cooling setpoint = 28 °C (82 °F)	Fan mode = Auto (for non-programmable stand-alone models)
Unoccupied heating setpoint = 18 °C (65 °F)	Programmed default schedules:
Fahrenheit scale	Monday through Sunday
Setpoint type = permanent	Occupied time is: 12 00 AM
	Unoccupied time is: 11:59 PM

There will be a 1 minute unoccupied period every night at 11:59 PM with this default configuration.

A) Override an unoccupied period

Override
schd Y/N

This menu will appear only when the thermostat is in unoccupied mode. The unoccupied mode is enabled either by the internal timer scheduling or by a remote NSB contact via DI1 or DI2.

If DI1 or DI2 is configured to operate as a remote temporary override contact, this menu will be disabled.

Answering yes to this prompt will cause the thermostat to go into occupied mode for an amount of time equal to the parameter "TOccTime" (1 to 12 hours).

B) Resume regular scheduling

Cancel
ovrd Y/N

This menu does not appear in regular operation. It will appear only when the thermostat is in Unoccupied override mode.

Answering "Yes" to this question will cause the thermostat to resume the regular programmed setpoints & scheduling.

C) Temperature setpoints

Permanent setpoint changes

Temperat
set Y/N

This menu permits the adjustment of all permanent temperature setpoints (occupied and unoccupied) as well as the desired temperature units (°F or °C). Permanent setpoints are written to RAM and EEPROM

Cooling setpoint Occupied mode		Heating setpoint Occupied mode		Cooling setpoint Unoccupied mode		Heating setpoint Unoccupied mode		°F or °C display setting	
Cooling set? Y/N	No next → Yes down ↓	Heating set? Y/N	No next → Yes down ↓	Unocc CL set? Y/N	No next → Yes down ↓	Unocc HT set? Y/N	No next → Yes down ↓	°F or °C set? Y/N	No next → Yes down ↓
Use ▲ ▼ keys to set value, Yes key to confirm									
Cooling 70.0 °F	Use ▲ ▼ To set value	Heating 68.00 °F	Use ▲ ▼ To set value	Unocc CL 80.0 °F	Use ▲ ▼ To set value	Unocc HT 60.0 °F	Use ▲ ▼ To set value	Units °F	Use ▲ ▼ To set value

Temporary setpoint changes

Temporary setpoints can be modified through the Up arrow key (▲) and the Down arrow keys (▼).

User will be prompted with the present mode (Heating or Cooling) of the thermostat and its setpoint.

The Up (▲) arrow key will increment the setpoint by 0.5 degree (F or C).

The Down (▼) arrow key will decrement the setpoint by 0.5 degree (F or C).

Press the Yes key to accept the new setpoint.

Local changes to the heating or cooling setpoints made by the user directly using the up or down arrow are temporary.

They will remain effective for the duration specified by ToccTime.

Setpoints will revert back to their default value after internal timer ToccTime expires.

If a permanent change to the setpoints is required, use the Temperat set ? menu

D) System mode setting

Sys mode
set Y/N

This menu is accessed to set system mode operation

Use ▲ ▼ to set value, Yes key to confirm

Sys mode auto	Automatic mode Automatic changeover mode between heating and cooling operation
Sys mode cooling	Cooling mode Cooling operation mode only
Sys mode heating	Heating mode Heating operation mode only
Sys mode emergency	Emergency heat mode (heat pump models only) Forced auxiliary heat operation mode only
Sys mode off	Off mode Normal cooling or heating operation disabled If enabled in installer parameters, only the automatic heating frost protection at 50 °F (10 °C) is enabled

E) Fan mode setting

Fan mode set Y/N

This section of the menu is permits the setting of the fan mode operation. Use ▲▼ to set value, Yes key to confirm

Fan mode On	On fan mode Fan is on continuously, even when system mode is OFF.
Fan mode Auto	Automatic fan mode Fan cycles on a call for heating or cooling for both occupied & unoccupied periods.
Fan mode Smart	Smart fan mode During occupied periods, fan is on continuously. In unoccupied mode, fan cycles on a call for heating or cooling. This selection is available on all models with a communication module, on all stand-alone programmable models or if DI1 or DI2 is set to RemNSB on stand-alone non-programmable models

F) Schedule set (2 events)

Scheduling can have 2 or 4 events per day. This is set in the configuration menu as per parameter (2/4event)

Schedule set Y/N

This section of the menu permits the user to set the whether 2 or 4 events is needed. Each day can be tailored to specific schedules if needed.

- 2 events can be programmed per day.
- Occupied & unoccupied periods can be set for each day.

Monday timer Schedule set		Tuesday timer Schedule set		Wednesday timer Schedule set		Other days are identical
Monday set? Y/N	No next → Yes down ↓	Tuesday set? Y/N	No next → Yes down ↓	Wednesda set? Y/N	No next → Yes down ↓	Selects the day to be programmed or modified
Yes key to access day scheduling, No key to jump to next day						
Occupied Day? Y/N	No next → Yes down ↓	Occupied Day? Y/N	No next → Yes down ↓	Occupied Day? Y/N	No next → Yes down ↓	Yes = Daily schedules will be accessed No = Unoccupied mode all day
Yes key to access day scheduling, No key to jump to next day						
		Copy Y/N Previous	Yes next → No down ↓	Copy Y/N Previous	Yes next → No down ↓	Yes = Will copy previous day schedule No = Daily schedules will be accessed
Yes key to copy previous day, No key to set new time value for each day						
Occupied 00:00 AM	Use ▲▼ To set value	Occupied 00:00 AM	Use ▲▼ To set value	Occupied 00:00 AM	Use ▲▼ To set value	Sets Event # 1 Occupied time Will activate occupied setpoints
Use ▲▼ to set value, Yes key to confirm						
Unoccup 00:00 AM	Use ▲▼ To set value	Unoccup 00:00 AM	Use ▲▼ To set value	Unoccup 00:00 AM	Use ▲▼ To set value	Sets Event # 2 Unoccupied time Will activate unoccupied setpoints
Use ▲▼ to set value, Yes key to confirm						

Typical examples of a 2 event office schedule

Ex. #1 Office building closed all weekend

Event	Period #1 - Event #1		Period #1 - Event #2	
	Cool	Heat	Cool	Heat
	Occupied		Unoccupied	
Setpoint	72 °F	70 °F	80 °F	62 °F
Monday	7.00 AM		6.00 PM	
Tuesday	7.00 AM		6.00 PM	
Wednesday	7.00 AM		6.00 PM	
Thursday	7.00 AM		6.00 PM	
Friday	7.00 AM		6.00 PM	
Saturday	12.00 PM *		12.00 PM *	
Sunday	12.00 PM *		12.00 PM *	

Note: 12:00 PM = Noon
12:00 AM = Midnight

Daily Occupancy
Day time only
Day time only
Day time only
Day time only
Day time only
Day time only
Unoccupied
Unoccupied

* Programming consecutive events to the same time will cause the thermostat to choose the last event as the time at which it will set its schedule. In the above example, the thermostat will control to the unoccupied set point until 7:00 AM Monday.

Ex. #2 Commercial building which is occupied all weekend

Event	Period #1 - Event #1		Period #1 - Event #2	
	Cool	Heat	Cool	Heat
	Occupied		Unoccupied	
Setpoint	72 °F	70 °F	80 °F	62 °F
Monday	8.00 AM		5.00 PM	
Tuesday	8.00 AM		5.00 PM	
Wednesday	8.00 AM		5.00 PM	
Thursday	8.00 AM		5.00 PM	
Friday	8.00 AM		5.00 PM	
Saturday	12.00 AM **		11.59 PM **	
Sunday	12.00 AM **		11.59 PM **	

Daily Occupancy
Day time only
Day time only
Day time only
Day time only
Day time only
Day time only
Occupied
Occupied

** To program a day as occupied for 24 hours, set that day Occupied time to 12:00 AM and Unoccupied time to 11:59 PM There will be a 1 minute unoccupied period every night at 11:59 PM with this schedule configuration.

G) Schedule set (4 events)

Schedule set Y/N

This section of the menu permits the user to set the whether 2 or 4 events is needed. Each day can be tailored to specific schedules if needed.

- 4 events can be programmed per day.
- Occupied & Unoccupied periods can be set for each day.
- Programming the 3 rd. & 4 th. events to the same time will cancel the last period.

Monday timer Schedule set		Tuesday timer Schedule set		Wednesday timer Schedule set		Other days are identical
Monday set? Y/N	No next → Yes down ↓	Tuesday set? Y/N	No next → Yes down ↓	Wednesda set? Y/N	No next → Yes down ↓	Selects the day to be programmed or modified
Yes key to access day scheduling, No key to jump to next day						
Occupied Day? Y/N	No next → Yes down ↓	Occupied Day? Y/N	No next → Yes down ↓	Occupied Day? Y/N	No next → Yes down ↓	Yes = Daily schedules will be accessed No = Unoccupied mode all day
Yes key to access day scheduling, No key to jump to next day						
	Copy Y/N Previous	Yes next → No down ↓	Copy Y/N Previous	Yes next → No down ↓	Yes = Will copy previous day schedule No = Daily schedules will be accessed	
Yes key to copy previous day, No key to set new time value for each day						
Occupied 00:00 AM	Use ▲▼ To set value	Occupied 00:00 AM	Use ▲▼ To set value	Occupied 00:00 AM	Use ▲▼ To set value	Sets Event # 1 Occupied time Will activate occupied setpoints
Use ▲▼ to set value, Yes key to confirm						
Unoccup 00:00 AM	Use ▲▼ To set value	Unoccup 00:00 AM	Use ▲▼ To set value	Unoccup 00:00 AM	Use ▲▼ To set value	Sets Event # 2 Unoccupied time Will activate unoccupied setpoints
Use ▲▼ to set value, Yes key to confirm						
Occupie2 00:00 AM	Use ▲▼ To set value	Occupie2 00:00 AM	Use ▲▼ To set value	Occupie2 00:00 AM	Use ▲▼ To set value	Sets Event # 3 Occupied time Will activate occupied setpoints
Use ▲▼ to set value, Yes key to confirm						
Unoccup2 00:00 AM	Use ▲▼ To set value	Unoccup2 00:00 AM	Use ▲▼ To set value	Unoccup2 00:00 AM	Use ▲▼ To set value	Sets Event # 4 Unoccupied time Will activate unoccupied setpoints
Use ▲▼ to set value, Yes key to confirm						

Ex. #1 Four event retail establishment schedule

Event	Period 1 - Event 1		Period 1 - Event 2		Period 2 - Event 3		Period 2 - Event 4		Daily Occupancy
Setpoint	Occupied		Unoccupied		Occupied		Unoccupied		
	Cool 72 °F	Heat 70 °F	Cool 80 °F	Heat 62 °F	Cool 72 °F	Heat 70 °F	Cool 80 °F	Heat 62 °F	
Monday	7.00 AM		5.00 PM		12.00 PM *		12.00 PM *		Day time only
Tuesday	7.00 AM		5.00 PM		12.00 PM *		12.00 PM *		Day time only
Wednesday	7.00 AM		5.00 PM		12.00 PM *		12.00 PM *		Day time only
Thursday	7.00 AM		5.00 PM		7.00 PM		10.30 PM		Day/evening time only
Friday	7.00 AM		5.00 PM		7.00 PM		10.30 PM		Day/evening time only
Saturday	12.00 PM *		12.00 PM *		12.00 PM *		12.00 PM *		Unoccupied
Sunday	12.00 PM *		12.00 PM *		12.00 PM *		12.00 PM *		Unoccupied

* Programming events to the same time will cancel the last period and leave the thermostat in unoccupied mode

Ex. #2 Residential

Event	Period 1 - Event 1		Period 1 - Event 2		Period 2 - Event 3		Period 2 - Event 4		Daily Occupancy
Setpoint	Occupied		Unoccupied		Occupied		Unoccupied		
	Cool 72 °F	Heat 70 °F	Cool 80 °F	Heat 62 °F	Cool 72 °F	Heat 70 °F	Cool 80 °F	Heat 62 °F	
Monday	6:00 AM		8:00 AM		4:00 PM		10:00 PM		Day/evening time only
Tuesday	6:00 AM		8:00 AM		4:00 PM		10:00 PM		Day/evening time only
Wednesday	6:00 AM		8:00 AM		4:00 PM		10:00 PM		Day/evening time only
Thursday	6:00 AM		8:00 AM		4:00 PM		10:00 PM		Day/evening time only
Friday	6:00 AM		8:00 AM		4:00 PM		11:30 PM		Day/evening time only
Saturday	8:00 AM *		8:00 AM *		8:00 AM *		11:59 PM *		Day time only
Sunday	12:00 AM *		12:00 AM *		12:00 AM *		11:59 PM *		Occupied all day

* Programming consecutive events to the same time will cause the thermostat to choose the last event as the time at which it will set its schedule. In the above example for Saturday, the thermostat will control to the occupied set point from 8:00 AM until 11:59 PM. Since it is desired to be in occupied mode throughout the night, then it is necessary to program the first event on Sunday at 12:00 AM. The thermostat will force a one minute unoccupied period for a one minute period (between 11:59 PM and 12:00 AM on Saturday)

H) Clock/Day Settings

Clock set Y/N

This section of the menu permits the user to set the time and day.

Time setting		Day setting		Time format setting	
Time set? Y/N	No next → Yes down ↓	Day set? Y/N	No next → Yes down ↓	12/24hrs set? Y/N	No = exit Yes down ↓
Time 0:00	Use ▲▼ To set value	Day Monday	Use ▲▼ To set value	12/24hrs 12 hrs	Use ▲▼ To set value

J) Schedule hold

Schedule hold Y/N

This menu

- This menu will only appear on stand-alone thermostat, e.i. without a BACnet / Echelon module.
- This section of the menu permits the user to set a permanent schedule hold, which bypasses the internal thermostat scheduling.
- The permanent schedule hold function is typically used for non-scheduled events that extend for various periods of time.
- Enabling a permanent occupied or permanent unoccupied schedule hold will cancel any active override.
- The use of temporary setpoints during permanent hold is permitted. The duration of the temporary setpoint is as set per the TOccTime parameter. Ex. 3 hours

Use ▲▼ to set value, Yes key to confirm

Schedule resume	<p>Resume regular scheduling cancels the permanent hold and re-enables the regular programming as set per internal scheduling or as per remote NSB via one of the DI's configured as remote NSB.</p> <p>This action can also be accomplished by using the Resume menu.</p> <p>Any temporary setpoint that are active will be left active for the duration of the period as set per the TOccTime parameter.</p>
Schedule occ hold	<p>Hold permanent occupied forces the thermostat into a permanent occupied mode using the occupied setpoints. All timed scheduling functions are by-passed.</p> <p>The PERMANENT OCCUPIED status will appear in the automatic status scroll. To resume to regular scheduling, user must scroll to the Schedule Hold menu and select the Schedule resume option..</p>
Schedule uno hold	<p>Hold permanent unoccupied forces the thermostat into a permanent unoccupied mode using the unoccupied setpoints. All timed scheduling functions are by-passed.</p> <p>The PERMANENT UNOCCUPIED status will appear in the automatic status scroll. To resume to regular scheduling, user must scroll to the Schedule Hold menu and select the Schedule resume option..</p>

Installer configuration parameter menu

Configuration can be done through the network or locally at the thermostat.

- To enter configuration, press and hold the middle button (**Menu**) for 8 seconds
- Press the same middle button repetitively to scroll between all the available parameters
- Use the up and down key to change the parameter to the desired value.
- To acknowledge and save the new value, press the middle button again.
- The next listed parameter is now displayed

Configuration parameters	Significance Default value	Adjustments						
DI 1	Digital input no.1 configuration Open contact input = function not energized Closed contact input = function energized Default value = None	None , No function will be associated with the input Rem NSB , remote NSB timer clock input. Will disable the internal scheduling of the thermostat. The scheduling will now be set as per the digital input. The time is still displayed as information, but the menu part related to scheduling is disabled and no longer accessible. Open contact = occupied setpoints Closed contacts = unoccupied setpoints RemOVR Temporary override remote contact. Disables all override menu function of the thermostat. The override function is now controlled by a manual remote momentarily closed contact. When configured in this mode, the input operates in a toggle mode. With this function enabled it is now possible to toggle between unoccupied & occupied setpoints for the amount of time set by parameter (TOccTime) temporary occupancy time. When Override is enabled, an Override status message will be displayed Filter , a back-lit flashing Filter alarm will be displayed on the thermostat LCD screen when the input is energized Service , a back-lit flashing Service alarm will be displayed on the thermostat LCD screen when the input is energized						
DI 2	Digital input no. 2 configuration Default value = None	Same as above. It is possible to configure both inputs to have the same function.						
lockout	Keypad lockout levels Default value = 0 No lock	0 = No lock 1 = Low level 2 = High level						
Level	Resume/Override scheduling	Permanent Occupied and Unoccupied Setpoints	Temporary setpoints using arrows	System mode setting	Fan mode setting	Schedules setting	Clock setting	Permanent hold
	Resume sched Y/N	RoomTemp set Y/N	Up key (▲) Down key (▼)	Sys mode set Y/N	Fan mode set Y/N	Schedule set Y/N	Clock set Y/N	Schedule hold Y/N
0	Yes access	Yes access	Yes access	Yes access	Yes access	Yes access	Yes access	Yes access
1	Yes access	No access	Yes access	No access	No access	No access	Yes access	No access
2	No access	No access	No access	No access	No access	No access	Yes access	No access
pwr del	Power-up delay Default value = 10 seconds	On initial power up of the thermostat (each time 24 Vac power supply is removed & re-applied) there is a delay before any operation is authorized (fan, cooling or heating). This can be used to sequence start up multiple units / thermostat in one location. 10 to 120 seconds						

Frost pr	Frost protection enabled Default value = Off On heat pump models the system mode will be forced to EMERGENCY mode if frost protection is activated	Off: no room frost protection On: room frost protection enabled in all system mode at: 42 °F (5.6 °C) Frost protection is enabled even in system Off mode Off or On
heat max	Maximum heating setpoint limit Default value = 90 °F (32 °C)	Maximum occupied & unoccupied heating setpoint adjustment. Heating setpoint range is: 40 to 90 °F (4.5 to 32.0 °C)
cool min	Minimum cooling setpoint limit Default value = 54 °F (12 °C)	Minimum occupied & unoccupied cooling setpoint adjustment. Cooling setpoint range is: 54 to 100 °F (12.0 to 37.5 °C)
Anticycle	Minimum on/off operation time for stages Default value = 2 minutes Anti-short cycling can be set to 0 minutes for equipment that posses their own anti cycling timer. Do not use that value unless the equipment is equipped with such internal timer. Failure to do so can damage the equipment.	Minimum On/Off operation time of cooling & heating stages. IMPORTANT, anti-short cycling can be set to 0 minutes for equipment that posses their own anti cycling timer. Do <u>not</u> use this value unless the equipment is equipped with such internal timer. Failure to do so can damage the equipment. 0, 1, 2, 3, 4 & 5 minutes
Heat cph	Heating stages cycles per hour Default value = 4 C.P.H. For multi stage models, heat cph applies to W1 & W2 For heat pump models, heat cph applies to W1 only (Emergency heat)	Will set the maximum number of heating stage cycles per hour under normal control operation. It represents the maximum number of cycles that the equipment will turn ON and OFF in one hour. Note that a higher C.P.H will represent a higher accuracy of control at the expense of wearing mechanical components faster. 3, 4, 5, 6,7 & 8 C.P.H.
cool cph	Cooling stages cycles per hour Default value = 4 C.P.H. For multi stage models, cool cph applies to Y1 & Y2 For heat pump models, cool cph applies to Y1 & Y2 in cooling and heating independently of the reversing valve position	Will set the maximum number of cooling stage cycles per hour under normal control operation. It represents the maximum number of cycles that the equipment will turned on and off in one hour. Note that a higher C.P.H will represent a higher accuracy of control at the expense of wearing mechanical components faster. 3 or 4 C.P.H.
Deadband	Minimum deadband Default value = 2.0 °F (1.1 °C)	Minimum deadband value between the heating and cooling setpoints. If modified, it will be applied only when any of the setpoints are modified. 2, 3 or 4 °F (1.0 to 2.0 °C)
fan cont	Fan control Default value = On For multi stage models, fan control applies to W1 & W2 For heat pump models, fan control applies to W1 only (Emergency heat)	Fan control in heating mode. When selecting On ; the thermostat in all cases will always control the fan (terminal G). Valid for On or Auto fan mode When selecting Off ; the fan (terminal G), when heating stages (terminals W1 & W2) are solicited, will not be energized. The fan in this case will be controlled by the equipment fan limit control. Valid only for Auto fan mode. On fan mode will leave the fan always on. On or Off

fan del	Fan delay Default value = Off	Fan delay extends fan operation by 60 seconds after the call for heating or cooling ends. Valid only for Auto fan mode. "On" fan mode will leave the fan always on. Off or On
Com Addr	Thermostat networking address Default value = 4 Range is: 0 to 254 <ul style="list-style-type: none"> • For BACnet MS-TP models valid range to use is from 1 to 127 • For wireless models valid range is 0 to 254 with a maximum of 30 thermostat per VGG 	Conditional parameter to BACnet MS-TP models (VT76xxX1000B) Conditional parameter to Wireless models (VT76xxX1000W) This parameter will only appear when a BACnet or wireless network adapter is present. If the thermostat is installed as a stand-alone unit or with an Echelon adapter, this parameter will not be used or displayed
ToccTime	Temporary occupancy time Default value = 3 hours	Temporary occupancy time with occupied mode setpoints when override function is enabled When the thermostat is in unoccupied mode, function is enabled with either the menu or DI1 or DI2 configured as remote override input. 0,1, 2, 3, 4, 5, 6, 7, 8, 9, 10, 11 & 12 hours
cal RS	Room air temperature sensor calibration Default value = 0.0 °F or °C	Offset that can be added/subtracted to actual displayed room temperature ± 5.0 °F (± 2.5 °C)
cal OS	Outside air temperature sensor calibration Default value = 0.0 °F or °C	Offset that can be added/subtracted to actual displayed outside air temperature ± 5.0 °F (± 2.5 °C)
H stage	Number of heating stages. Applicable to 2 stage models only Default value = 2 stages For heat pump models, H stage is limited to 1 stage only (W1 – Aux. Heat)	Will revert the operation of 2 stages thermostat to single stage operation only when the second heating step is not needed. 1 or 2 stages
C stage Or HP stage	Number of cooling stages 2 stages model only Default value = 2 stages For heat pump models, HP stage selects the number of compressor stages	Will revert the operation of 2 stage thermostat to single stage operation only when the second cooling step is not needed. 1 or 2 stages
H lock	Outside air temperature heating lockout Default value = 120 °F (49 °C)	Disables heating stage operation based on outdoor air temperature. Function will only be enabled if OS (outside air temperature sensor) is connected. From -15 °F up to 120 °F (-26 °C up to 49 °C)
C lock	Outside air temperature mechanical cooling lockout. Default value = -40 °F (-40 °C)	Disables cooling stage operation based on outdoor air temperature. On economizer model, free cooling will not be disabled by this function. Function will only be enabled if OS (outside air temperature sensor) is connected. From -40 °F up to 95 °F (-40 °C up to 35 °C)

2/4event	Number of events configuration Default value = 2 event	<p>2 events, will set up programming for the following Event 1 is for Occupied setpoints Event 2 is for Unoccupied setpoints 4 events, will set up programming for the following Event 1 is for Occupied setpoints Event 2 is for Unoccupied setpoints Event 3 is for Occupied setpoints Event 4 is for Unoccupied setpoints</p>		
aux cont	Auxiliary contact configuration Default value = N.O. normally open	<p>This contact can be used to energize peripheral devices such as: lighting equipment, exhaust fans, economizers, etc. This contact will operate in parallel with the internal occupied/unoccupied schedule of the thermostat or the remote NSB contact if DI1 or DI2 is used. When the system is in OFF mode, the contact will remain in its unoccupied status independently of the occupied / unoccupied schedule.</p>		
		Configured	Contact occupied status	Contact unoccupied status
		N.O.	Closed	Opened
		N.C.	opened	Closed
Prog rec	Progressive recovery enabled Default value = Off Progressive recovery is automatically disabled if DI 1 and / or DI 2 are configured remote NSB	<p>Off, = no progressive recovery The programmed occupied schedule time is the time at which the system will restart. On, = progressive recovery active. The programmed occupied schedule time is the time at which the desired occupied temperature will be attained. The thermostat will automatically optimize the equipment start time. In any case, the latest a system will restart is 10 minutes prior to the occupied period time.</p>		
Heat Pump models only				
high bp	High balance point Default value = 90 °F (32.0 °C) Function will only be enabled if OS (outside air temperature sensor) is connected.	<p>In <i>Heating or Auto mode</i>, it is the outside air temperature value at which the auxiliary heat will be cut off. Above that value, only the heat pump will be used to maintain the heating setpoint 34 to 90 °F (1.0 to 32.0 °C)</p>		
low bp	Low balance point Default value = -12 °F (-24 °C) Function will only be enabled if OS (outside air temperature sensor) is connected.	<p>In <i>Heating, Cooling or Auto mode</i>, it is the outside air temperature value at which the heat pump operation will be cut off. Below that value, only the auxiliary heat will be used to maintain the heating setpoint -40 to 30 °F (-40 to -1.0 °C)</p>		

Comf/eco	Comfort or economy mode Default value = Comfort	Sets the operation and interaction mode of the heat pump with the auxiliary heat. Comfort mode. In <i>Heating mode</i> . If the heat pump is not able to satisfy the heating setpoint, the auxiliary heat will be energized to satisfy the same heating setpoint. Economy mode. In <i>Heating mode</i> . If the heat pump is not able to satisfy the heating setpoint, the auxiliary heat will be energized to satisfy only when the temperature has dropped 2.0 °F (1.1 °C) below the heating setpoint. Selecting economy mode will add a deadband between the heatpump & auxiliary heat in heating mode. The actual temperature maintained will be lower than the true heating setpoint to maximize the heat pump operation. When the outdoor air temperature drops below the <i>low balance point</i> , the deadband will be eliminated and the auxiliary heat will maintain the true heating setpoint alone. Economy mode. In <i>Emergency mode</i> . If <i>Emergency heat mode</i> is selected, the setpoint maintained, will be the heating setpoint.
re valve	Reversing valve operation O/B Default value = O	Heat pump reversing valve operation O will energize the valve in cooling operation. B will energize the valve in heating operation O or B
comp/aux	Compressor/auxiliary interlock Default value = Off	Sets the operation and interaction mode of the heat pump with the auxiliary heat. Interlock Off. In <i>Heating mode</i> . If the heat pump is not able to satisfy the heating setpoint, the auxiliary heat will be energized at the same time as the heat pump stage. Typically applies when the air handler heat pump coil is installed before the auxiliary heat. (all electric systems) Interlock On. In <i>Heating mode</i> . If the heat pump is not able to satisfy the heating setpoint, the auxiliary heat will be energized and the heat pump will be cut off. Typically applies when the air handler heat pump coil is installed after the auxiliary heat. (add on systems) There is a 2 minute delay to restart the heat pump, when the auxiliary heat is shut down Off or On

Notes for Heat Pump models:

When the outside air sensor is not connected or is shorted, the thermostat bypasses:

- The heating lockout
- The cooling lockout
- The low balance point
- The high balance point

Heat Pump model when set in Emergency mode bypasses heating lockout and permits auxiliary heating whenever a heating demand occurs.

Economizer Model only																										
Chngstpt	Changeover setpoint Default value = 55 °F (13.0 °C)	In <i>Cooling</i> mode. The outside air temperature value at which the cooling will be switched over from mechanical (compressor) to free cooling (economizer) 14 to 70 °F (-10.0 to 21.0 °C)																								
min pos	Minimum position Default value = 0% <table border="1" data-bbox="344 445 787 598"> <thead> <tr> <th>Outside air percentage</th> <th>0%</th> <th>5%</th> <th>10%</th> <th>15%</th> <th>20%</th> <th>25%</th> <th>30%</th> </tr> </thead> <tbody> <tr> <td>Setting for 0-10 Vdc Actuators</td> <td>0%</td> <td>5%</td> <td>10%</td> <td>15%</td> <td>20%</td> <td>25%</td> <td>30%</td> </tr> <tr> <td>Setting for 2-10 Vdc Actuators</td> <td>0 to 20%</td> <td>24%</td> <td>28%</td> <td>32%</td> <td>36%</td> <td>40%</td> <td>44%</td> </tr> </tbody> </table>	Outside air percentage	0%	5%	10%	15%	20%	25%	30%	Setting for 0-10 Vdc Actuators	0%	5%	10%	15%	20%	25%	30%	Setting for 2-10 Vdc Actuators	0 to 20%	24%	28%	32%	36%	40%	44%	Outside air damper minimum position. Will be active only when fan is on (G terminal) and the internal or remote scheduling is in occupied mode. When internal or remote scheduling is in unoccupied mode and/or fan is off, minimum position will be set to 0% 0 to 100 % = 0 to 10 Vdc output range
Outside air percentage	0%	5%	10%	15%	20%	25%	30%																			
Setting for 0-10 Vdc Actuators	0%	5%	10%	15%	20%	25%	30%																			
Setting for 2-10 Vdc Actuators	0 to 20%	24%	28%	32%	36%	40%	44%																			
C mech	Mechanical cooling allowed Default value = Off	In <i>Cooling</i> mode. Allows the operation of the mechanical cooling if the free cooling (economizer) cannot maintain the cooling setpoint. Off Typically applies when the MS (mixed air temperature sensor) is installed after the mechanical cooling refrigeration coils. In this case, mechanical cooling will never operate at the same time as free cooling. On Typically applies when the MS (mixed air temperature sensor) is installed before the mechanical cooling refrigeration coils in the mixing plenum. In this case, mechanical cooling is allowed when the free cooling (economizer operation) cannot maintain the cooling setpoint. Off or On																								
mix stpt	Mixed air setpoint Default value = 55 °F (13.0 °C)	Free cooling mixed air setpoint when economizer mode is enabled. 50 to 90 °F (10.0 to 32.0 °C)																								
MS dis	Display mixed air temperature Economizer model only, only if sensor is installed	Used as diagnostic / service help to troubleshoot and diagnose economizer operation.																								

Wireless Model only		
PAN ID	Personal Area Network Identification Default value = 0 Range is: 0 to 500	<p>Conditional parameter to Wireless models (VT76xxX1000W)</p> <p>This parameter will only appear when a wireless network adapter is present. If the thermostat is installed as a stand-alone unit or with a BACnet or Echelon adapter, this parameter will not be used or displayed</p> <p>This parameter (Personal Area Network Identification) is used to link specific thermostats to a single specific Viconics wireless gateway (VWG) For every thermostat reporting to a gateway (maximum of 30 thermostats per gateway), be sure you set the SAME PAN ID value both at the gateway and the thermostat(s).</p> <p>The default value of 0 is NOT a valid PAN ID. The valid range of available PAN ID is from 1 to 500</p>
Channel	Channel selection Default value = 10 Range is: 10 to 26	<p>Conditional parameter to Wireless models (VT76xxX1000W)</p> <p>This parameter will only appear when a wireless network adapter is present. If the thermostat is installed as a stand-alone unit or with a BACnet or Echelon adapter, this parameter will not be used or displayed</p> <p>This parameter (Channel) is used to link specific thermostats to specific Viconics wireless gateway(s) (VWG) For every thermostat reporting to a gateway (maximum of 30 thermostats per gateway), be sure you set the SAME channel value both at the gateway and the thermostat(s).</p> <p><i>Viconics recommends using only the 2 last channels (25-2575MHz and 26-2580MHz)</i></p> <p>The default value of 10 is NOT a valid channel. The valid range of available channel is from 11 to 26</p>
Get From	Thermostat Get From another device configuration utility Default value = 0 Range is: 0 to 254	<p>Conditional parameter to Wireless models (VT76xxX1000W)</p> <p>This parameter / function is not currently supported by the wireless thermostats.</p>

Troubleshooting guide

All models

Symptom	Possible Cause	Corrective Action
No display on the thermostat	Absent or incorrect supply voltage	1. Check power supply voltage between C & RC to be from 19-30 Vac 2. Check for tripped fuse or circuit breaker
	Overloaded power transformer	Verify that the transformer used is powerful enough (enough VA's) to supply all controlled devices including the thermostat
Keyboard menu does not access all functions	Keyboard locked	Change configuration parameter LOCKOUT to value "0" to access all levels of the menu
Temperature setpoints revert to original value after a certain time period	Temporary setpoint option selected	1. The thermostat needs to be in Permanent setpoint mode for the new setpoint to be kept and memory and used all the time 2. Go to the Set temperature menu. 3. The last prompt is setpoint type. Set it to Permanent setpoint
Thermostat will not call for heating	Wrong mode selected	Select heating mode
	Thermostat in Unoccupied mode	Select Occupied Hold in Schedule hold or Override to force the thermostat Occupied heating setpoint
	Anticycle delay active	Wait, the anticycling period will end and the equipment will start
	Heating setpoint is satisfied	Raise the Heating setpoint
	Heating lockout attained	1. Mode is locked out based on outside air temperature 2. Change configuration parameter H Lock to value 120 °F (49 °C) to by-pass lockout
	Wiring error	1. Start the Fan by forcing the Fan ON mode 2. Put a jumper across terminals RH & W1. The heating should come ON. If it does not, verify wiring and check if a jumper is required between RC & RH
Thermostat will not call for cooling	Wrong mode selected	Select cooling mode
	Thermostat in Unoccupied mode	Select Occupied Hold in Schedule hold or Override to force the thermostat Occupied cooling setpoint
	Anticycle delay active	Wait, the anticycling period will end and the equipment will start
	Cooling setpoint is satisfied	Lower the cooling setpoint
	Cooling lockout attained	1. Mode is locked out based on outside air temperature 2. Change configuration parameter C Lock to value - 40 °F (-40 °C) to by-pass lockout
	Wiring error	1. Start the Fan by forcing the Fan ON mode 2. Put a jumper across terminals RC & Y1. The cooling should come ON. If it does not, verify wiring
The thermostat will not turn on the fan	Wrong mode selected	1. Start the Fan by forcing the Fan ON mode 2. Put a jumper across terminals RC & G. The fan should come ON. If it does not, verify wiring
	Wiring error	
Digital display shows missing digits or erratic segments	Defective display	Replace thermostat

Troubleshooting guide

Heatpump models

Auxiliary heat does not operate	Wrong mode selected	Select emergency heat mode
	Thermostat in Unoccupied mode	Select Occupied Hold in Schedule hold or Override to force the thermostat Occupied heating setpoint
	Anticycle delay active	Wait, the anticycling period will end and the equipment will start
	Heating setpoint is satisfied	Raise the Heating setpoint
	High Balance point attained	1.Mode is locked out based on outside air temperature 2.Change configuration parameter High BP to value 90 °F (32 °C) to by-pass lockout
	Heating lockout attained	1.Mode is locked out based on outside air temperature 2.Change configuration parameter H Lock to value 120 °F (49 °C) to by-pass lockout
	Wiring error	1. Start the Fan by forcing the Fan ON mode 2. Put a jumper across terminals RH & W1. The heating should come ON. If it does not, verify wiring and check if a jumper is required between RC & RH
Heat pump does not operate in heating mode	Wrong mode selected	Select heating mode
	Thermostat in Unoccupied mode	Select Occupied Hold in Schedule hold or Override to force the thermostat Occupied heating setpoint
	Anticycle delay active	Wait, the anticycling period will end and the equipment will start
	Heating setpoint is satisfied	Raise the Heating setpoint
	Low Balance point attained	1.Mode is locked out based on outside air temperature 2.Change configuration parameter Low BP to value - 12 °F (-24 °C) to by-pass lockout
	Heating lockout attained	1.Mode is locked out based on outside air temperature 2.Change configuration parameter H Lock to value 120 °F (49 °C) to by-pass lockout
	Wiring error	1. Start the Fan by forcing the Fan ON mode 2. Put a jumper across terminals RH & W1. The heating should come ON. If it does not, verify wiring and check if a jumper is required between RC & RH
	Wrong reversing valve configuration	1.Wrong selection of parameter Re Valve 2.Select O will energize the valve in cooling operation. Valve is normally heat. 3.Select B will energize the valve in heating operation. Valve is normally cool.

Specifications

Thermostat power requirements:	19-30 Vac 50 or 60 Hz; 2 VA (RC & C) Class 2 RC to RH jumper 2.0 Amps 48 VA maximum
Operating conditions:	0 °C to 50 °C (32 °F to 122 °F) 0% to 95% R.H. non-condensing
Storage conditions:	-30 °C to 50 °C (-22 °F to 122 °F) 0% to 95% R.H. non-condensing
Sensor:	Local 10 K NTC thermistor
Resolution:	± 0.1 °C (± 0.2 °F)
Control accuracy:	± 0.5 °C (± 0.9 °F) @ 21 °C (70 °F) typical calibrated
Occupied and unoccupied setpoint range cooling:	12.0 to 37.5 °C (54 to 100 °F)
Occupied and unoccupied setpoint range heating:	4.5 °C to 32 °C (40 °F to 90 °F)
Room and outdoor air temperature range	-40 °C to 50 °C (-40 °F to 122 °F)
Proportional band for room temperature control:	Both outputs: 1.1°C (2.0°F)
Digital inputs:	Relay dry contact only across C terminal to DI1 or DI2
Contact output rating:	Each relay output: (Y1, Y2, G, W1, W2 & AU) 30 Vac, 1 Amp. maximum 30 Vac, 3 Amp. in-rush
Economizer analog output rating:	0 to 10 Vdc into 2KΩ resistance min.
Economizer analog output accuracy:	± 3% typical
Wire gauge	18 gauge maximum, 22 gauge recommended
Dimensions:	4.94" x 3.38" x 1.13"
Approximate shipping weight:	0.75 lb (0.34 kg)
Agency Approvals all models:	UL: UL 873 (US) and CSA C22.2 No. 24 (Canada), File E27734 with CCN XAPX (US) and XAPX7 (Canada) Industry Canada: ICES-003 (Canada) FCC: Compliant to CFR 47, Part 15, Subpart B, Class A (US) CE: EMC Directive 89/336/EEC (Europe Union) C-Tick: AS/NZS CISPR 22 Compliant (Australia / New Zealand) Supplier Code Number N10696 FCC: Compliant to: Part 15, Subpart C
Agency Approvals Stand-Alone, BACnet & LON models	
Agency Approvals Wireless models	

THIS DEVICE COMPLIES WITH PART 15 OF THE FCC RULES. OPERATION IS SUBJECT TO THE FOLLOWING TWO CONDITIONS: (1) THIS DEVICE MAY NOT CAUSE HARMFUL INTERFERENCE, AND (2) THIS DEVICE MUST ACCEPT ANY INTERFERENCE RECEIVED, INCLUDING INTERFERENCE THAT MAY CAUSE UNDESIRE OPERATION.

Drawing & dimensions

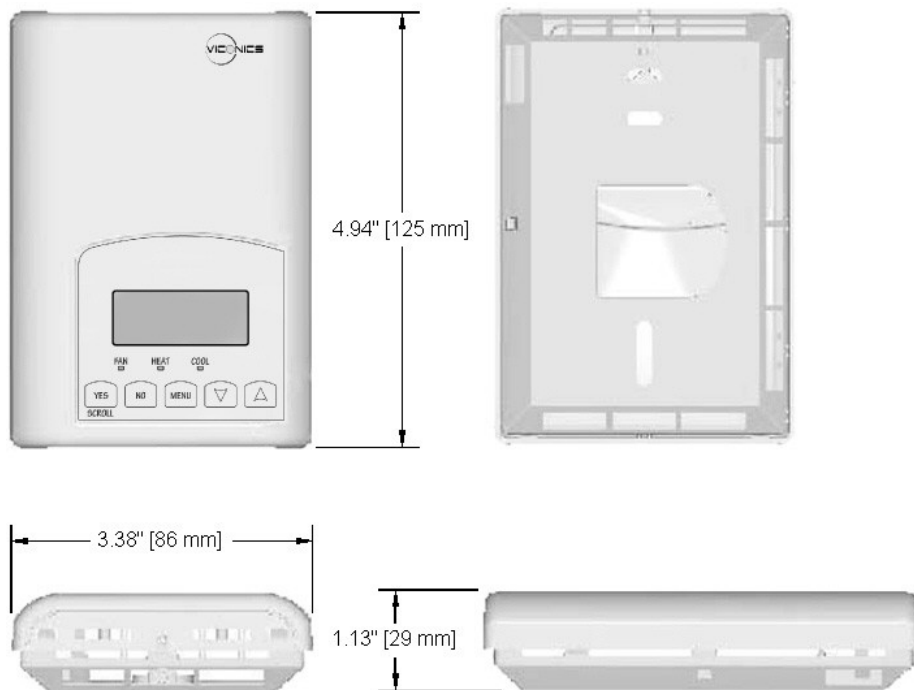

Fig.13 – Thermostat dimensions

Important notice



All VT7600 series controls are for use as operating controls only and are not safety devices. These instruments have undergone rigorous tests and verifications prior to shipment to ensure proper and reliable operation in the field. Whenever a control failure could lead to personal injury and/or loss of property, it becomes the responsibility of the user / installer / electrical system designer to incorporate safety devices (such as relays, flow switch, thermal protections, etc...) and/or alarm system to protect the entire system against such catastrophic failures. Tampering of the devices or miss application of the device will void warranty.

T600MSx-4 and T600MSx-4+PIR Series Multi-Stage Thermostat Controllers

Installation Instructions

T600MSN-4, T600MSP-4,
T600MSN-4+PIR, T600MSP-4+PIR

Part No. 24-9890-935, Rev. —
Issued September 17, 2009

Applications

The T600MSN-4 and T600MSN-4+PIR non-programmable and T600MSP-4 and T600MSP-4+PIR programmable thermostat controllers are specifically designed for control of multi-stage commercial heating and cooling equipment.

IMPORTANT: The T600MSx-4 and T600MSx-4+PIR Series Thermostat Controllers are intended to provide an input to equipment under normal operating conditions. Where failure or malfunction of the thermostat controller could lead to personal injury or property damage to the controlled equipment or other property, additional precautions must be designed into the control system. Incorporate and maintain other devices, such as supervisory or alarm systems or safety or limit controls, intended to warn of or protect against failure or malfunction of the thermostat controller.

North American Emissions Compliance

United States

This equipment has been tested and found to comply with the limits for a Class A digital device pursuant to Part 15 of the FCC Rules. These limits are designed to provide reasonable protection against harmful interference when this equipment is operated in a commercial environment. This equipment generates, uses, and can radiate radio frequency energy and, if not installed and used in accordance with the instruction manual, may cause harmful interference to radio communications. Operation of this equipment in a residential area is likely to cause harmful interference, in which case the user will be required to correct the interference at his/her own expense.

Canada

This Class (A) digital apparatus meets all the requirements of the Canadian Interference-Causing Equipment Regulations.

Cet appareil numérique de la Classe (A) respecte toutes les exigences du Règlement sur le matériel brouilleur du Canada.

Installation

Location Considerations

Locate the T600MSx-4 or T600MSx-4+PIR Series Thermostat Controller:

- on a partitioning wall, approximately 5 ft (1.5 m) above the floor in a location of average temperature
- away from direct sunlight, radiant heat, outside walls, outside doors, air discharge grills, or stairwells; or from behind doors
- away from steam or water pipes, warm air stacks, unconditioned areas (not heated or cooled), or sources of electrical interference

For integrated Passive Infrared (PIR) models, be sure that the thermostat controller is located centrally, where occupant movement is abundant.

Note: Allow for vertical air circulation to the thermostat controller.

To install the thermostat controller:

1. Use a Phillips-head screwdriver to remove the security screw if it is installed on the bottom of the thermostat controller cover.

Note: Normally, the security screw comes packaged separately in a plastic bag with the thermostat controller. Skip this step if the screw is not installed on the bottom of the cover.

2. Pull the bottom edge of the thermostat controller cover and open the thermostat controller as illustrated in Figure 1.

Note: PIR models have a wiring connection between the cover and the Printed Circuit Board (PCB). This connection allows for proper wiring of the occupancy sensor. Carefully remove the wiring connection from the PCB by pulling up on the connector block. Do not attempt to remove the connector block by pulling on the wires.

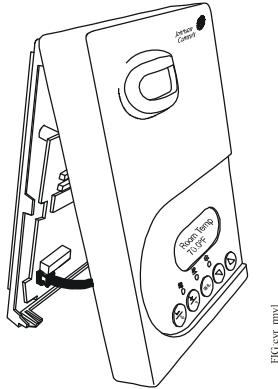

Figure 1: Removing the Thermostat Controller Cover (T600MSx-4+PIR Model Shown)

- Carefully pull the locking tabs on the right side of the thermostat controller mounting base and unlock the PCB. Open the PCB to the left as illustrated in Figure 2.

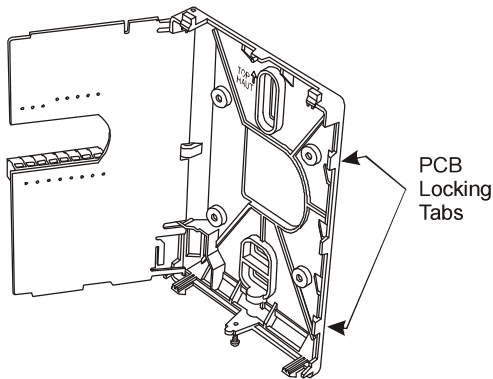

Figure 2: Opening the Thermostat Controller PCB

- Pull approximately 6 in. (152 mm) of wire from the wall and insert the wire through the hole in the thermostat controller mounting base.
- Align the thermostat controller mounting base on the wall and use the base as a template to mark the two mounting hole locations.

Note: Be sure to position the thermostat controller mounting base so that the arrow on the base points upward to indicate the top of the thermostat controller.

- Drill a 3/16 in. (5 mm) hole at each of the two marked locations and tap nylon anchors (included with the thermostat controller) flush to the wall surface.

Note: Other means of anchoring the device may be desired, depending on the wall medium.

- Position the thermostat controller mounting base on the wall and use the two mounting screws (included with the thermostat controller) to secure the base to the wall surface as illustrated in Figure 3.

Note: Be careful not to overtighten the mounting screws.

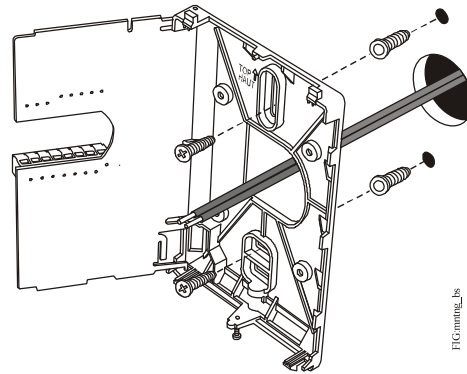

Figure 3: Securing the Thermostat Controller Mounting Base to the Wall

- Swing the PCB back to the right and carefully snap it into the locking tabs on the thermostat controller mounting base.
- Remove the screw terminal blocks that are attached to a disposable adhesive. Figure 4 illustrates the locations of the screw terminal blocks on the thermostat controller.

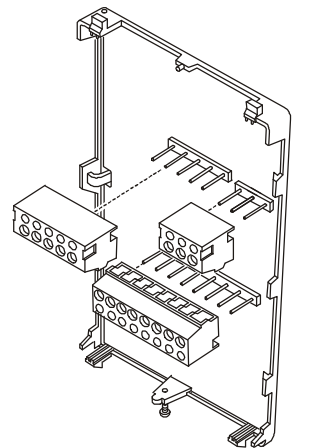

Figure 4: Removing the Screw Terminal Blocks

Wiring

When an existing thermostat controller is replaced, remove and label the wires to identify the terminal functions. When a T600MSx-4 or T600MSx-4+PIR Series Thermostat Controller is replaced, simply remove the old screw terminal blocks and reinsert them onto the PCB of the replacement thermostat controller.

CAUTION: Risk of Electric Shock.
Disconnect power supply before making electrical connections to avoid electric shock.

CAUTION: Risk of Property Damage.
Do not apply power to the system before checking all wiring connections. Short circuited or improperly connected wires may result in permanent damage to the equipment.

IMPORTANT: Make all wiring connections in accordance with local, national, and regional regulations. Do not exceed the electrical ratings of the T600MSx-4 or T600MSx-4+PIR Series Thermostat Controller.

To wire the thermostat controller:

- Strip the ends of each wire a 1/4 in. (6 mm) and connect them to the appropriate screw terminals as indicated in Figure 5.

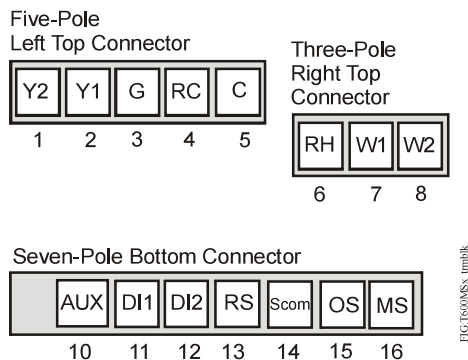

Figure 5: Terminal Blocks

- Carefully push any excess wire back into the wall.

Note: Seal the hole in the wall with fireproof material to prevent drafts from affecting the ambient temperature readings.

- Reinsert the screw terminal blocks onto the PCB.

Note: If multiple wires are inserted into the terminals, be sure to properly twist the wires together prior to inserting them into the terminal connectors.

- For PIR models, carefully reattach the PIR connector to the PCB.
- Reattach the thermostat controller cover to the mounting base (top side first).
- Use a Phillips-head screwdriver to install the security screw on the bottom of the thermostat controller cover if desired. The security screw comes packaged separately in a plastic bag with the thermostat controller.

Table 1: Terminal Identification (See Figure 5.)

Terminal Number	Terminal Label	Function
1	Y2 ¹	Energizes on a Call for Second-Stage Cooling
2	Y1 ¹	Energizes on a Call for First-Stage Cooling
3	G ¹	Energizes Fan in Accordance with Selected Fan Mode
4	RC	24 VAC from Equipment Transformer
5	C	24 VAC (Common) from Equipment Transformer
6	RH	24 VAC for Heating Stage
7	W1 ²	Energizes on a Call for First-Stage Heating
8	W2 ²	Energizes on a Call for Second-Stage Heating
10	AUX ¹	Auxiliary Output
11	DI1	Configurable Digital Input 1
12	DI2	Configurable Digital Input 2
13	RS	Remote Room Temperature Sensor
14	Scom	Sensor Common
15	OS	Outside Air Temperature Sensor
16	MS	Not Used

- This terminal provides the voltage from RC through a relay contact.
- This terminal provides the voltage from RH through a relay contact.

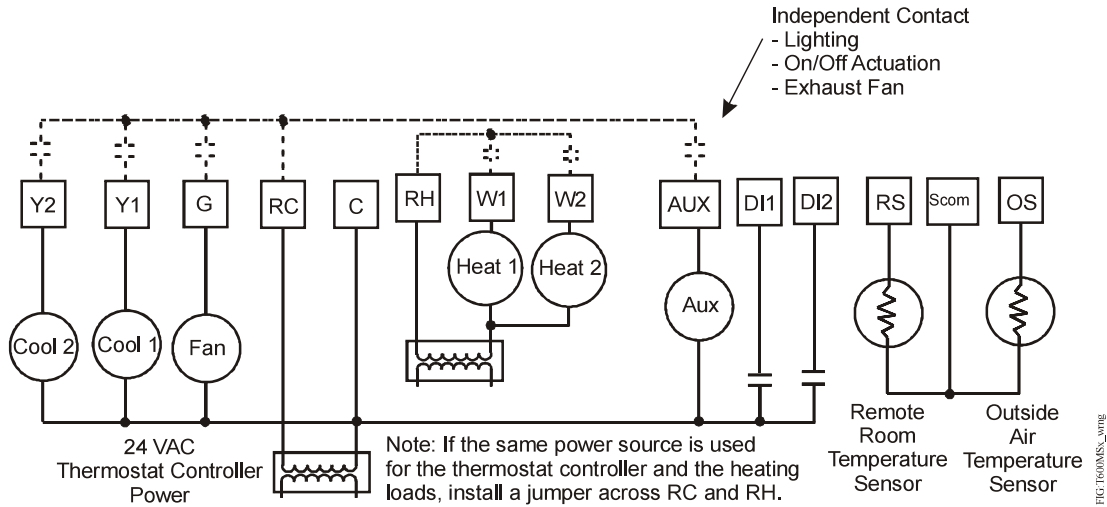

Figure 6: Wiring the T600MSx-4 or T600MSx-4+PIR Series Thermostat Controller

Setup and Adjustments

Thermostat Controller Operation Overview

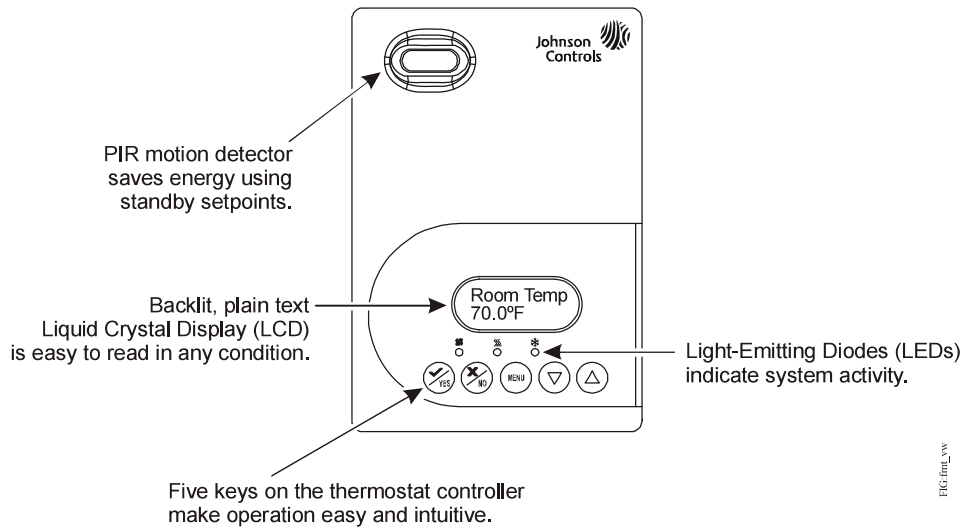

Figure 7: Front Cover of Thermostat Controller (T600MSx-4+PIR Model Shown)

Thermostat Controller User Interface Keys

The T600MSx-4 and T600MSx-4+PIR Series Thermostat Controller user interface consists of five keys on the front cover (as illustrated in Figure 7). The function of each key is as follows:

- Use the **YES** key to:
 - confirm menu selections and to advance to the next menu item.

- stop the Status Display Menu from scrolling and to manually scroll to the next parameter on the menu.

Note: When the thermostat controller is left unattended for 45 seconds, the thermostat controller display resumes scrolling.

- Use the **NO** key to decline a parameter change and to advance to the next menu item.



- Use the **MENU** key to:
 - access the Main User Menu or exit the menu
 - access the Installer Configuration Menu or to exit the menu (See *Configuring the T600MSx-4 or T600MSx-4+PIR Series Thermostat Controller* on page 6.)
- Use the **UP/DOWN** arrow keys to change the configuration parameters and to activate a setpoint adjustment.

Backlit LCD

The T600MSx-4 and T600MSx-4+PIR Series Thermostat Controllers include a 2-line, 8-character backlit display. Low-level backlighting is present during normal operation, and it brightens when any user interface key is pressed. The backlight returns to low level when the thermostat controller is left unattended for 45 seconds.

LEDs

Three LEDs are included to indicate the fan status, call for heat, or call for cooling:

- The fan LED  is on when the fan is on.
- The heat LED  is on when heating is on.
- The cool LED  is on when cooling is on.

Integrated PIR Sensor – T600MSx-4+PIR Series Thermostat Controllers

The integrated PIR sensor allows for automatic switching between fully adjustable Occupied and Unoccupied temperature setpoints without user interaction. This feature generates incremental energy savings during scheduled occupied periods while the space is unoccupied.

Programming Overview

Three menus are used to view, program, and configure the T600MSx-4 and T600MSx-4+PIR Series Thermostat Controllers: the Status Display Menu, the Main User Menu, and the Installer Configuration Menu.

Status Display Menu

The Status Display Menu is displayed during normal thermostat controller operation, and continuously scrolls through the following parameters:

- Room Temperature
- Day and Time (T600MSP-4 and T600MSP-4+PIR Models)

- System Mode
- Schedule Status (Occupied/Unoccupied/Override [PIR Models])
- Outside Temperature – An outside air temperature sensor must be installed and connected.
- Applicable Alarms – The backlight lights up as an alarm condition is displayed.

Note: Press the **YES** key to temporarily stop this menu from scrolling.

Note: An option is available within the Installer Configuration Menu to lock out the scrolling display and show only the Room Temperature parameter.

Main User Menu

Use the Main User Menu to access and change the basic operating parameters of the thermostat controller. Access the menu by pressing the **MENU** key during normal thermostat controller operation.

Installer Configuration Menu

Use the Installer Configuration Menu to set up the thermostat controller for application-specific operation. To access the menu, press and hold the **MENU** key for approximately 8 seconds.

Occupancy Sensor Operation – T600MSx-4+PIR Series Thermostat Controllers

A T600MSx-4+PIR Series Thermostat Controller (or a T600MSx-4 Series Thermostat Controller equipped with a PIR accessory cover) provides advanced occupancy logic.

Note: The PIR strategy is an occupied strategy. If the thermostat controller is programmed to be Unoccupied, the PIR function does not have an affect on the occupancy strategy.

The thermostat controller automatically switches the occupancy level between Occupied and Unoccupied as required, when local movement is sensed. In the Occupied mode, if no movement is detected beyond the **Unocc TM** parameter setting, the mode changes to Unoccupied. Once movement is detected, the mode changes back to Occupied.

Occupancy sensing is enabled only if a PIR cover is installed. The PIR cover, when installed, is auto detected.

PIR Diagnostic LEDs

The diagnostic LEDs inside the PIR lens brighten when movement is detected within the first 30 minutes after powerup. The LEDs do not light up or brighten after the initial 30-minute period.

Setpoints

The installer must be certain that the difference between the Occupied and Unoccupied setpoints can be recovered within a timely fashion to ensure occupancy comfort. In addition, the difference between the two setpoints must be large enough to warrant maximum energy savings.

These setpoints and Unoccupied timers are adjustable to allow for customization, as dictated by the individual space requirements. See Figure 8 for an example of increasing room temperature setpoints.

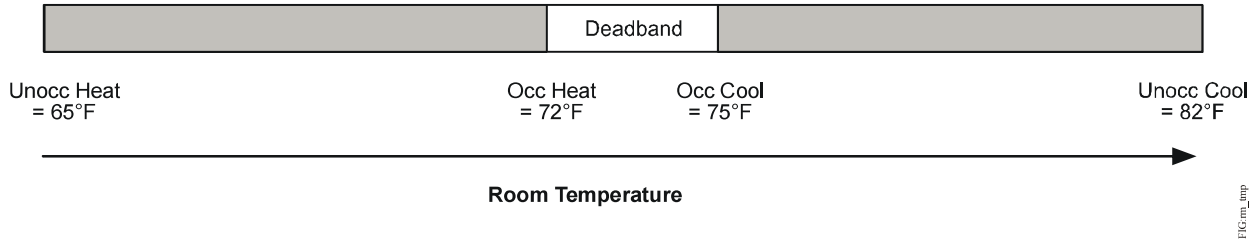

Figure 8: Increasing Room Temperature Setpoints

Configuring the T600MSx-4 or T600MSx-4+PIR Series Thermostat Controller

The T600MSx-4 and T600MSx-4+PIR Series Thermostat Controllers come from the factory with default settings for all configurable parameters. The default settings are shown in Table 2. To reconfigure the parameters via the thermostat controller, follow the steps in this section.

1. To access the Installer Configuration Menu, press and hold the **MENU** key for approximately 8 seconds.

Note: If the **Password** parameter is configured, Password 0 appears on the thermostat controller display indicating that the configured password is required to proceed. Use the **UP/DOWN** arrow keys to indicate the configured password, then press the **YES** key to proceed through the Installer Configuration Menu parameters.

2. Once the Installer Configuration Menu begins, press the **NO** key to scroll through the parameters listed in Table 2.

3. When the desired parameter is displayed, use the **YES** key to choose the desired selection option.
4. Press the **YES** key and then the **NO** key to continue scrolling through the parameters.

To exit the Installer Configuration Menu at any time, press the **MENU** key, then at the exit prompt, press the **YES** key. To pass over a parameter without changing it, press the **NO** key.

When the thermostat controller is in the Installer Configuration Menu and left unattended for approximately 8 seconds, the thermostat controller reverts to the Status Display Menu.

Configuring Inputs DI1 and DI2

When DI1 and DI2 are configured for an alarm condition, an alarm condition is displayed locally when the input is closed. An alarm message is included on the scrolling Status Display Menu and when the message is displayed, the backlight momentarily lights up.

Each input can be configured to the Selection Options included in Table 2.

Table 2: Installer Configuration Menu (Part 1 of 6)

Parameter Appearing on Display	Description and Default	Selection Options
Pswrd	Sets the protective access password to prevent unauthorized access to the Installer Configuration Menu. Default: 0 Note: The default setting does not lock out access to the Installer Configuration Menu.	Range: 0 to 1,000

Table 2: Installer Configuration Menu (Part 2 of 6)

Parameter Appearing on Display	Description and Default	Selection Options
DI1¹	Configuration of Digital Input 1. Default: None	<p>(None): No function is associated with an input.</p> <p>(Service): A Service alarm is displayed on the thermostat controller when the input is energized. Tie this input into the air conditioning unit control card, which provides an alarm if a malfunction occurs.</p> <p>(Filter): A Filter alarm is displayed. This alarm can be connected to a differential pressure switch that monitors a filter.</p> <p>(RemOVR): Temporary occupancy request via a remote input. This override function is controlled by a manual remote occupancy override. When enabled, this condition disables the override capability of the thermostat controller.</p> <p>(RemNSB): Remote Night Setback (NSB) via a time clock input, an occupancy sensor, or from a voltage-free contact. Contact open = Occupied; contact closed = Unoccupied.</p> <p>(Fan lock): A backlit flashing Fan lock alarm is displayed on the thermostat controller when the input is not energized. This alarm is used in conjunction with a local airflow sensor connected to the input. The thermostat controller heating or cooling action is locked out if no airflow is detected 10 seconds after the fan (Terminal G) is energized. Contact open = no airflow; contact closed = airflow present.</p>
DI2¹	Configuration of Digital Input 2. Default: None	<p>(None): No function is associated with an input.</p> <p>(Service): A Service alarm is displayed on the thermostat controller when the input is energized. Tie this input into the air conditioning unit control card, which provides an alarm if a malfunction occurs.</p> <p>(Filter): A Filter alarm is displayed. This alarm can be connected to a differential pressure switch that monitors a filter.</p> <p>(RemOVR): Temporary occupancy request via a remote input. This override function is controlled by a manual remote occupancy override. When enabled, this condition disables the override capability of the thermostat controller.</p> <p>(RemNSB): Remote Night Setback (NSB) via a time clock input, an occupancy sensor, or from a voltage-free contact. Contact open = Occupied; contact closed = Unoccupied.</p> <p>(Fan lock): A backlit flashing Fan lock alarm is displayed on the thermostat controller when the input is not energized. This alarm is used in conjunction with a local airflow sensor connected to the input. The thermostat controller heating or cooling action is locked out if no airflow is detected 10 seconds after the fan (Terminal G) is energized. Contact open = no airflow; contact closed = airflow present.</p>
MenuScro	Gives the option of having the display continuously scroll the parameters. Default: on	<p>(off): The scroll is inactive.</p> <p>(on): The scroll is active.</p>

Table 2: Installer Configuration Menu (Part 3 of 6)

Parameter Appearing on Display	Description and Default	Selection Options			
Lockout	Selectable Lockout Levels for limiting end-user keypad interaction. Default: 0	Function	Lockout Level		
			(0)	(1)	(2)
		Occupancy Override	Access	Access	No Access
		Permanent Temperature Setpoints	Access	No Access	No Access
		Temporary Temperature Setpoints	Access	Access	No Access
		System Mode Setting	Access	No Access	No Access
		Fan Mode Setting	Access	No Access	No Access
		Schedules Setting²	Access	No Access	No Access
		Clock Setting²	Access	Access	Access
Permanent Hold²	Access	No Access	No Access		
Pwr del³	Sets the delay time period at thermostat controller powerup, or each time power is removed and reapplied, before any operation (fan, heating, or cooling) is authorized. Also can be used to sequence the startup of multiple units in one location. Default: 10.0 sec	Range: 10.0 to 120.0 sec			
Frost pr	Provides a minimum heating setpoint of 42.0°F/5.5°C to prevent freezing in the zone controlled by the thermostat controller. Default: off	(on): Enabled (off): Disabled			
Heat max⁴	Sets the Occupied and Unoccupied maximum Heating setpoint values. Default: 90.0°F/32.0°C	Range: 40.0°F/4.5°C to 90.0°F/32.0°C			
Cool min⁴	Sets the Occupied and Unoccupied minimum Cooling setpoint values. Default: 54.0°F/12.2°C	Range: 54.0°F/12.2°C to 100.0°F/37.7°C			

Table 2: Installer Configuration Menu (Part 4 of 6)

Parameter Appearing on Display	Description and Default	Selection Options
Pband	<p>Sets the proportional band used by the thermostat controller Proportional-Integral (PI) control loop. Default: 2.0F°/1.1C° Note: The proportional band default setting of 2.0F°/1.1C° provides satisfactory thermostat controller operation in most instances. A proportional band setting other than the default is normally used in installations where the location of the thermostat controller is problematic, leading to unwanted cycling. An example of a problematic installation is a wall-mounted thermostat controller installed between the return and supply air feeds, that is directly influenced by the supply air stream.</p>	<p>(2): 2.0F°/1.1C° (3): 3.0F°/1.7C° (4): 4.0F°/2.2C° (5): 5.0F°/2.8C° (6): 6.0F°/3.3C° (7): 7.0F°/3.9C° (8): 8.0F°/4.4C°</p>
Anticycl	<p>Anti-Short Cycle timer sets the minimum on/off times for heating and cooling. Default: 2.0 min Note: Set the anti-short cycle timer to 0.0 min for equipment that already has its own anti-short cycle timer.</p>	<p>Range: 0.0 to 5.0 min adjustable in 1-minute increments</p>
Heat cph	<p>Sets the maximum number of Heating cycles per hour. Default: 4.0</p>	<p>Range: 3.0 to 8.0 cycles per hour</p>
Cool cph	<p>Sets the maximum number of Cooling cycles per hour. Default: 4.0</p>	<p>Range: 3.0 or 4.0 cycles per hour</p>
Deadband	<p>Sets the minimum deadband between the heating and cooling setpoints. Default: 2.0F°/1.0C°</p>	<p>Range: 2.0F°/1.0C° to 4.0F°/2.0C° adjustable in 1.0F°/0.5C° increments</p>
Fan cont	<p>Determines how the fan is activated in response to a call for heating. Default: on Note: The Fan cont parameter applies to W1 and W2 when the fan is in the Auto mode only. The Fan cont parameter does not affect fan operation on a call for cooling (Y1 and Y2).</p>	<p>(off): The thermostat controller does not activate the fan in response to a call for heating. The fan is activated by the equipment fan and limit control. (on): Enables the thermostat controller to activate the fan in response to a call for heating.</p>
Fan del	<p>Fan delay extends fan operation after a heating or cooling cycle has ended. Default off Note: The fan delay is only active when the fan is in the Auto mode.</p>	<p>(on): Extends fan operation by 60 seconds after a heating or cooling cycle has ended. (off): No extension of fan operation after a heating or cooling cycle has ended.</p>

Table 2: Installer Configuration Menu (Part 5 of 6)

Parameter Appearing on Display	Description and Default	Selection Options
TOccTime	<p>Sets the duration of the Temporary Occupancy Time (when the thermostat controller is in the Unoccupied mode) when a Schedule Override Function is enabled using either the Main User Menu or DI1 or DI2 configured as a temporary override remote contact (RemOVR).</p> <p>Sets the effective duration of the Temporary heating or cooling setpoints set using the UP/DOWN arrow keys.</p> <p>Default: 3.0 hrs</p>	Range: 0.0 to 12.0 hrs adjustable in 1-hour increments
Cal RS	<p>Sets the desired room air temperature sensor calibration (offset). The offset can be added to or subtracted from the actual displayed room temperature.</p> <p>Default: 0.0F°/0.0C°</p>	Range: -5.0F°/-2.5C° to 5.0F°/2.5C° adjustable in 1.0F°/0.5C° increments
Cal OS	<p>Sets the desired outside air temperature sensor calibration (offset). The offset can be added to or subtracted from the actual displayed room temperature.</p> <p>Default: 0.0F°/0.0C°</p>	Range: -5.0F°/-2.5C° to 5.0F°/2.5C° adjustable in 1.0F°/0.5C° increments
H stage	<p>Reverts the operation of a two-stage thermostat controller to a single-stage thermostat controller when the second heating stage is not needed.</p> <p>Default: 2.0</p>	(1.0): One Stage (2.0): Two Stages
C stage	<p>Reverts the operation of a two-stage thermostat controller to a single-stage thermostat controller when the second cooling stage is not needed.</p> <p>Default: 2.0</p>	(1.0): One Stage (2.0): Two Stages
H lock	<p>Disables heating stage(s) operation when the outside air temperature is greater than the configured value. If the fan mode is set to Auto or Smart, the fan output is also disabled. Requires that an outside air temperature sensor be installed and connected.</p> <p>Default: 120°F/49°C</p>	Range: -15°F/-26°C to 120°F/49°C adjustable in 5F°/5C° increments
C lock	<p>Disables cooling stage(s) operation when the outside air temperature is less than the configured value. If the fan mode is set to Auto or Smart, the fan output is also disabled. Requires that an outside air temperature sensor be installed and connected.</p> <p>Default: -40°F/-40°C</p>	Range: -40°F/-40°C to 95°F/35°C adjustable in 5F°/5C° increments

Table 2: Installer Configuration Menu (Part 6 of 6)

Parameter Appearing on Display	Description and Default	Selection Options
Unocc TM	Sets the time delay between the moment when the thermostat controller toggles from the Occupied mode to the Unoccupied mode after the last motion is detected by the occupancy sensor. Default: 0.5 hours	Range: 0.5 hours to 24.0 hours adjustable in 0.5 hour increments
2/4event²	Sets the number of events within a 24-hour period. Default: 2.0	(4.0): Four events (two Occupied and two Unoccupied) within a 24-hour period (2.0): Two events (one Occupied and one Unoccupied) within a 24-hour period
Aux cont	Energizes peripheral devices (lighting equipment, exhaust fans, and economizers). Default: n.o. Note: The contact toggles with the internal Occupied/Unoccupied schedule (or the NSB contact on one of the digital inputs, if used).	(n.c.): Contact open = Occupied; contact closed = Unoccupied (n.o.): Contact closed = Occupied; contact open = Unoccupied
Prog rec²	Provides the desired occupied temperature either at the start of the Occupied schedule or after the Occupied schedule begins. Default: off Note: Progressive recovery is disabled if either DI1 or DI2 is configured as remote NSB.	(on): Enabled (provides the desired occupied temperature at the start of the Occupied schedule) (off): Disabled (provides the desired occupied temperature after the Occupied schedule begins)

1. Setting DI1 or DI2 to RemNSB disables schedules and stops the Schedule menu display. Any other setting enables schedules and the Schedule menu (T600MSP-4 and T600MSP-4+PIR models).
2. T600MSP-4 and T600MSP-4+PIR models.
3. When adjusting the numeric value, press the **UP/DOWN** arrow key to change the value by single increments; press and hold the **UP/DOWN** arrow key to change the numeric value in increments of ten.
4. When adjusting the temperature, press the **UP/DOWN** arrow key to change the value in 0.5F°/0.5C° increments; press and hold the **UP/DOWN** arrow key to change the value in 5.0F°/5.0C° increments.

Operation

Setup/Operation of the T600MSx-4 or T600MSx-4+PIR Series Thermostat Controller

Once the thermostat controller is configured via the Installer Configuration Menu, set up its operating parameters via the Main User Menu. Access this menu by pressing the **MENU** key during normal thermostat controller operation. The Main User Menu contains the basic operating features of the thermostat controller.

The Main User Menu also uses Auto Help, which is displayed automatically in the menu when there is a pause in setup activity. To exit Auto Help, continue with the setup selection. When the thermostat controller is in the Main User Menu and is left unattended for 45 seconds, the menu reverts to the Status Display Menu.

Follow the steps in Table 3 to set up the thermostat controller.

Table 3: Setting Up the T600MSx-4 or T600MSx-4+PIR Series Thermostat Controller (Part 1 of 2)

Thermostat Controller Display	Description
RoomTemp 75.0 °F	Press the MENU key while in the Status Display Menu to enter the Main User Menu.
Override schd Y/N	Overrides Unoccupied Setpoints Only Appears if Thermostat Controller is in Unoccupied State See <u>Enabling Temporary Override Schedule</u> on page 12.
Cancel ovrd Y/N	Cancels Override Mode
Temperat set? Y/N	Sets the Temperature Setpoints See <u>Entering Permanent Temperature Setpoints</u> on page 13.
Sys mode set? Y/N	Selects the System Mode Default: Automatic (auto) See <u>Selecting the System Mode</u> on page 14.

Table 3: Setting Up the T600MSx-4 or T600MSx-4+PIR Series Thermostat Controller (Part 2 of 2)

Thermostat Controller Display	Description
Fan mode set? Y/N	Selects the Fan Mode Default: Automatic (auto) for T600MSN-4 and T600MSN-4+PIR Models Smart (smart) for T600MSP-4 and T600MSP-4+PIR Models See <u>Selecting the Fan Mode</u> on page 14.
Schedule set? Y/N	Sets the Occupied and Unoccupied Time Periods See <u>Programming the Daily Schedule – Two-Event (T600MSP-4 and T600MSP-4+PIR Models)</u> on page 15 and <u>Programming the Daily Schedule – Four-Event (T600MSP-4 and T600MSP-4+PIR Models)</u> on page 16.
Clock set? Y/N	Sets the Day and Time See <u>Setting the Day and Time (T600MSP-4 and T600MSP-4+PIR Models)</u> on page 17.
Schedule hold? Y/N	Sets a Permanent Hold on the Schedule or Resumes the Schedule See <u>Setting Schedule Hold</u> on page 17.

Note: Schedule Set and Clock Set are available on the T600MSP-4 and T600MSP-4+PIR models only.

Enabling Temporary Override Schedule

Note: The Override Schedule function is available on the T600MSN-4 and T600MSN-4+PIR models only when DI1 or DI2 is configured as remote NSB.

Note: The Override Schedule prompt only appears when in the Unoccupied (Unoccup) or Unoccupied Hold (Unoccup hold) mode.

The override schedule prompt only appears when the thermostat controller is in the Unoccupied state. This menu selection gives the user the option of overriding the Unoccupied setpoints with the Occupied setpoints for the amount of time specified under the **TOccTime** parameter. See Configuring the T600MSx-4 or T600MSx-4+PIR Series Thermostat Controller on page 6.

Note: If DI1 or DI2 is configured to operate as a remote override contact, this menu is disabled.

To override the Unoccupied state while in the Main User Menu:

1. Press the **NO** key for all prompts until the Override Schedule prompt appears. If the thermostat controller is in the Unoccupied state, this is the first prompt.
2. Press the **YES** key to enable the temporary override. The thermostat controller returns to the Status Display Menu.

When scrolling through the Status Display Menu, Override now appears for the schedule status parameter.

Canceling the Temporary Override

The Cancel Override (Cancel ovr) prompt only appears when the thermostat controller is in the Unoccupied override mode.

To resume the schedule while in the Main User Menu:

1. Press the **NO** key for all prompts until the Cancel ovr prompt appears. If the thermostat controller is in the override state, this is the first prompt.
2. Press the **YES** key to resume the programmed schedule.

The thermostat controller returns to the Status Display Menu.

Entering Permanent Temperature Setpoints

The first prompt appearing in the Main User Menu of the thermostat controller when in the Occupied state sets the permanent temperature setpoint.

To enter the permanent heating and cooling setpoints for the Occupied and Unoccupied modes, follow the steps in Table 4. When changing the temperatures, press and release the keys to change the temperature in 0.5F°/0.5C° increments; press and hold down the keys to change the temperature in 5.0F°/5.0C° increments.

Table 4: Entering Permanent Temperature Setpoints (Part 1 of 2)





Thermostat Controller Display	Description
	Press the MENU key while in the Status Display Menu to enter the Main User Menu.
	Press the NO key for all prompts until the temperature setpoint prompt appears on the display (it may be the first prompt). Press the YES key to enter the temperature setting menu.
	Press the YES key to change the Occupied cooling setpoint. Press the NO key to advance to the Occupied heating setpoint menu.
	Press the UP/DOWN arrow keys to set the temperature. Press the YES key to store the value and advance to the next menu.
	Press the YES key to change the Occupied heating setpoint. Press the NO key to advance to the Unoccupied cooling setpoint menu.
	Press the UP/DOWN arrow keys to set the temperature. Press the YES key to store the value and advance to the next menu.
	Press the YES key to change the Unoccupied cooling setpoint. Press the NO key to advance to the Unoccupied heating setpoint.
	Press the UP/DOWN arrow keys to set the temperature. Press the YES key to store the value and advance to the next menu.

Table 4: Entering Permanent Temperature Setpoints (Part 2 of 2)

Thermostat Controller Display	Description
Unocc HT set? Y/N	Press the YES key to change the Unoccupied heating setpoint. Press the NO key to advance to the temperature display units.
Unocc HT 62.0°F	Press the UP/DOWN arrow keys to set the temperature. Press the YES key to store the value and advance to the next menu.
°F/°C set? Y/N	Press the YES key to set the display units to °F or °C. Press the NO key to advance to the temperature setpoint type menu.
Exit? Y/N	Press the YES key to return to the Status Display Menu or press the NO key to re-enter the temperature setting menu.

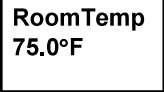
Entering Temporary Temperature Setpoints

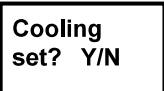
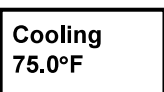
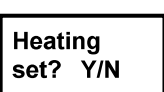
The user can temporarily change the temperature setpoints for the Occupied and Unoccupied heating and cooling modes. To temporarily change the setpoint, press the **UP/DOWN** arrow keys to change the temporary setpoint for the current mode of operation.

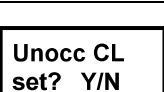
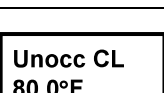
Note: Whether the thermostat controller is heating or cooling, the respective setpoint is temporarily adjusted. To toggle between the temporary heating and cooling setpoints, press the **NO** key while changing the temporary setpoints.

Ending Temporary Temperature Setpoints

The temporary setpoints remain in effect for the duration set in the **TOccTime** parameter or until manually released.

Note: Setting the **TOccTime** parameter to 0.0 hrs prevents the temporary setpoints from taking effect.

To manually release the temporary setpoint, while in the Main User Menu:

1. Press the **NO** key for all prompts until the Temperature set prompt appears. If the thermostat controller is in the Occupied state, this is the first prompt.

2. Press the **YES** key to cancel all temporary setpoints.
3. Press the **MENU** key again and press the **YES** key to exit the Main User Menu.

The setpoint reverts to the Permanent Temperature Setpoint.

Selecting the System Mode

The thermostat controller has four system modes:

- **Automatic Mode (auto):** Automatic changeover between heating and cooling. This is the default setting.
- **Cooling Mode (cool):** Cooling operation only.
- **Heating Mode (heat):** Heating operation only.
- **Off Mode (off):** The thermostat controller is off; however, when the frost protection (**Frost pr** parameter) is enabled, the thermostat controller still calls for heat if the temperature falls below 42°F/5.5°C.

To set the system mode while in the Main User Menu:

1. Press the **NO** key for all prompts until the system mode prompt appears on the display. Press the **YES** key to select the desired system mode.
2. Press the **UP/DOWN** arrow keys to locate the desired system mode. Press the **YES** key to select the desired system mode.
3. Press the **YES** key to return to the Status Display Menu or press the **NO** key to return to the system mode selection menu.

Selecting the Fan Mode

The thermostat controller has three fan mode settings:

- **On Fan Mode (on):** Energizes the fan all the time for both Occupied and Unoccupied states, even if the system mode is set to off.
- **Automatic Fan Mode (auto):** Energizes the fan only on a call for heating or cooling, for both Occupied and Unoccupied states. This is the default setting for the T600MSN-4 and T600MSN-4+PIR models.

Note: The setting for the **Fan cont** parameter may affect the fan operation on a call for heating.

- **Smart Fan Mode (smart):** Energizes the fan all the time for Occupied states, and only on a call for heating or cooling in Unoccupied states. This is the default setting for the T600MSP-4 and T600MSP-4+PIR models.

To select the fan mode while in the Main User Menu:

1. Press the **NO** key for all prompts until the fan mode prompt appears on the display. Press the **YES** key to set the fan mode.
2. Press the **UP/DOWN** arrow keys to locate the desired fan mode. Press the **YES** key to select the desired fan mode.
3. Press the **YES** key to return to the Status Display Menu or press the **NO** key to return to the fan mode selection menu.

Programming the Daily Schedule – Two-Event (T600MSP-4 and T600MSP-4+PIR Models)

The schedule-setting menu is used to enter the Occupied or Unoccupied states for each day of the week. The schedule-setting menu reflects either a two- or a four-event schedule per day, based on what was selected in the **2/4event** parameter during the configuration process. If the schedule-setting menu does not reflect a two-event schedule, select two events in the **2/4event** parameter of the Installer Configuration Menu.

When changing the time, press and release the **UP/DOWN** arrow keys to change the time in 1-minute increments; press and hold down the keys to change the time in 30-minute increments.

Note: Programming one of the digital inputs to remote NSB disables the menu.

To set the time schedule for a two-event schedule, follow the steps in Table 5. See Table 7, Events 1 and 2, for an example of a two-event office schedule.

Table 5: Programming the Daily Schedule – Two-Event (Part 1 of 2)

Thermostat Controller Display	Description
RoomTemp 75.0°F	Press the MENU key while in the Status Display Menu to enter the Main User Menu.
Schedule set? Y/N	Press the NO key for all prompts until the schedule set prompt appears on the display. Press the YES key to enter the scheduling menu.

Table 5: Programming the Daily Schedule – Two-Event (Part 2 of 2)

Thermostat Controller Display	Description
Monday set? Y/N	Press the YES key to set the schedule for Monday or press the NO key to advance to Tuesday.
Occupied day? Y/N	Press the YES key to set the Occupied start time for Monday or press the NO key to advance to Tuesday. Selecting NO leaves the thermostat controller in the Unoccupied state for the entire day.
Occupied 12:00 AM	Press the UP/DOWN arrow keys to set the Occupied start time. Press the YES key to enter the time.
Unoccup 12:00 AM	Press the UP/DOWN arrow keys to set the Unoccupied start time. Press the YES key to enter the time.
Tuesday set? Y/N	Press the YES key to set the schedule for Tuesday or press the NO key to advance to Wednesday.
Copy Y/N previous	Press the YES key to copy the schedule from the previous day. Press the NO key to set a different schedule.
Wednesda set? Y/N	If the YES key was pressed, the next prompt is for Wednesday. Repeat the procedure for the rest of the days of the week.
Exit? Y/N	After setting the schedule for all the days of the week, following the last entry for Sunday, press the YES key to return to the Status Display Menu or press the NO key to start again at Monday.

Programming the Daily Schedule – Four-Event (T600MSP-4 and T600MSP-4+PIR Models)

The schedule-setting menu is used to enter the Occupied and Unoccupied states for each day of the week. The schedule-setting menu reflects either a two- or four-event schedule per day, based on what was selected in the **2/4event** parameter during the configuration process. If the schedule-setting menu does not reflect a four-event schedule, select four events in the **2/4event** parameter of the Installer Configuration Menu.

When changing the time, press and release the **UP/DOWN** arrow keys once to change the time in 1-minute increments; press and hold down the keys to change the time in 30-minute increments.

Note: Programming one of the digital inputs to remote NSB disables the menu.

To set the time schedule for a four-event schedule, follow the steps in Table 6. See Table 7 for an example of a four-event office schedule.

Table 6: Programming the Daily Schedule – Four-Event (Part 1 of 2)

Thermostat Controller Display	Description
RoomTemp 75.0°F	Press the MENU key from the Status Display Menu to enter the Main User Menu.
Schedule set? Y/N	Press the NO key for all prompts until the schedule set prompt appears on the display. Press the YES key to enter the scheduling menu.
Monday set? Y/N	Press the YES key to set the schedule for Monday or press the NO key to advance to Tuesday.
Occupied day? Y/N	Press the YES key to set the Occupied start time for Monday or press the NO key to advance to Tuesday. Selecting NO leaves the thermostat controller in the Unoccupied state for the entire day.
Occupied 12:00 AM	Press the UP/DOWN arrow keys to set the first Occupied start time. Press the YES key to enter the time.

Table 6: Programming the Daily Schedule – Four-Event (Part 2 of 2)

Thermostat Controller Display	Description
Unoccup 12:00 AM	Press the UP/DOWN arrow keys to set the first Unoccupied start time. Press the YES key to enter the time.
Occupie2 12:00 AM	Press the UP/DOWN arrow keys to set the second Occupied start time. Press the YES key to enter the time.
Unoccup2 12:00 AM	Press the UP/DOWN arrow keys to set the second Unoccupied start time. Press the YES key to enter the time.
Tuesday set? Y/N	Press the YES key to set the schedule for Tuesday or press the NO key to advance to Wednesday.
Copy Y/N previous	Press the YES key to copy the schedule from the previous day. Press the NO key to set a different schedule.
Wednesda set? Y/N	If the YES key was pressed, the next prompt is for Wednesday. Repeat the procedure for all days of the week.
Exit? Y/N	After setting the schedule for all the days of the week, following the last entry for Sunday, press the YES key to return to the Status Display Menu or press the NO key to start again at Monday.

Table 7: Four-Event Office Schedule

Event	Event 1		Event 2		Event 3		Event 4	
	Occupied		Unoccupied		Occupied 2		Unoccupied 2	
	Cool	Heat	Cool	Heat	Cool	Heat	Cool	Heat
	72°F (22°C)	70°F (21°C)	80°F (27°C)	62°F (17°C)	72°F (22°C)	70°F (21°C)	80°F (27°C)	62°F (17°C)
Monday	7:00 A.M.		5:00 P.M.		12:00 P.M. ¹		12:00 P.M. ¹	
Tuesday	7:00 A.M.		5:00 P.M.		12:00 P.M. ¹		12:00 P.M. ¹	
Wednesday	7:00 A.M.		5:00 P.M.		12:00 P.M. ¹		12:00 P.M. ¹	
Thursday	7:00 A.M.		5:00 P.M.		7:00 P.M.		10:30 P.M.	
Friday	7:00 A.M.		5:00 P.M.		7:00 P.M.		10:30 P.M.	
Saturday	12:00 P.M. ¹		12:00 P.M. ¹		12:00 P.M. ¹		12:00 P.M. ¹	
Sunday	12:00 P.M. ¹		12:00 P.M. ¹		12:00 P.M. ¹		12:00 P.M. ¹	

1. Programming different events to the same time for that day cancels those events and leaves the thermostat controller in the Unoccupied state.

Setting the Day and Time (T600MSP-4 and T600MSP-4+PIR Models)

Upon initial powerup (or after a power loss of greater than 6 hours), a SetClock alarm appears on the thermostat controller display. As the thermostat controller scrolls through the Status Display Menu, the SetClock alarm message causes the backlight to light up until the clock is set.

When changing the time, press and release the **UP/DOWN** arrow keys once to change the time in 1-minute increments; press and hold down the keys to change the time in 30-minute increments.

To set the clock while in the Main User Menu:

1. Press the **NO** key for all prompts until the clock set prompt appears on the display. Press the **YES** key to enter the clock set menu.
2. Press the **YES** key to set the time or press the **NO** key to advance to the day set menu.
3. Press the **UP/DOWN** arrow keys to adjust the time. When the correct time is displayed, press the **YES** key to store the time.
4. Press the **YES** key to enter the day set menu or press the **NO** key to enter the clock format menu.
5. Press the **UP/DOWN** arrow keys to adjust the day. When the correct day is displayed, press the **YES** key to store the day.
6. Press the **YES** key to choose the time format or press the **NO** key to access the Main User Menu exit prompt.

7. Press the **UP/DOWN** arrow keys to select the desired time format. Press the **YES** key to enter the format.
8. Press the **YES** key to return to the Status Display Menu or press the **NO** key to return to the time set menu.

When the thermostat controller scrolls through the day and time, the new day and time should show on the display and no alarm or backlight should be present. If the day or time is incorrect, repeat the *Setting the Day and Time (T600MSP-4 and T600MSP-4+PIR Models)* procedure.

Setting Schedule Hold

The schedule hold menu is used to set a permanent hold on the internal scheduling or resume the schedule. The permanent hold is typically used for non-scheduled events that extend for long periods of time.

Note: The Override Schedule function is available on the T600MSN-4 and T600MSN-4+PIR models only if DI1 or DI2 is configured for remote NSB.

Note: The Schedule Hold menu is also displayed if DI1 or DI2 is configured for remote NSB.

The following selections are available in the schedule hold menu:

- **Permanent Occupied Hold (occ hold):** This selection puts the thermostat controller into a permanent Occupied state via the Occupied setpoints. Occupied hold appears in the Status Display Menu when this selection is active.

- **Permanent Unoccupied Hold:** This selection puts the thermostat controller into a permanent Unoccupied state via the Unoccupied setpoints. Unoccup hold appears in the Status Display Menu when this selection is active.
- **Resume:** This selection cancels the permanent hold and enables the regular program schedule.

To enable or cancel the permanent hold feature while in the Main User Menu:

1. Press the **NO** key for all prompts until the schedule hold prompt appears on the display. Press the **YES** key to set the schedule hold type.
2. Press the **UP/DOWN** arrow keys to locate the desired permanent hold type (or resume schedule). Press the **YES** key to enter the selection.

3. Press the **YES** key to return to the Status Display Menu or press the **NO** key to change the schedule hold selection again.

Accessories

All the accessories in Table 8 include mounting hardware; contact the nearest Johnson Controls® representative to order any of these parts.

Note: Review the technical specifications of the accessories prior to their use in an application.

Repair Information

If the T600MSx-4 or T600MSx-4+PIR Series Thermostat Controller fails to operate within its specifications, replace the unit. For a replacement thermostat controller, contact the nearest Johnson Controls representative.

Table 8: Accessories (Order Separately)

Code Number	Description
SEN-600-1	Remote Inside Air Temperature Sensor
SEN-600-4	Remote Inside Air Temperature Sensor with Occupancy Override and LED
TE-6361M-1 ¹	Duct Mount Air Temperature Sensor
TE-636S-1 ¹	Strap-Mount Temperature Sensor
TE-6363P-1 ¹	Outside Air Temperature Sensor
TEC-3-PIR ²	Cover with Occupancy Sensor

1. Additional TE-636xx-x Series 10k ohm Johnson Controls Type II Thermistor Sensors are available; refer to the *TE-6300 Series Temperature Sensors Product Bulletin (LIT-216320)* for more details.
2. The TEC-3-PIR Accessory Cover can be used to replace the existing cover on a non-PIR T600MSx-4 Series Thermostat Controller to provide occupancy sensing capability.

Table 9: Display Messages

Display	Function
Service	Indicates that there is a service alarm in accordance with the programmable Digital Inputs (DI1 or DI2).
Filter	Indicates that the filter(s) is dirty in accordance with the programmable Digital Inputs (DI1 or DI2).
Frost on	Indicates that the heating is energized by the low limit frost protection room temperature setpoint.
SetClock	Indicates that there has been a power failure greater than 6 hours and the clock needs to be reset (T600MSP-4 and T600MSP-4+PIR models).
Fan lock	Indicates that the thermostat controller heating or cooling action is locked out because no airflow was detected 10 seconds after the fan (Terminal G) was energized.

Technical Specifications

T600MSx-4 and T600MSx-4+PIR Series Thermostat Controllers

Power Requirements		19 to 30 VAC, 50/60 Hz, 2 VA (Terminals RC and C) at 24 VAC Nominal, Class 2 or Safety Extra-Low Voltage (SELV)
Relay Contact Rating (Y2, Y1, G, W1, W2, and AUX)		30 VAC, 1.0 A Maximum, 3.0 A Inrush, Class 2 or SELV
Digital Inputs		Voltage-Free Contacts across Terminal C to Terminals DI1 and DI2
Wire Size		18 AWG (1.0 mm Diameter) Maximum, 22 AWG (0.6 mm Diameter) Recommended
Temperature Sensor Type		Local 10k ohm Johnson Controls Type II Negative Temperature Coefficient (NTC) Thermistor Sensor
Temperature Range	Backlit Display	-40.0°F/-40.0°C to 122.0°F/ 50.0°C in 0.5° Increments
	Heating Control	40.0°F/4.5°C to 90.0°F/32.0°C
	Cooling Control	54.0°F/12.0°C to 100.0°F/38.0°C
Accuracy	Temperature	±0.9°F/±0.5°C at 70.0°F/21.0°C Typical Calibrated
Minimum Deadband		2°F/1C° between Heating and Cooling
Ambient Conditions	Operating	32 to 122°F (0 to 50°C); 95% RH Maximum, Noncondensing
	Storage	-22 to 122°F (-30 to 50°C); 95% RH Maximum, Noncondensing
Compliance	United States	UL Listed, File E27734, CCN XAPX, Under UL 873, Temperature Indicating and Regulating Equipment
		FCC Compliant to CFR 47, Part 15, Subpart B, Class A
	Canada	UL Listed, File E27734, CCN XAPX7, Under CAN/CSA C22.2 No. 24, Temperature Indicating and Regulating Equipment
		Industry Canada, ICES-003
	Europe	CE Mark, EMC Directive 2004/108/EC
Australia and New Zealand	C-Tick Mark, Australia/NZ Emissions Compliant	
Shipping Weight		0.75 lb (0.34 kg)

The performance specifications are nominal and conform to acceptable industry standards. For application at conditions beyond these specifications, consult the local Johnson Controls office. Johnson Controls, Inc. shall not be liable for damages resulting from misapplication or misuse of its products.



Building Efficiency

507 E. Michigan Street, Milwaukee, WI 53202

Metasys® and Johnson Controls® are registered trademarks of Johnson Controls, Inc. All other marks herein are the marks of their respective owners. © 2009 Johnson Controls, Inc.



CUSTOM AIR PRODUCTS & SERVICES, INC.

35 Southbelt Industrial Drive • Houston, Texas 77047
(713) 460-9009 • Fax (713) 460-9499
www.customairproducts.com

SECTION

04

ELECTRICAL DRAWINGS

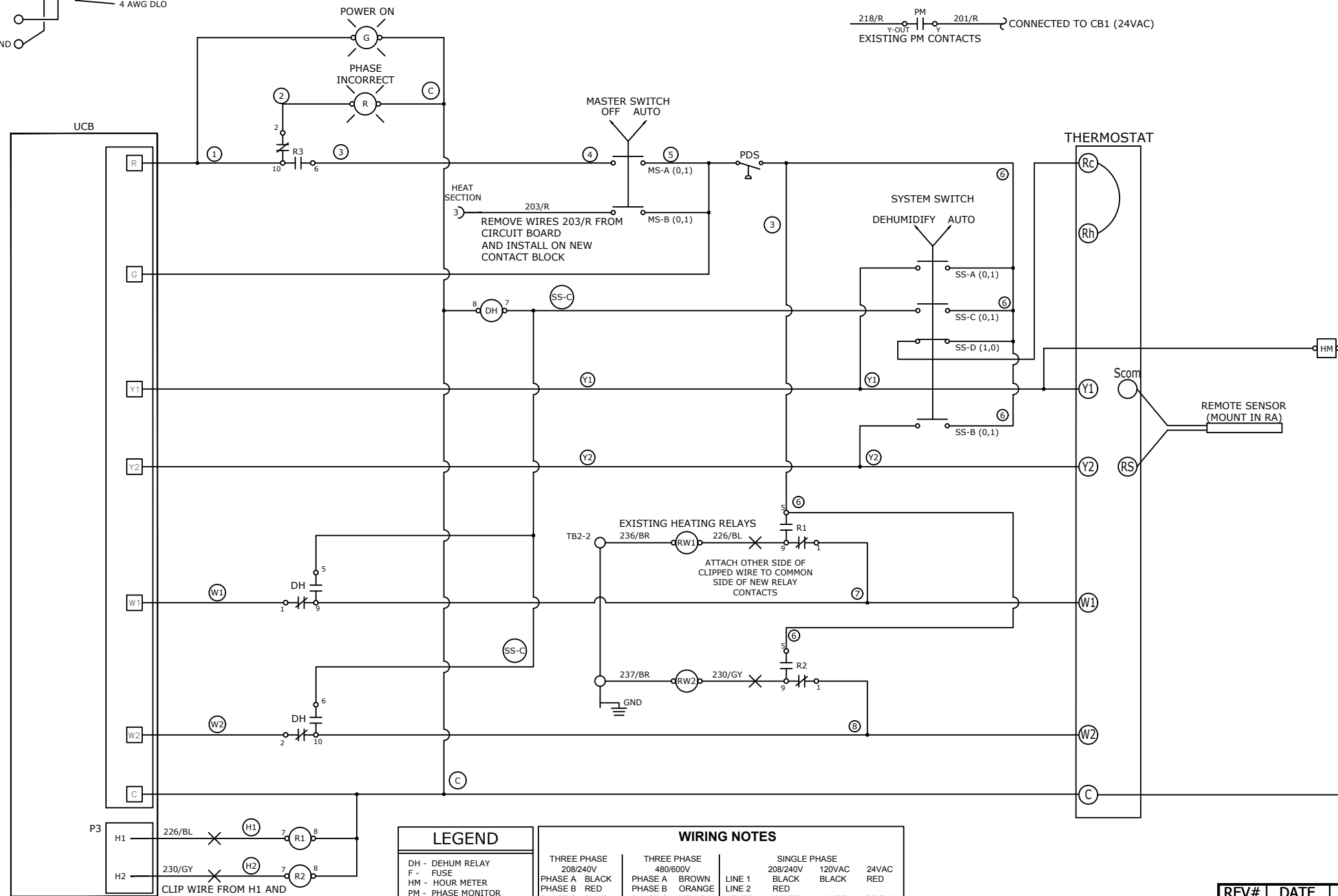
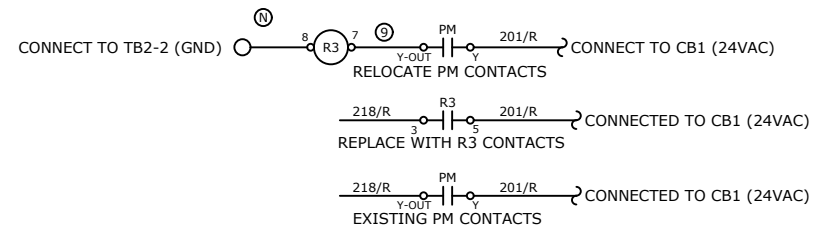
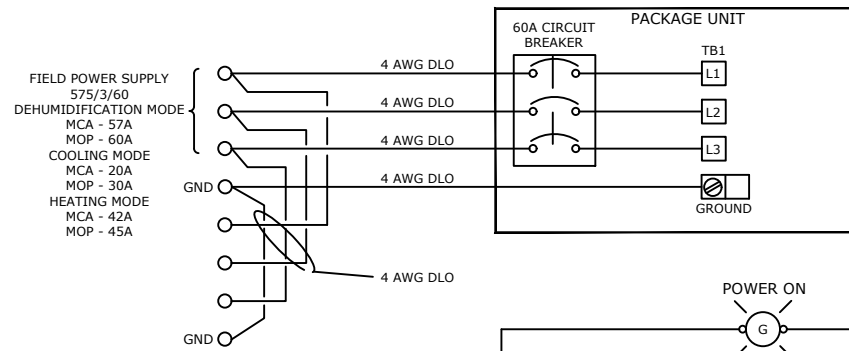

LEGEND	
DH - DEHUM RELAY	
F - FUSE	
HM - HOUR METER	
PM - PHASE MONITOR	
R - RELAY	
SW - SWITCH	
TM - TIMER	

WIRING NOTES		
THREE PHASE 208/240V	THREE PHASE 480/600V	SINGLE PHASE 208/240V 120VAC 24VAC
PHASE A BLACK	PHASE A BROWN	LINE 1 BLACK BLACK RED
PHASE B RED	PHASE B ORANGE	LINE 2 RED
PHASE C BLUE	PHASE C YELLOW	NEUTRAL WHITE WHITE BROWN
NEUTRAL WHITE	NEUTRAL GRAY	24VDC
GROUND GREEN	GROUND GREEN	POSITIVE DARK BLUE
		NEGATIVE GREY

INTRINSICALLY SAFE WIRING SHALL BE LIGHT BLUE 18AWG AND MUST BE SEPARATED FROM ALL OTHER WIRING BY A MINIMUM OF 2". IF CABLE IS USED THE CABLE MUST BE SHIELDED WITH THE SHIELD GROUNDED AT A MINIMUM OF ONE END.
IF VAC WIRING GAUGE IS NOT SPECIFIED USE 18 AWG
IF VDC WIRING GAUGE IS NOT SPECIFIED USE 18 AWG

REV#	DATE	DESIGNER	DESCRIPTION
0	12/07/2017	J.OMALLEY	ISSUED FOR CONSTRUCTION
1	03/28/2018	J.OMALLEY	AS BUILT



35 SOUTHBELT INDUSTRIAL DR., HOUSTON, TX. 77047
PHONE: (713) 460-9009 FAX: (713) 460-9499
TEXAS BOARD OF PROFESSIONAL ENGINEERS
FIRM NUMBER F-14008

THIS DRAWING AND THE INFORMATION HEREIN CONTAINED ARE THE PROPERTY OF CUSTOM AIR PRODUCTS, WHICH HAS FURNISHED THEM IN CONFIDENCE UPON THE UNDERSTANDING AND CONDITION THAT ALL PERSONS, FIRMS OR CORPORATIONS RECEIVING SUCH DRAWINGS AND INFORMATION SHALL BY THE ACT OF RECEIVING THEM BE DEEMED TO HAVE AGREED TO MAKE NO COPY, DUPLICATION, DISCLOSURE OR USE WHATSOEVER OF ALL OR ANY PART THEREOF EXCEPT AS EXPRESSLY AUTHORIZED IN WRITING BY CUSTOM AIR PRODUCTS. NOT TO GIVE, LEND OR OTHERWISE DISPOSE OF THIS DRAWING; AND TO RETURN THIS DRAWING PROMPTLY UPON REQUEST.

CERTIFIED AS-BUILT

CHECKER: _____ DATE: _____
APPROVER: _____ DATE: _____

CAPS NO.:	17F-0861	DRAWING:	E1	DRAWN BY:	J.OMALLEY	DATE:	12/07/2017
CUST. PO#:	5326679	SHEET:	1 OF 2	CHECKED BY:	DAVID NGUYEN	DATE:	12/07/2017
SIZE:	B	REV:	0	APPROVED BY:	LARRY NOVAK	DATE:	03/28/2018

CUSTOMER:	HERC RENTALS
10 TON PACKAGE UNITS WITH 36KW ELECTRIC HEAT GALVANIZED SKID; COATED HOUSING GENERAL PURPOSE; 575V/3P/60HZ ELECTRICAL DESIGN HVAC UNIT WIRING DIAGRAM	

HVAC CONTROL STATION

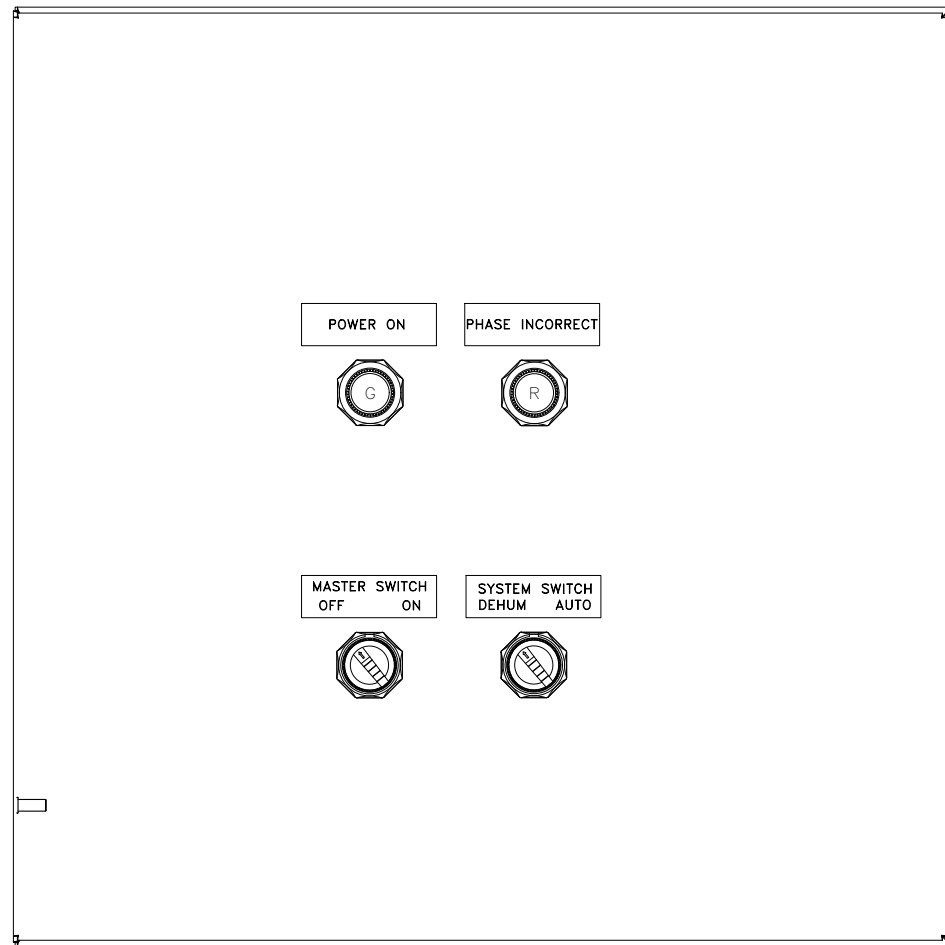

THERMOSTAT (LOCATED ON EXTERIOR OF UNIT)

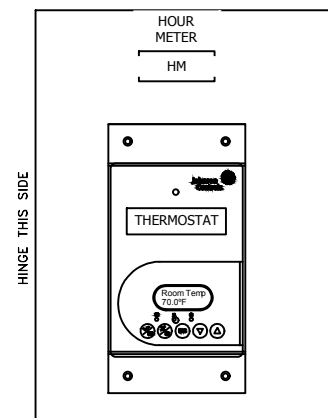

TRANSPARENT RAINPROOF COVER NEMA 4X HINGED

SEQUENCE OF OPERATION

The system is placed into initial operation as follows:

- Turn Master Switch to "OFF" and System Switch to "AUTO"
- Turn Circuit Breaker "ON"
 - If the "Phase Incorrect" light is on, turn off the circuit breaker; reverse two (2) phases of incoming power for proper phase sequencing then check the incoming power source to be sure the unit has a good power source - 460V/3P/60HZ
 - If the "Power On" light is on and the "Phase Incorrect" light is off, the unit is ready for operation
- Turn Master Switch to "ON"
- Set the Thermostat (Auto changeover) to your desired setpoint temperature: Depending on difference between setpoint temperature and air return temperature, unit can operate in cooling or heating mode
- System Switch settings:
 - 1- AUTO: Unit is controlled by the Thermostat
 - 2- Dehum: HVAC controls will bypass the Thermostat and both heat and cool are energized
- Turn the System Switch to "AUTO" then turn Master Switch to "OFF" to turn off the unit

REV#	DATE	DESIGNER	DESCRIPTION
0	12/07/2017	J.OMALLEY	ISSUED FOR CONSTRUCTION
1	03/28/2018	J.OMALLEY	AS BUILT



35 SOUTHBELT INDUSTRIAL DR., HOUSTON, TX. 77047
 PHONE: (713) 460-9009 FAX: (713) 460-9499
 TEXAS BOARD OF PROFESSIONAL ENGINEERS
 FIRM NUMBER P-14008

THIS DRAWING AND THE INFORMATION HEREIN CONTAINED ARE THE PROPERTY OF CUSTOM AIR PRODUCTS, WHICH HAS FURNISHED THEM IN CONFIDENCE UPON THE UNDERSTANDING AND CONDITION THAT ALL PERSONS, FIRMS OR CORPORATIONS RECEIVING SUCH DRAWINGS AND INFORMATION SHALL BY THE ACT OF RECEIVING THEM BE DEEMED TO HAVE AGREED TO MAKE NO COPY, DUPLICATION, DISCLOSURE OR USE WHATSOEVER OF ALL OR ANY PART THEREOF EXCEPT AS EXPRESSLY AUTHORIZED IN WRITING BY CUSTOM AIR PRODUCTS. NOT TO GIVE, LEND OR OTHERWISE DISPOSE OF THIS DRAWING; AND TO RETURN THIS DRAWING PROMPTLY UPON REQUEST.

CERTIFIED AS-BUILT

CHECKER: _____ DATE: _____
 APPROVER: _____ DATE: _____

CAPS NO.:	DRAWING:	DRAWN BY:	DATE:
17F-0861	E2	J.OMALLEY	12/07/2017
CUST. PO#:	SHEET:	CHECKED BY:	DATE:
5326679	2 OF 2	DAVID NGUYEN	12/07/2017
SIZE:	REV:	APPROVED BY:	DATE:
B	0	LARRY NOVAK	03/28/2018

CUSTOMER:	HERC RENTALS
10 TON PACKAGE UNITS WITH 36KW ELECTRIC HEAT GALVANIZED SKID; COATED HOUSING GENERAL PURPOSE; 575V/3P/60HZ ELECTRICAL DESIGN SEQUENCE OF OPERATION	



CUSTOM AIR PRODUCTS & SERVICES, INC.

35 Southbelt Industrial Drive • Houston, Texas 77047

(713) 460-9009 • Fax (713) 460-9499

www.customairproducts.com

SECTION

05

MECHANICAL DRAWINGS

HERC 10 TON PACKAGE UNIT SKID MOUNTED/LIFTING-STACKING CAGE WITH CAMLOK CONNECTIONS

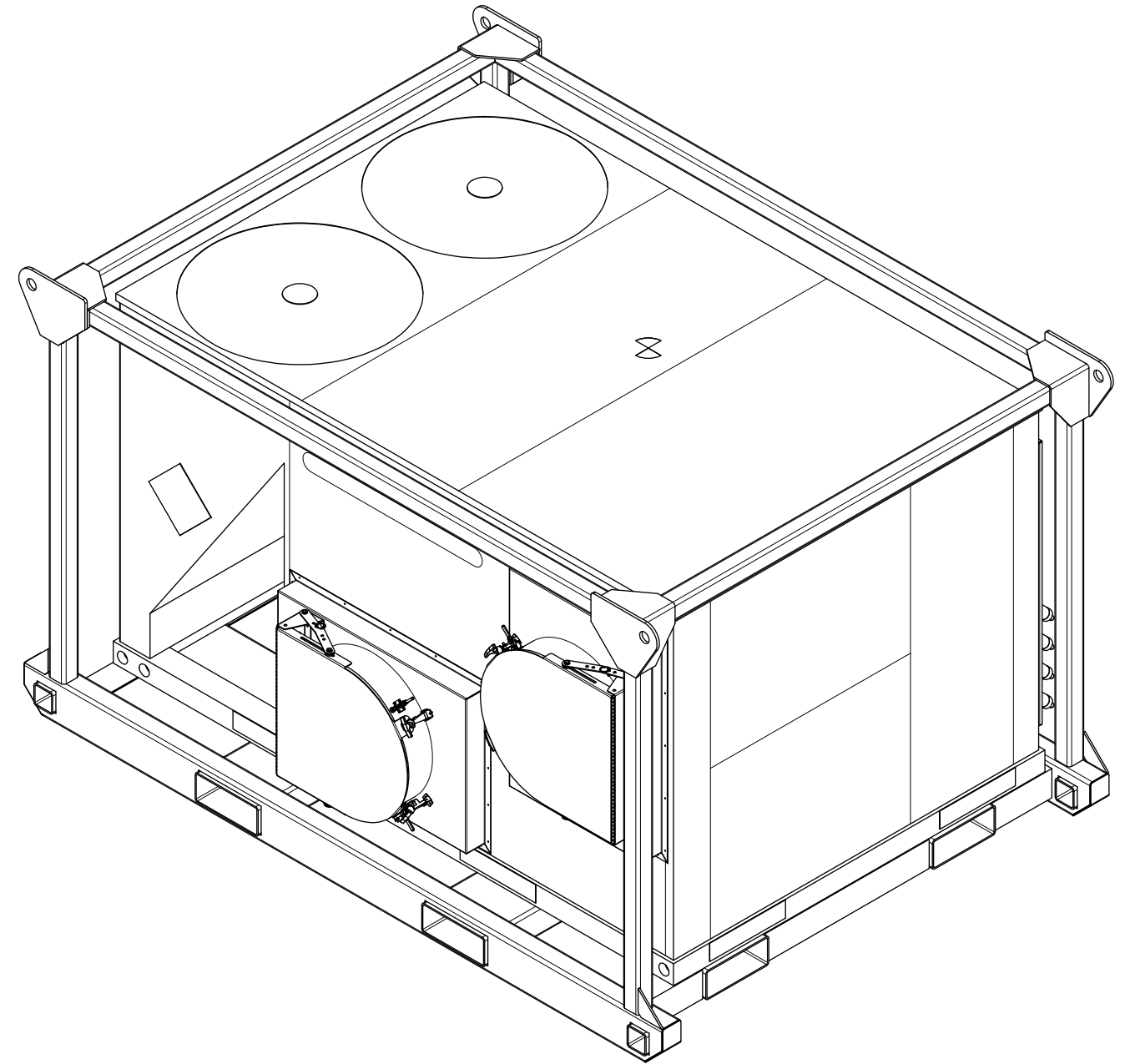
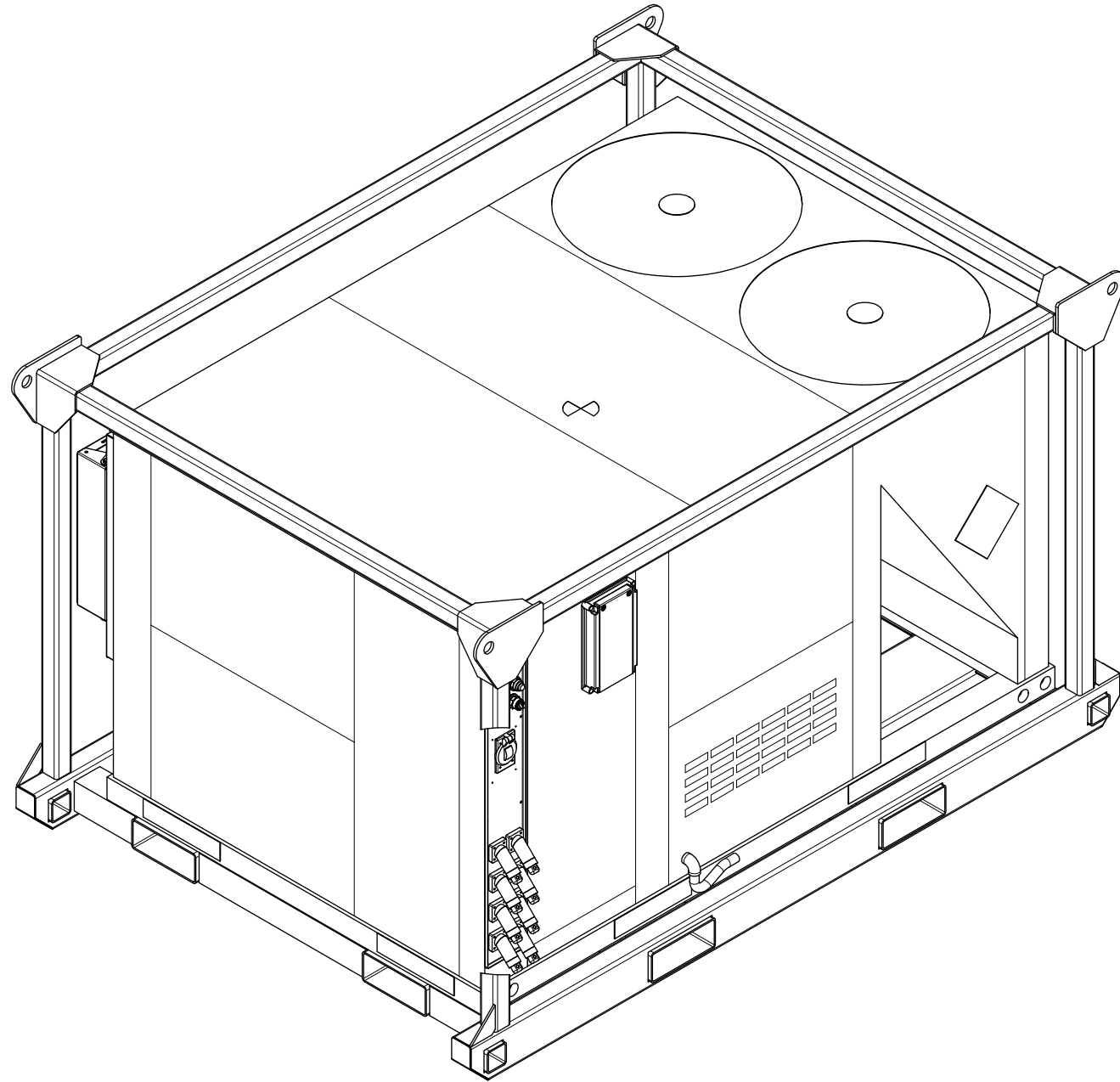

THIS DRAWING AND THE INFORMATION HEREIN CONTAINED ARE THE PROPERTY OF CUSTOM AIR PRODUCTS, WHICH HAS FURNISHED THEM IN CONFIDENCE UPON THE UNDERSTANDING AND CONDITION THAT ALL PERSONS, FIRMS OR CORPORATIONS RECEIVING SUCH DRAWINGS AND INFORMATION SHALL BY THE ACT OF RECEIVING THEM BE DEEMED TO HAVE AGREED: TO MAKE NO COPY, DUPLICATION, DISCLOSURE OR USE WHATSOEVER OF ALL OR ANY PART THEREOF EXCEPT AS EXPRESSLY AUTHORIZED IN WRITING BY CUSTOM AIR PRODUCTS: NOT TO GIVE, LEND OR OTHERWISE DISPOSE OF THIS DRAWING; AND TO RETURN THIS DRAWING PROMPTLY UPON REQUEST.

CERTIFIED AS BUILT

CHECKER: _____ DATE: _____
APPROVER: _____ DATE: _____

CAPS NO.:	DRAWING:	DESIGNER:	DATE:
CUST. PO#:	SHEET:	CHECKER:	DATE:
SIZE:	REV:	APPROVER:	DATE:
SEE NOTE 9 ON G1	1 OF 5	DAVID WASSON	12/6/2017
B	7	JOHN PHAN	12/6/2017

CUSTOMER: **HERC**

**10 TON PACKAGE UNIT
WITH CAMLOK CONNECTIONS
MECHANICAL DESIGN**

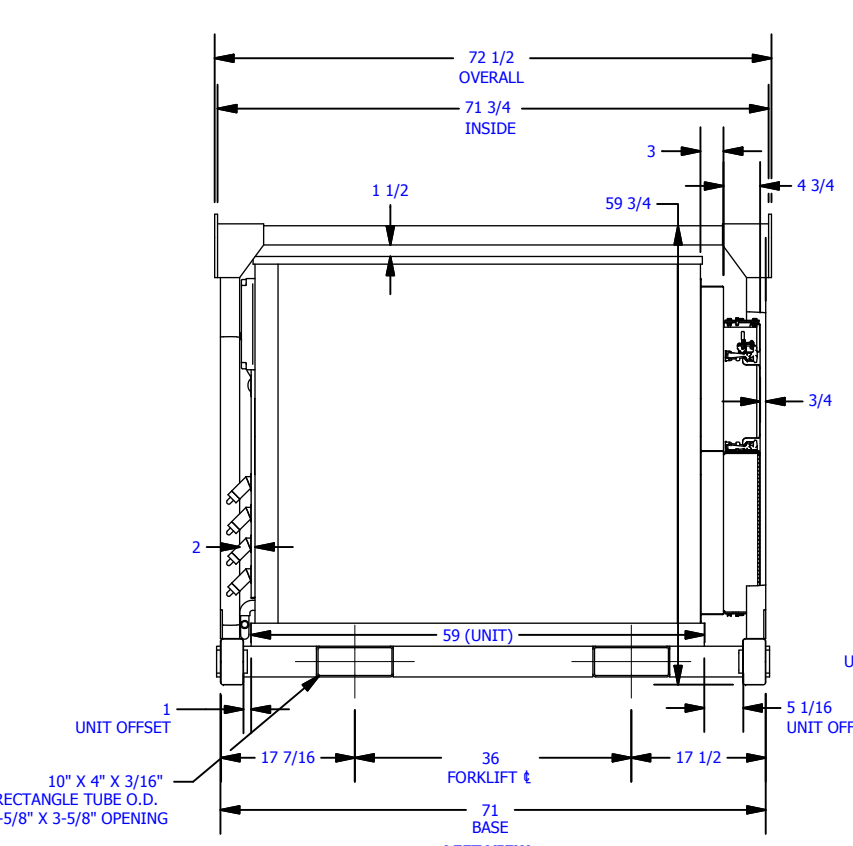
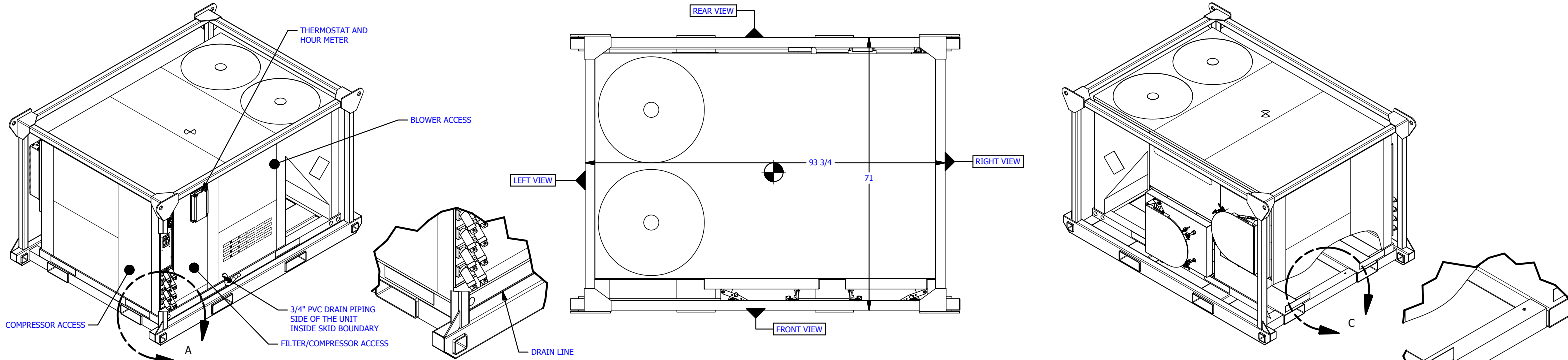

DETAIL A
SCALE 0.06 : 1

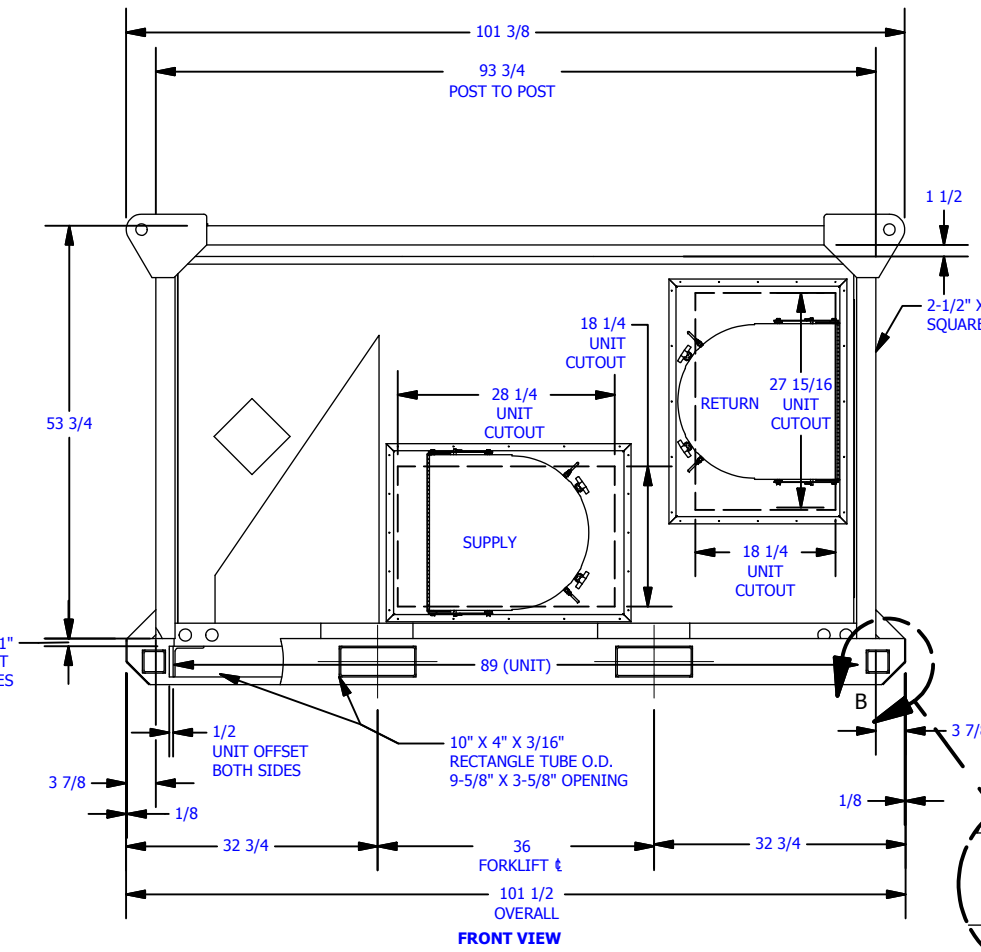

FRONT VIEW

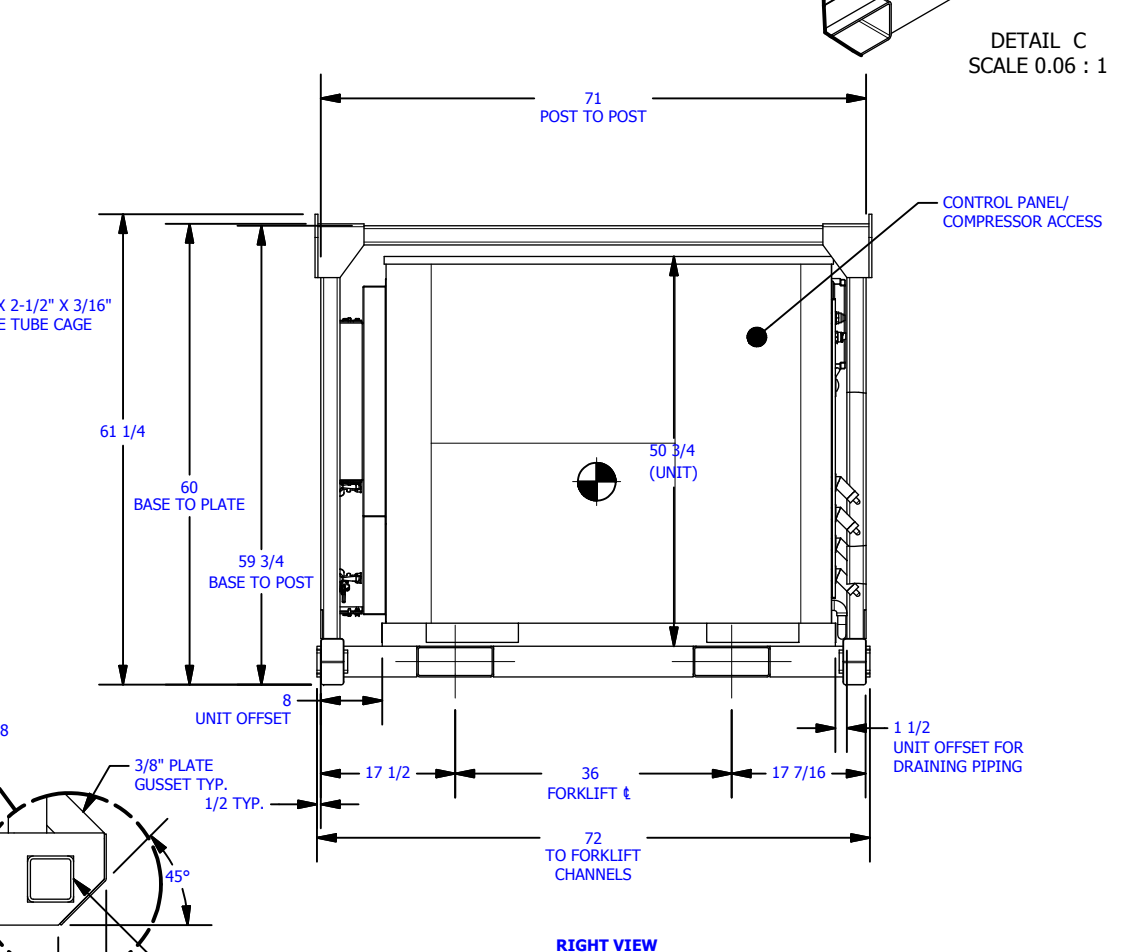

RIGHT VIEW

DETAIL C
SCALE 0.06 : 1

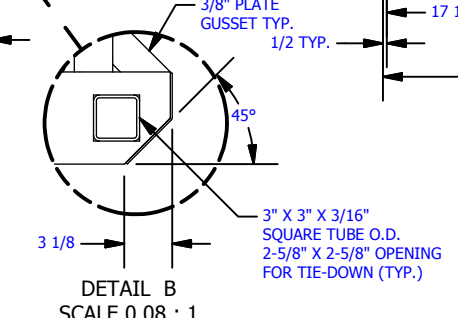

DETAIL B
SCALE 0.08 : 1

UNIT CLEARANCES			
DIRECTION	DISTANCE (in.)	DIRECTION	DISTANCE (in.)
TOP	72	RIGHT	36
FRONT	36	LEFT	12
REAR	36	BOTTOM	0

- NOTES:**
- DIMENSIONS ARE SHOWN IN INCHES UNLESS OTHERWISE NOTED.
 - 20" ROUND DUCT COLLARS PREPARATIONS FOR SUPPLY AND RETURN AIR
 - UNIT IS BOLTED TO SKID.
 - SKID AND CAGE ASSEMBLY ARE CONTINUOUSLY WELDED ALL AROUND ON ALL JOINTS AND HOT DIPPED GALVANIZED COATING PROCESS.
 - UNIT PAINTED/COATED AND CUSTOMER LOGO LOCATIONS PER CUSTOMER SPECIFICATION.
 - UNIT SKID IS PREPARED FOR 1 UNIT STACKED MAX.
 - SOME ELECTRICAL FITTINGS OR PIPING MAY NOT BE SHOWN FOR CLARITY.
 - THERMOSTAT IS INSTALLED INSIDE AIR CONDITIONING UNIT ELECTRICAL PANEL.
 - AIR CONDITIONING MODEL#J10ZFE36N4TZ7 (10 TON, JOHNSON CONTROLS SERIES 20 SINGLE PACKAGED R-410A)
 - TOTAL REAL WEIGHT: 2,200Lbs.
 - PO#: 452572, 452573, 452574, 452575, 452576.



THIS DRAWING AND THE INFORMATION HEREIN CONTAINED ARE THE PROPERTY OF CUSTOM AIR PRODUCTS, WHICH HAS FURNISHED THEM IN CONFIDENCE UPON THE UNDERSTANDING AND CONDITION THAT ALL PERSONS, FIRMS OR CORPORATIONS RECEIVING SUCH DRAWINGS AND INFORMATION SHALL BY THE ACT OF RECEIVING THEM BE DEEMED TO HAVE AGREED: TO MAKE NO COPY, DUPLICATION, DISCLOSURE OR USE WHATSOEVER OF ALL OR ANY PART THEREOF EXCEPT AS EXPRESSLY AUTHORIZED IN WRITING BY CUSTOM AIR PRODUCTS: NOT TO GIVE, LEND OR OTHERWISE DISPOSE OF THIS DRAWING; AND TO RETURN THIS DRAWING PROMPTLY UPON REQUEST.

CERTIFIED AS BUILT

CHECKER: _____ DATE: _____

APPROVER: _____ DATE: _____

CAPS NO.: _____ DRAWING: G1 DESIGNER: ALEX BANNISTER DATE: 12/6/2017

CUST. PO#: SEE NOTE 9 ON G1 SHEET: 2 OF 5 CHECKER: DAVID WASSON DATE: 12/6/2017

SIZE: B REV: 7 APPROVER: JOHN PHAN DATE: 12/6/2017

CUSTOMER: **HERC**

10 TON PACKAGE UNIT

WITH CAMLOK CONNECTIONS

MECHANICAL DESIGN

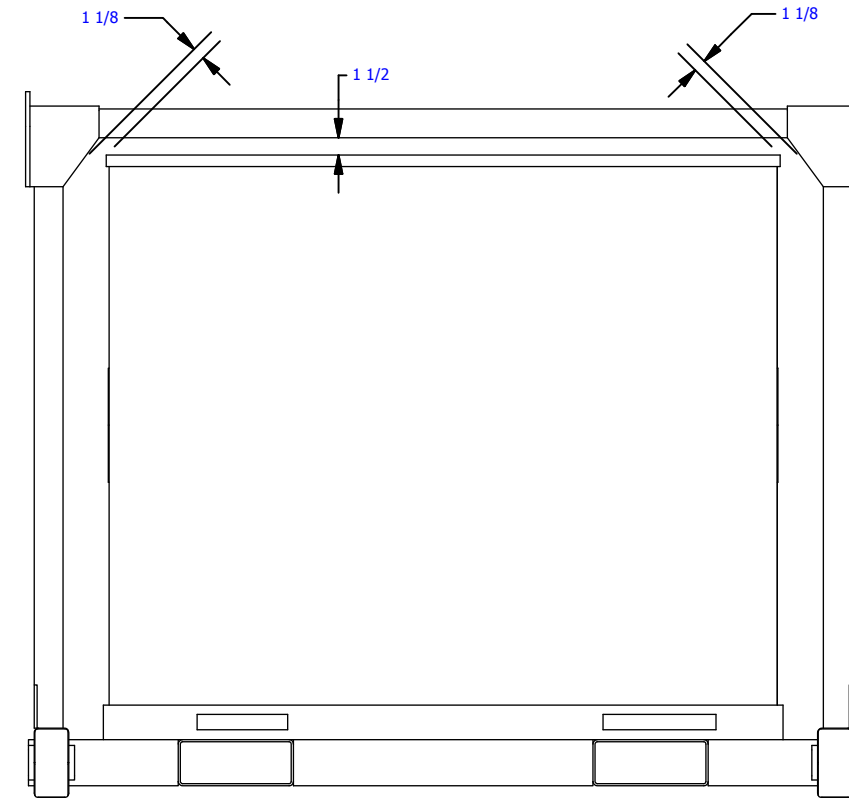
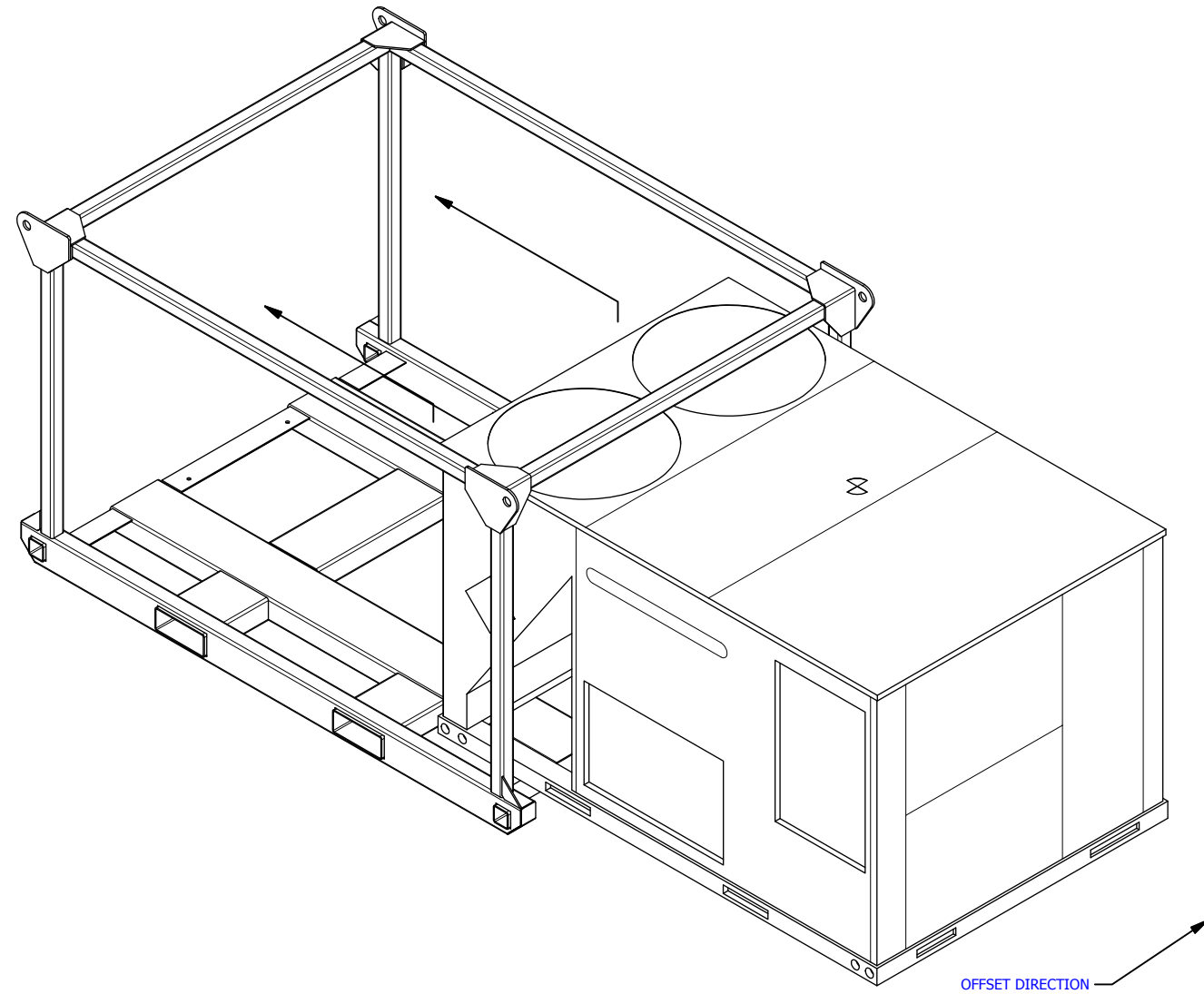

UNIT CLERANCE AND INSTALLATION
 SLIDE UNIT FROM THE END OF THE SKID AND OFFSET
 BASED ON DRAWING G1. THEN SECURE FROM THE
 BOTTOM USING 1/2" HARDWARE



THIS DRAWING AND THE INFORMATION HEREIN CONTAINED ARE THE PROPERTY OF CUSTOM AIR PRODUCTS, WHICH HAS FURNISHED THEM IN CONFIDENCE UPON THE UNDERSTANDING AND CONDITION THAT ALL PERSONS, FIRMS OR CORPORATIONS RECEIVING SUCH DRAWINGS AND INFORMATION SHALL BY THE ACT OF RECEIVING THEM BE DEEMED TO HAVE AGREED: TO MAKE NO COPY, DUPLICATION, DISCLOSURE OR USE WHATSOEVER OF ALL OR ANY PART THEREOF EXCEPT AS EXPRESSLY AUTHORIZED IN WRITING BY CUSTOM AIR PRODUCTS: NOT TO GIVE, LEND OR OTHERWISE DISPOSE OF THIS DRAWING; AND TO RETURN THIS DRAWING PROMPTLY UPON REQUEST.

CERTIFIED AS BUILT

CHECKER: _____ DATE: _____
 APPROVER: _____ DATE: _____

CAPS NO.:
 CUST. PO#:
 SIZE:

SEE NOTE 9 ON G1
 B

DRAWING:
 SHEET:
 REV:

3 OF 5
 7

DESIGNER:
 CHECKER:
 APPROVER:

ALEX BANNISTER
 DAVID WASSON
 JOHN PHAN

DATE:
 DATE:
 DATE:

12/6/2017
 12/6/2017
 12/6/2017

CUSTOMER: **HERC**

**10 TON PACKAGE UNIT
 WITH CAMLOK CONNECTIONS
 MECHANICAL DESIGN**

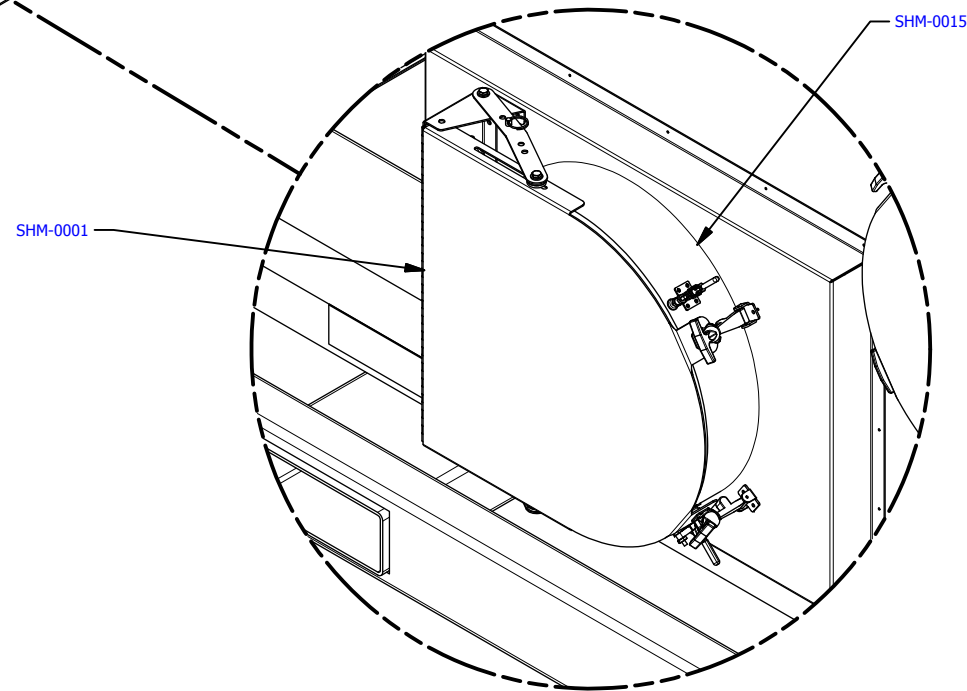
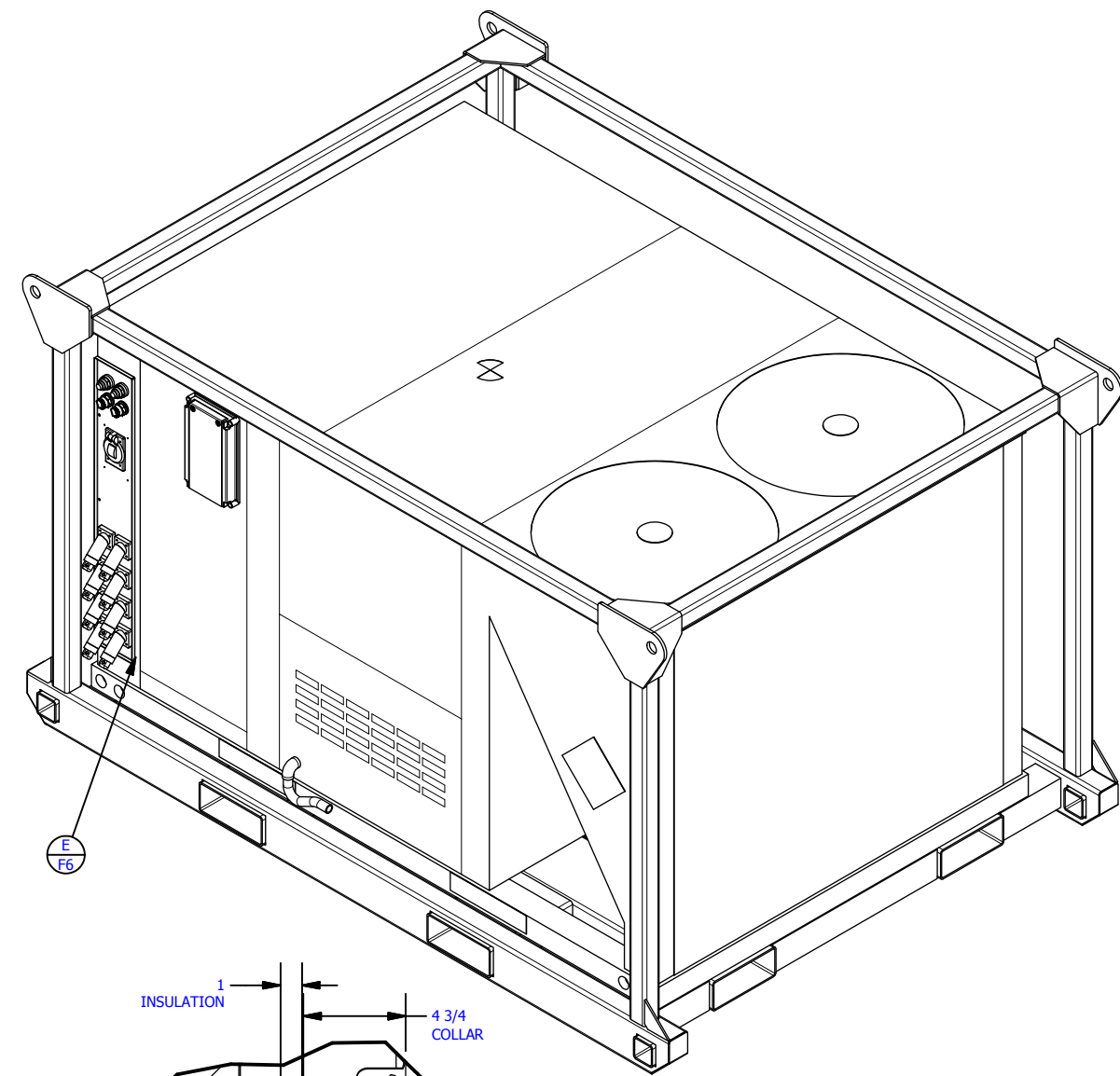
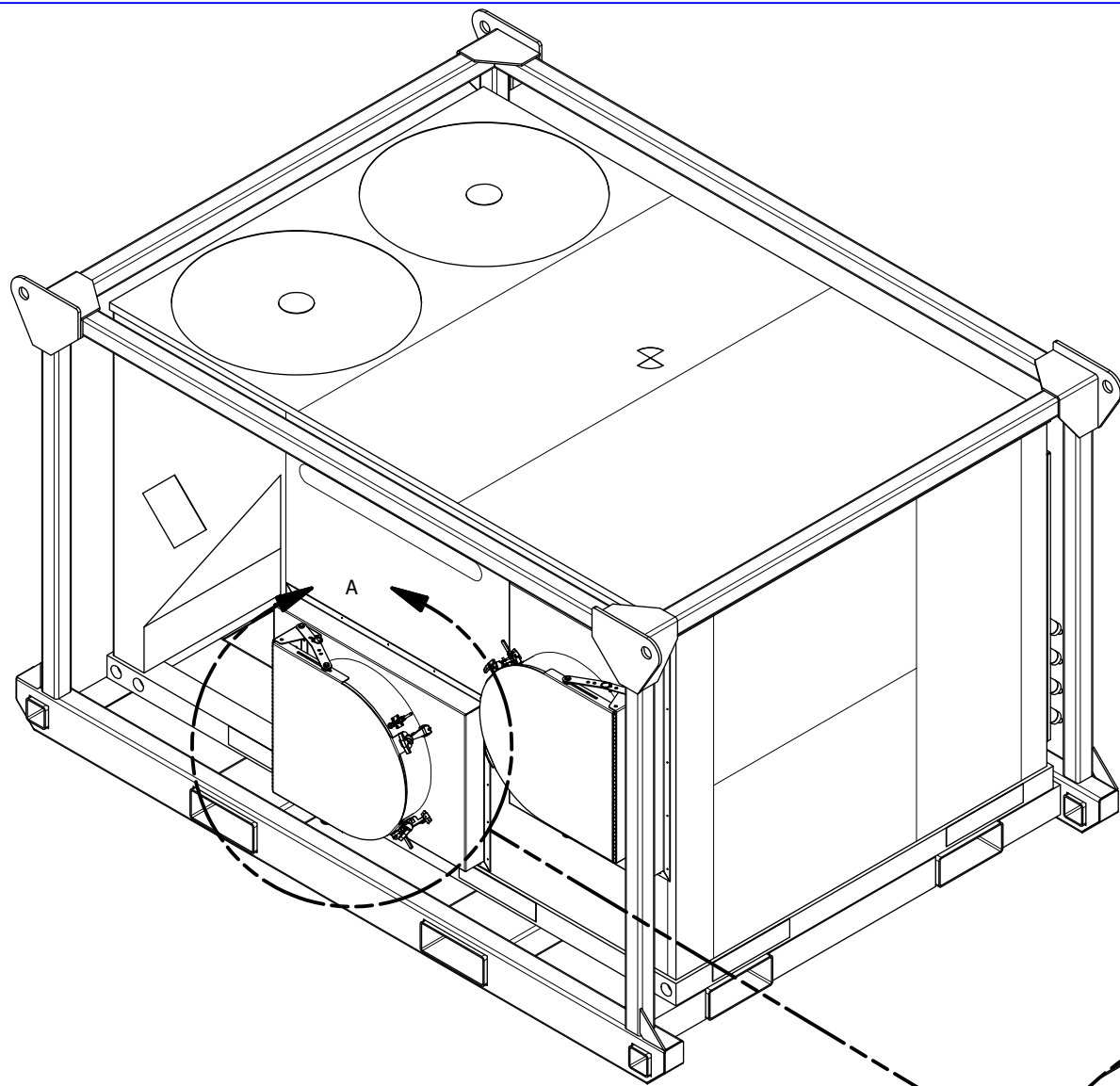

DETAIL A
SCALE 1 / 10

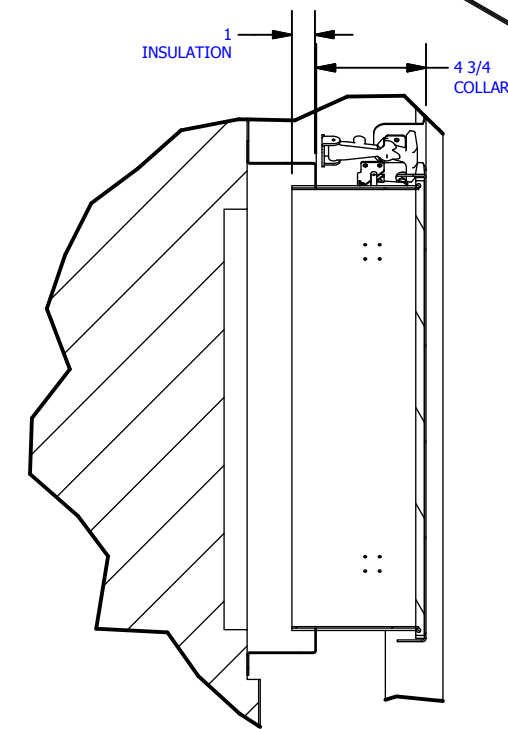

DETAIL B
SCALE 0.12 : 1



THIS DRAWING AND THE INFORMATION HEREIN CONTAINED ARE THE PROPERTY OF CUSTOM AIR PRODUCTS, WHICH HAS FURNISHED THEM IN CONFIDENCE UPON THE UNDERSTANDING AND CONDITION THAT ALL PERSONS, FIRMS OR CORPORATIONS RECEIVING SUCH DRAWINGS AND INFORMATION SHALL BY THE ACT OF RECEIVING THEM BE DEEMED TO HAVE AGREED: TO MAKE NO COPY, DUPLICATION, DISCLOSURE OR USE WHATSOEVER OF ALL OR ANY PART THEREOF EXCEPT AS EXPRESSLY AUTHORIZED IN WRITING BY CUSTOM AIR PRODUCTS: NOT TO GIVE, LEND OR OTHERWISE DISPOSE OF THIS DRAWING; AND TO RETURN THIS DRAWING PROMPTLY UPON REQUEST.

CERTIFIED AS BUILT	
CHECKER: _____	DATE: _____
APPROVER: _____	DATE: _____

CAPS NO.:	DRAWING:	DESIGNER:	DATE:
		ALEX BANNISTER	12/6/2017
CUST. PO#:	SHEET:	CHECKER:	DATE:
SEE NOTE 9 ON G1	4 OF 5	DAVID WASSON	12/6/2017
SIZE:	REV:	APPROVER:	DATE:
B	7	JOHN PHAN	12/6/2017

CUSTOMER:	HERC
10 TON PACKAGE UNIT WITH CAMLOK CONNECTIONS MECHANICAL DESIGN	

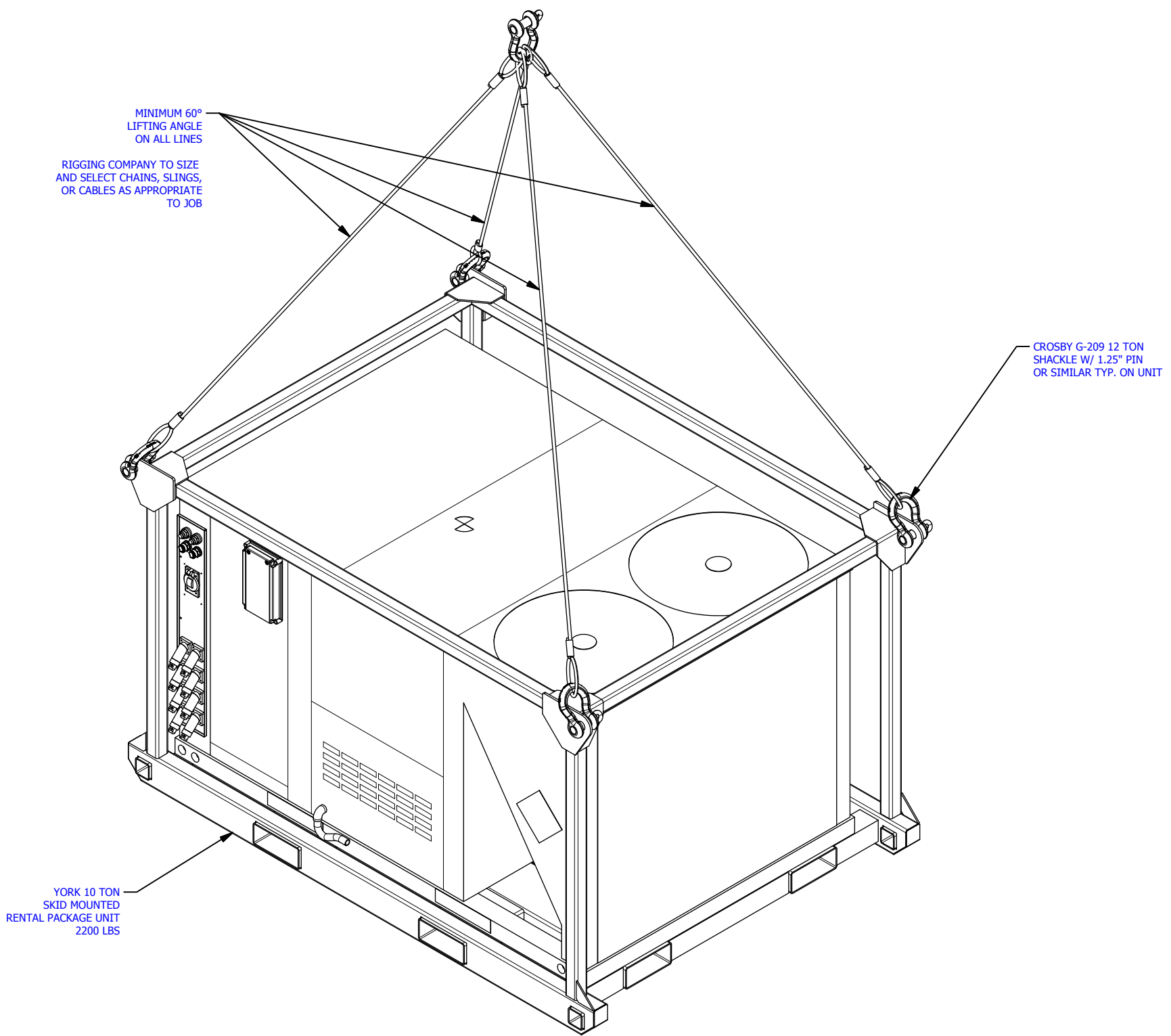

THIS DRAWING AND THE INFORMATION HEREIN CONTAINED ARE THE PROPERTY OF CUSTOM AIR PRODUCTS, WHICH HAS FURNISHED THEM IN CONFIDENCE UPON THE UNDERSTANDING AND CONDITION THAT ALL PERSONS, FIRMS OR CORPORATIONS RECEIVING SUCH DRAWINGS AND INFORMATION SHALL BY THE ACT OF RECEIVING THEM BE DEEMED TO HAVE AGREED: TO MAKE NO COPY, DUPLICATION, DISCLOSURE OR USE WHATSOEVER OF ALL OR ANY PART THEREOF EXCEPT AS EXPRESSLY AUTHORIZED IN WRITING BY CUSTOM AIR PRODUCTS; NOT TO GIVE, LEND OR OTHERWISE DISPOSE OF THIS DRAWING; AND TO RETURN THIS DRAWING PROMPTLY UPON REQUEST.

CERTIFIED AS BUILT

CHECKER: _____ DATE: _____
 APPROVER: _____ DATE: _____

CAPS NO.:	DRAWING:	DESIGNER:	DATE:
		ALEX BANNISTER	12/6/2017
CUST. PO#:	SHEET:	CHECKER:	DATE:
SEE NOTE 9 ON G1	5 OF 5	DAVID WASSON	12/6/2017
SIZE:	REV:	APPROVER:	DATE:
B	7	JOHN PHAN	12/6/2017

CUSTOMER: **HERC**

**10 TON PACKAGE UNIT
WITH CAMLOK CONNECTIONS
MECHANICAL DESIGN**



CUSTOM AIR PRODUCTS & SERVICES, INC.

35 Southbelt Industrial Drive • Houston, Texas 77047

(713) 460-9009 • Fax (713) 460-9499

www.customairproducts.com

SECTION

06

SPARE PARTS LIST

SUGGESTED SPARE PARTS

SUGGESTED SPARE PARTS						
JOB #:	17F-0861		REVISION #: 0			
CUSTOMER	HERC RENTALS					
PROJECT	2018 RENTAL FLEET					
ITEM #	DESIGNATION	BRAND	MODEL/PART #	DESCRIPTION	QTY	CAPS#
1	SWITCHES	SQUARE D	9001KS11B	2 POSITION SWITCH	1	
2	CONTACT BLOCK	SQUARE D	9001KA2	NO CONTACT BLOCK	1	
3	CONTACT BLOCK	SQUARE D	9001KA1	NC CONTACT BLOCK	1	
4	PILOT LIGHT, POWER ON	SQUARE D	9001KP35G31	PILOT LIGHT GRN 24VAC/DC 30MM	1	
5	PILOT LIGHT, PHASE INCORRECT	SQUARE D	9001KP35R31	PILOT LIGHT RED 24VAC/DC 30MM	1	
6	AIR FLOW SWITCH	DWYER	1910-00	DIFFERENTIAL PRESSURE SWITCH	1	
7	CB	SQUARE D	HDL36060	60A CIRCUIT BREAKER, 600VAC	1	
8	RELAYS - R1, R2, R3, DH	WAGO	788-512	DPDT RELAY, 24VAC	1	
9	THERMOSTAT	VICONICS	VT7600B5000	TEMPERATURE STAGE CONTROL MODULE	1	
10	REMOTE SENSOR	VICONICS	S1010E1000	REMOTE INDOOR SENSOR, 10K OHMS	1	
11	TIMER	ICM	ICM102B	TIMER	1	
12	HM	RDG	3410-000	HOUR METER	1	