



CUSTOM AIR PRODUCTS & SERVICES, INC.

35 Southbelt Industrial Drive • Houston, Texas 77047

(713) 460-9009 • Fax (713) 460-9499

www.customairproducts.com

HERC

2018 FLEET

17F-0868

40 TON COMPACT SERIES

GALV SKID, GALV CAGE, STAINLESS STEEL HOUSING

NEMA 4, VFD CONTROL, R-410A

117KW HEATER

460V/3PH/60HZ

GENERAL PURPOSE

8/7/2018

INSTALLATION & OPERATION MANUAL

BOOK ASSEMBLED BY: JONATHAN O'MALLEY

DATE: 8/7/2018

**Table
Of
Contents
17F-0868**

JOB SCOPE	1
EVAPORATOR SELECTION	2
CONDENSER SELECTION	3
COMPRESSOR SELECTION	4
HEATER SELECTION	5
MISC. COMPONENTS	6
ELECTRICAL DRAWINGS	7
MECHANICAL DRAWINGS	8
SPARE PARTS LIST	9



CUSTOM AIR PRODUCTS & SERVICES, INC.

35 Southbelt Industrial Drive • Houston, Texas 77047

(713) 460-9009 • Fax (713) 460-9499

www.customairproducts.com

SECTION

01

JOB SCOPE



Quote No:	DW17-11-18-18
Quote Date:	11-18-2017
Project Type:	(13) 40 Ton Compact Hybrid Multi-Purpose Custom Package Unit
Drawing Delivery:	2 weeks after receipt of order
Equipment Delivery:	14-16 weeks After Receipt of Approved Drawings (ARAD)
Freight Terms:	FOB HERC
Payment Terms:	Net 45 *100% upon completion

Item	Qty	Description		
1.	13	<p>CAPS Model#: PPKH-40TD-0NN120KE-5E5-P2-VS1CEUP</p> <p>Unit shall consist of the following factory-installed components:</p> <ul style="list-style-type: none"> • Evaporative Section with: <ul style="list-style-type: none"> ○ Belt Drive Plenum Fan ○ High static belt drive evaporator fan is capable of handling 4.25" total static pressure @ 14,000 CFM with VFD for varying CFM of the unit with potentiometer on main control panel. ○ TEFC High Efficiency Motor ○ Dual Circuit Direct Expansion Evaporative Coil <ul style="list-style-type: none"> ▪ Entering air conditions (dry / wet bulb)= 80F/67F ▪ Leaving air conditions (dry / wet bulb)= 55F/55F ○ 117 kW Three (3) Stage Electric Heating Coil ○ 2" Flat Filter Tracks • Refrigeration Section with two (2) independent circuits. Each circuit shall consist of: <ul style="list-style-type: none"> ○ Three (3) Direct Drive axial flow fans controlled by VFD to maintain constant head pressure and provide quiet operation ○ Condensing fans blades shall be constructed out of aluminum ○ Condensing fan motors shall have shaft grounding ring installed ○ Independent Condensing Coils ○ Independent scroll compressors with compressor protection module ○ Hot gas bypass regulator with isolation valve ○ Low pressure safety ○ High pressure safety ○ Stainless steel vibra-sorbers installed at the suction and discharge line of each compressor ○ Thermostatic expansion valves with equalizer line connection ○ Liquid line sight glasses ○ Liquid line filter driers • Estimated unit size is 84" Wide x 126" Long x 101.5" High 		

Item	Qty	Description		
		<ul style="list-style-type: none"> • Unit shall be furnished include an Electrical Control Panel enclosure with the following components and features: <ul style="list-style-type: none"> ○ 480 / 3 /60 primary power supply ○ Main circuit breaker with panel mounted safety lever latch ○ Control power transformer with primary and secondary fuses ○ Electric heating element fuses ○ Heating and compressor contactors ○ VFD only control for both the evaporator and condenser fan motors ○ Electrical panel ventilation fan and intake filter / louver ○ Leaving air controller with sensor for constant discharge air control utilizing the evaporator fan VFD ○ Airflow switch ○ High limit switch ○ Phase monitor ○ On/Off selector switch ○ Pilot lights (power and phase incorrect) ○ 4/0 cam-lock terminals will be provided for power hookup. ○ DH Mode controls ○ Three (3) stage heat and two (2) stage cool thermostat with remote sensor ○ Leaving air controller with sensor for VAV operation ○ Hour meters <p>CERTIFIED SKID</p> <ul style="list-style-type: none"> • The unit shall be furnished with a certified skid. The skid shall be fabricated from structural tubing. The skid is constructed in length and width so that no part of the unit is outside of the rack. The fork truck lifting slots are made of 10" X 4" rectangular steel tube on two (2) sides and are incorporated into the design on centers and are 42" apart. The skid components are continuously welded at all joints. The skid shall be hot dipped galvanized. <p>CERTIFIED CAGE</p> <ul style="list-style-type: none"> • The lifting frame material shall be 3" X 3" square steel tubing. This frame is designed for certified overhead lifting and stacking of the units. All tubing ends are capped and continuously welded. The tubing is cut and fit to the height, width, and length of the unit. All corners have a 45 degree, 3/8" steel plate gusset. The top of the frame has a 3/8" steel plate superman gusset welded to the horizontal tubing and incorporates a 1½ inch hole that aligns with the drag eye to secure stacking of units. The cage shall be bolted to the skid with grade 8 hardware. The entire cage will be hot dipped galvanized. <p>UNIT FRAME, CABINET, AND BASE</p> <ul style="list-style-type: none"> • The air handling unit panel casing system shall be built up from the unit base, using a structural aluminum extrusion framing system. The framing system assembly shall be accomplished using structural members and mechanical fasteners. Precision die cast aluminum corners (three-way) joining elements shall be used to connect the perimeter enclosure framing (profile) members. Vertical and horizontal wall, roof, and floor supports, or "omega" extrusions, shall be incorporated and spaced to enable the finished enclosure to withstand the system design static pressures as listed on the equipment schedule. The omega wall, roof, and floor supports shall include a track-way to capture and secure fastener (bolt) heads. 		

Item	Qty	Description		
		<ul style="list-style-type: none"> • Standard aluminum structural angle and channel extrusions are to be then bolted in place to the omega members to form interior walls and mounting brackets retainers anchor points. Structural framing profiles and omega supports shall be extruded from 6063 alloy T5 temper aluminum as a minimum. • The unit shall be single wall constructed. The exterior panel sheet shall be 16 gauge 304 Stainless Steel. A thermal break consisting of a double-back tape or gasket shall be installed between all of the housing sheeting and the structural frame. Mechanical fasteners such as stainless steel screws or rivets shall also be employed to secure the housing sheeting to the structural members. • The housing panels shall be installed to seat against the unit pressure where possible, that is, against the flange of the structure framing. • Panels shall be joined together with a neat and clean appearance. Any safing, internal partitions, or other tie-ins to the casing shall be made using internal support angle extrusions or panels that are a part of the casing. Such members may be bolted, screwed, or riveted to or through the support structure. • Conservative casing/structural design standards as outlined above shall assure the owner that unit damage (e.g. panel blowouts, collapsing, or buckling) can be avoided due to a system catastrophic event, such as an inadvertent damper closure. The installed housing panel design shall comply with NFPA-90A. <p>ACCESS DOORS</p> <ul style="list-style-type: none"> • Each unit section shall have an access door, removable plug panel, or special service feature for motor removal as outlined. Through properly designed access, ease of maintenance, and removability of components, unit serviceability shall be assured. • Access doors and removable panels shall be double wall construction. They shall be guaranteed tight closing by means of a continuous separate gasket seal around the entire door periphery, to assure a true perpendicular, tight, non-shearing compression fit. <p>FLEX DUCT INTERFACE CONNECTION</p> <ul style="list-style-type: none"> • The unit supply and return air section shall include a framed opening for supply or return air flex duct connections. • Units shall be furnished with (3) 20" supply and (6) 20" return duct collars constructed of 304 Stainless Steel. • All corners shall be continuously welded to prevent leakage. • Each duct collar shall be furnished with a cap lined with a 3/8" gasket. Cap shall be attached with a stainless steel hinge and held close with (2) rubber hood type latches. Each duct collar shall be furnished with (4) duct clamps to hold flex duct in place. • Each collar shall have a damper fabricated from 1/2" stainless steel rod welded to a 14 gauge stainless steel damper. A seven (7)-position steel quadrant is welded in place for CFM adjustment. <p>INSULATION</p> <ul style="list-style-type: none"> • Each section shall be factory insulated. Insulation shall have full coverage waterproof adhesive to firmly secure the material to the unit casing. Insulation shall meet the erosion requirements of UL 181. • 1" Thermax foam board – Panels shall have a R – value of 6.50 		

Item	Qty	Description		
		<p>DRAIN PAN</p> <ul style="list-style-type: none"> • All drain pans shall be fabricated from types 304 stainless steel. • One drain outlet shall be supplied for each cooling coil section. • Drain pan shall allow no standing water and comply with ASHRAE Standard 62-R. Where 2 or more coils are installed in a coil bank, intermediate drain pans shall be provided that extend a minimum of 6 in. from the downstream side of the upper coil face and the condensate shall be piped to the bottom drain pan. <p>COILS</p> <ul style="list-style-type: none"> • All condensing and direct expansion (DX) refrigerant coils shall be provided to meet the scheduled performance. All coil performance shall be certified in accordance with ARI Standard 410. All water and direct expansion coils shall be tested at 315 psig air pressure. • General Fabrication: <ul style="list-style-type: none"> ○ All refrigerant coils shall have 3/8" or 1/2" OD seamless copper tubes mechanically expanded into fins to ensure high thermal performance. Minimum tube wall thickness shall be 0.016 inches. ○ Aluminum plate fin type with belled collars supplied with die formed casing and tube sheets of mill galvanized steel. Minimum fin thickness shall be 0.0060 inches. • Refrigerant Coils: <ul style="list-style-type: none"> ○ Headers shall be seamless copper tubes with brazed joints. ○ Coils shall be provided with a brass liquid distributor with solder type connection. Distributors shall have removable brass venture (nozzles). Distributors to coil capillary feeder tubes shall be seamless copper. ○ Coils for full face-active or face-split operation shall have intertwined circuits for equal loading on each circuit. Suction and liquid connections shall be on the same end. ○ Both evaporator and condenser coils shall be coated with EnergyGuard • Electric Heating Section: <ul style="list-style-type: none"> ○ Coils shall be open-wire type, 80% nickel, 20% chromium resistance coils, insulated by floating ceramic bushings and supported in a galvanized steel frame. Bushings shall be recessed into embossed openings and stacked into supporting brackets, spaced no more than 4-inch centers. Maximum element heating density shall be 55 watts/sq. inch. <p>EVAPORATIVE FAN & MOTOR</p> <ul style="list-style-type: none"> • Evaporative fan section shall have one single width single inlet (SWSI) direct drive airfoil fan wheel. Fan shall have a fully welded aluminum centrifugal wheel. They shall be designed for continuous operation at the maximum rated fan speed and motor horsepower. Fans shall have a minimum of AMCA Class II rating. Motor shall have a shaft grounding ring installed. • Fan motor shall be mounted within the fan section. Motor shall be high efficiency, totally enclosed fan cooled NEMA Design B with size and electrical characteristics as shown on the equipment schedule. All motors shall have a ±10% voltage utilization range and a 1.15 minimum service factor. Motor shall be compliant with EPACK where applicable and rated for VFD operation. Motor shall have shaft grounding ring installed. 		

Item	Qty	Description																									
		<p>CONDENSING FANS & MOTORS</p> <ul style="list-style-type: none"> Condensing fan section shall have three (3) direct drive axial flow fans. Fan blades shall be constructed of glass reinforced polyamide nylon or aluminum. Motors shall be air over mounted in a vertical arrangement with slingers to protect motor bearings from moisture. Condensing fan assemble shall be removable from the exterior of the unit. Motor shall have shaft grounding ring installed. <p>FILTER SECTION</p> <ul style="list-style-type: none"> Filters shall be mounted in a 2" track installed on the inlet airside of the unit. The filters shall be slip in, 2" - 30% pleats. Blank-offs shall be sealed and caulked. <p>ADDITIONAL FEATURES</p> <ul style="list-style-type: none"> Compressors, piping and control panels shall be coated with 2-part polyurethane coating – Herc specified color white CAPS will provide and install Herc marketing package Units will be tested, logged and documented at CAPS facility with Herc personnel welcome during testing if required. Herc Representatives will also have full access to schedules and production progress as units are being manufactured. 																									
		<table border="1"> <thead> <tr> <th>PKG</th> <th>CFM</th> <th>ESP</th> <th>TSP</th> <th>MOTOR HP</th> </tr> </thead> <tbody> <tr> <td>PKG-1</td> <td>14,000</td> <td>3.00</td> <td>4.25</td> <td>15</td> </tr> </tbody> </table>	PKG	CFM	ESP	TSP	MOTOR HP	PKG-1	14,000	3.00	4.25	15															
PKG	CFM	ESP	TSP	MOTOR HP																							
PKG-1	14,000	3.00	4.25	15																							
		<table border="1"> <thead> <tr> <th colspan="5">COOLING COIL</th> </tr> <tr> <th>PKG</th> <th>FPM</th> <th>EAT: DB / WB</th> <th>LAT: DB / WB</th> <th>MBH TOTAL</th> </tr> </thead> <tbody> <tr> <td>PKG-1</td> <td>505</td> <td>80.0 / 67.0</td> <td>55.0 / 55.0</td> <td>494.0</td> </tr> <tr> <th>MBH SENSIBLE</th> <th>ROW(S) / FPI</th> <th>REFG.</th> <th>SUCT. TEMP</th> <th>SUPER HEAT</th> </tr> <tr> <td>363.0</td> <td>6 / 9</td> <td>410A</td> <td>45.0</td> <td>20.0</td> </tr> </tbody> </table>	COOLING COIL					PKG	FPM	EAT: DB / WB	LAT: DB / WB	MBH TOTAL	PKG-1	505	80.0 / 67.0	55.0 / 55.0	494.0	MBH SENSIBLE	ROW(S) / FPI	REFG.	SUCT. TEMP	SUPER HEAT	363.0	6 / 9	410A	45.0	20.0
COOLING COIL																											
PKG	FPM	EAT: DB / WB	LAT: DB / WB	MBH TOTAL																							
PKG-1	505	80.0 / 67.0	55.0 / 55.0	494.0																							
MBH SENSIBLE	ROW(S) / FPI	REFG.	SUCT. TEMP	SUPER HEAT																							
363.0	6 / 9	410A	45.0	20.0																							
		<table border="1"> <thead> <tr> <th colspan="5">HEATING COIL</th> </tr> <tr> <th>PKG</th> <th>KW</th> <th>STAGE(S)</th> <th>VOLT/PH/HZ</th> <th>CONTROL VOLTAGE</th> </tr> </thead> <tbody> <tr> <td>PKG-1</td> <td>117</td> <td>3</td> <td>480 / 3 /60</td> <td>24</td> </tr> </tbody> </table>	HEATING COIL					PKG	KW	STAGE(S)	VOLT/PH/HZ	CONTROL VOLTAGE	PKG-1	117	3	480 / 3 /60	24										
HEATING COIL																											
PKG	KW	STAGE(S)	VOLT/PH/HZ	CONTROL VOLTAGE																							
PKG-1	117	3	480 / 3 /60	24																							
		<table border="1"> <thead> <tr> <th colspan="5">FILTERS</th> </tr> <tr> <th>PKG</th> <th>SIZE</th> <th>EFE.</th> <th>TYPE</th> <th>ARRANGEMENT</th> </tr> </thead> <tbody> <tr> <td>PKG-1</td> <td>2"</td> <td>30%</td> <td>PLEATED</td> <td>FLAT</td> </tr> </tbody> </table>	FILTERS					PKG	SIZE	EFE.	TYPE	ARRANGEMENT	PKG-1	2"	30%	PLEATED	FLAT										
FILTERS																											
PKG	SIZE	EFE.	TYPE	ARRANGEMENT																							
PKG-1	2"	30%	PLEATED	FLAT																							

Item	Qty	Description		
		<p><u>EXCLUSIONS</u></p> <ul style="list-style-type: none">• Installation, Equipment and Start-up Commissioning by others• Sales tax not included• Freight not included• Overtime not included• Proposal valid for 30 days• Any items not listed in the above scope of work to be performed		



CUSTOM AIR PRODUCTS & SERVICES, INC.

35 Southbelt Industrial Drive • Houston, Texas 77047

(713) 460-9009 • Fax (713) 460-9499

www.customairproducts.com

SECTION

02

EVAPORATOR SELECTION

Performance	
Quantity	1
Volume (CFM)	13,500
External SP (in. wg)	4.25
Total SP (in. wg)	4.25
Operating Power (hp)	13.93
Start-Up Power (hp)	13.93
Fan RPM	1972
Max Fan RPM	2,178
Oper. Frequency (Hz)	60
Elevation (ft)	105
Start-up Temp.(F)	70
Operating Temp.(F)	70

Fan Configuration	
Size	24
Class	II
Arrangement	3
Rotation	CW
Orientation	Horizontal

Equipment Weights	
Fan (LMD)(lb)	301
Motor/Drive (lb)	277
Accessories (lb)	0

Misc Fan Data	
Outlet Velocity (ft/min)	2,954
Static Efficiency (%)	67
Tip Speed (ft/min)	12,649
Corner Weight A (lb)	145
Corner Weight B (lb)	109
Corner Weight C (lb)	185
Corner Weight D (lb)	139

Motor and Drives	
Motor Supplier	Greenheck
Size (hp)	15
RPM	1725
Enclosure	TEFC
Voltage	460
Cycle	60
Phase	3
Frame Size	254T
Max Frame Size	254
Location	Top
Pulley Type	Constant
Drive Loss (%)	3.4
NEC FLA* (Amps)	21

Model: 24-APH-3-II-150
Plenum Fan

Operating Performance

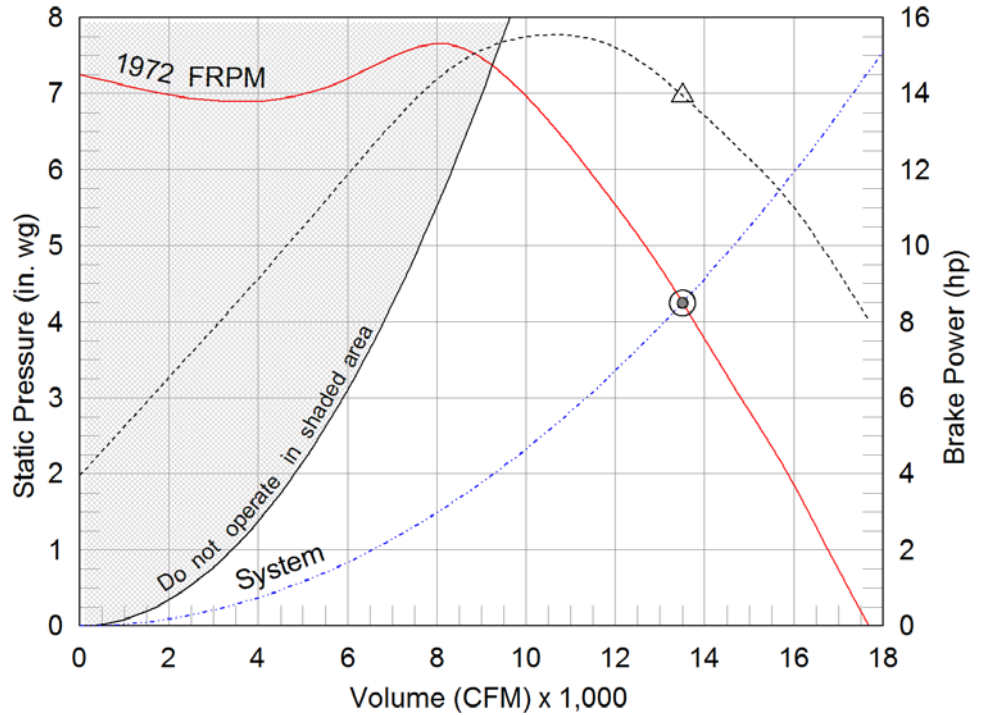

- △ Operating Bhp point
- Operating point at Total SP
- Operating point at External SP
- Fan curve
- - - System curve
- - - Brake horsepower curve



Sound Power by Octave Band

Sound Data	62.5	125	250	500	1000	2000	4000	8000	LwA	dBA	Sones
Inlet	83	86	91	95	87	84	79	75	95	83	37
Outlet	88	91	95	100	96	90	84	80	101	89	54

*FLA - based on tables 150 or 148 of National Electrical Code 2002. Actual motor FLA may vary, for sizing thermal overload, consult factory.

LwA - A weighted sound power level, based on ANSI S1.4

dBA - A weighted sound pressure level, based on 11.5 dB attenuation per octave band at 5 ft- dBA levels are not licensed by AMCA International

Sones - calculated using AMCA 301 at 5 ft

Model: 24-APH-3-II-150

Plenum Fan

Standard Construction Features:

HOUSING: Heavy gauge, welded steel mounting frame with die formed flanges - Inlet panel is heavy gauge steel with die formed flanges with welded corners - Steel components are phosphatized and coated - Corrosion resistant fasteners BEARINGS, SHAFT, AND WHEEL: Heavy duty, concentric locking, self-aligning ball or roller pillow block bearings - Polished, solid steel shafts - Welded, aluminum centrifugal wheel - 12 bladed construction- Airfoil blade profile

Selected Options & Accessories:

Motor PN - 302133, Baldor Motor Model Number - EM2333T
NEMA Premium Efficient Motor - meets NEMA Table 12-12
Motor with Minimum 40 Degree C Ambient Temperature
Motor with Class B Insulation
Fan Class - II
Motor Position - Top
Bearings - L(10) Life of 80,000 Hours, L(50) avg. life 400,000 Hours
Coating - Permatecor, Concrete Gray-RAL 7023, Fan and Attached Accessories, Mill Finish on Aluminum Wheel
Fan Orientation - Horizontal
Factory Vibration Test, 0.15 in/sec, peak, filter-in as measured at the fan RPM
Motor Slide Base
Unit Warranty: 1 Yr (Standard)

Model: 24-APH-3-II-150

Plenum Fan

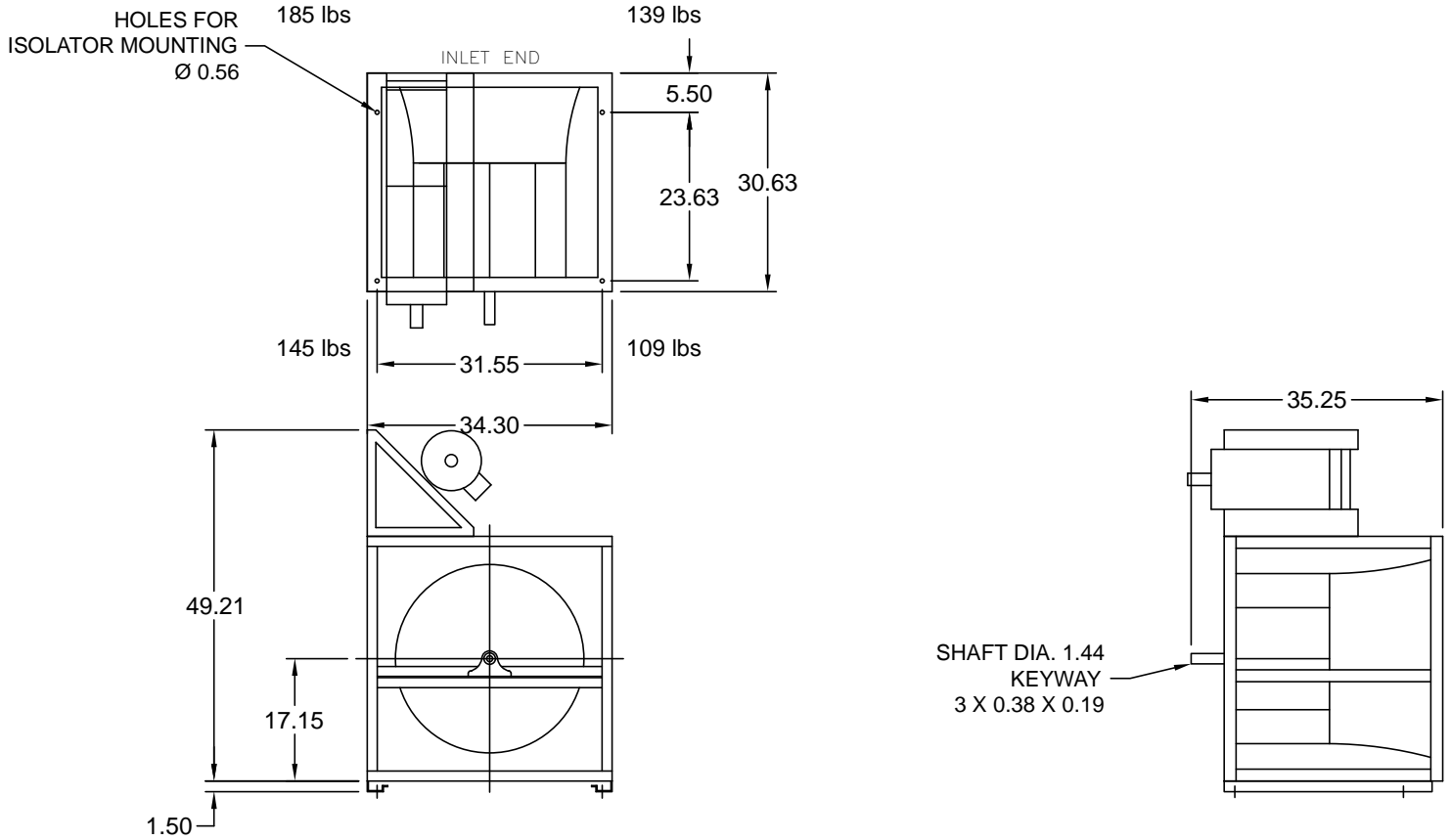

Notes: All dimensions shown are in units of in.
Drawings are not to scale. Drawings are of standard unit and do not include dimensions for accessories or design modifications.



Information

Project: Compact - 40 Ton	Coil Name: Evap Coil - 45 SST	Coil ID: 46069
Date: 1/17/2017 6:24:56 PM	Model #: DXG06C09-50.00x77.00R	Quote No: 015656-002

Physical Data

Coils/Bank: 1
 Fin Type: 1/2" 1.25" x 1.083" Waffle
 Fin Height: 50"
 Fin Length: 77"
 Rows: 6
 Fins/Inch: 9
 # Feeds: 20
 Dry Weight (ea.): 363 Lbs.

Materials

Fin Matl: Aluminum 0.0075 in.
 Tube Matl: Copper 0.016 in.

Internal Fluid

Refrigerant: R410a
 Liquid Temp: 109.8 °F
 Evap. Temp: 45
 Lvg. Super Heat: 20

Airside

Airflow: 13500 SCFM
 Altitude: 0 ft.
 Ent. DB/WB: 79.8 °F / 66.5 °F
 Capacity Req'd: 494 MBH

Construction

Coil Style: Interlaced2Circ
 Coil Hand: Right
 Casing Matl: 16 Ga Galv Steel
 Casing Type: Flanged
 Connection Matl: Copper
 Connection Type: SWT

Performance

Description	UOM	Evaporator Perf.
Model		DXG06C09-50.00x77.00R
Rows/FPI		6 / 9
Total Capacity	MBH	498
Sensible Capacity	MBH	369
Lvg Air DB/WB	°F	54.9/54.4
Face Velocity	SFPM	504.94
Refrigerant Charge	lbs	17.43
Air Pressure Drop	in wc	0.48
Ref Pressure Drop	psi	8.63
Total Feeds		20
Tube Vapor Velocity	FPM	2,049
Suction Conn		1.375
Suction Line Velocity	FPM	3,123
Distributor #1	Model	706-10-5/16-20
Distributor #2	Model	706-10-5/16-20
Dry Weight (ea.)	Lbs	363

Special Notes:

Coil is NOT certified by AHRI.



CUSTOM AIR PRODUCTS & SERVICES, INC.

35 Southbelt Industrial Drive • Houston, Texas 77047

(713) 460-9009 • Fax (713) 460-9499

www.customairproducts.com

SECTION

03

CONDENSER SELECTION



Information

Project: Compact - 40 Ton - Copy	Coil Name: Cond Coil - LH	Coil ID: 46067
Date: 1/17/2017 6:24:55 PM	Model #: CDK04C12-36.00x100.00L	Quote No: 015656-002

Physical Data

Coils/Bank: 1
 Fin Type: 3/8" 1.00" x 0.866" Louver
 Fin Height: 36"
 Fin Length: 100"
 Rows: 4
 Fins/Inch: 12
 # Feeds: 18
 Dry Weight (ea.): 216 Lbs.

Materials

Fin Matl: Aluminum 0.0075 in.
 Tube Matl: Copper 0.014 in. Rifled

Internal Fluid

Refrigerant: R410a
 Cond. Temp: 125 °F
 Sub Cooling: 15
 Super Heat: 20

Airside

Airflow: 15000 SCFM
 Altitude: 0 ft.
 Ent. DB: 95 °F
 Capacity Req'd: 371 MBH

Construction

Coil Hand: Left
 Casing Matl: 16 Ga Galv Steel
 Casing Type: Inverted
 Connection Matl: Copper
 Connection Type: SWT

Performance

Description	UOM	Condenser Perf.
Model		CDK04C12-36.00x100.00L
Rows/FPI		4 / 12
Total Capacity	MBH	374
Sensible Capacity	MBH	374
Lvg Air DB	°F	118.1
Face Velocity	SFPM	600
Refrigerant Charge	lbs	25.49
Air Pressure Drop	in wc	0.61
Ref Pressure Drop	psi	7.22
Sub Cooling		15.76
Total Feeds		Optimized at 18 Feeds
Inlet Connection		1.125"
Outlet Connection		0.875"
Dry Weight (ea.)	Lbs	216

Special Notes:

Coil is outside the scope of AHRI Standard 410.



Information

Project: Compact - 40 Ton	Coil Name: Cond Coil - RH	Coil ID: 46068
Date: 1/17/2017 6:24:56 PM	Model #: CDK04C12-36.00x100.00R	Quote No: 015656-002

Physical Data

Coils/Bank: 1
 Fin Type: 3/8" 1.00" x 0.866" Louver
 Fin Height: 36"
 Fin Length: 100"
 Rows: 4
 Fins/Inch: 12
 # Feeds: 18
 Dry Weight (ea.): 216 Lbs.

Materials

Fin Matl: Aluminum 0.0075 in.
 Tube Matl: Copper 0.014 in. Rifled

Internal Fluid

Refrigerant: R410a
 Cond. Temp: 125 °F
 Sub Cooling: 15
 Super Heat: 20

Airside

Airflow: 15000 SCFM
 Altitude: 0 ft.
 Ent. DB: 95 °F
 Capacity Req'd: 371 MBH

Construction

Coil Hand: Right
 Casing Matl: 16 Ga Galv Steel
 Casing Type: Inverted
 Connection Matl: Copper
 Connection Type: SWT

Performance

Description	UOM	Condenser Perf.
Model		CDK04C12-36.00x100.00R
Rows/FPI		4 / 12
Total Capacity	MBH	374
Sensible Capacity	MBH	374
Lvg Air DB	°F	118.1
Face Velocity	SFPM	600
Refrigerant Charge	lbs	25.49
Air Pressure Drop	in wc	0.61
Ref Pressure Drop	psi	7.22
Sub Cooling		15.76
Total Feeds		Optimized at 18 Feeds
Inlet Connection		1.125"
Outlet Connection		0.875"
Dry Weight (ea.)	Lbs	216

Special Notes:

Coil is outside the scope of AHRI Standard 410.

Three Phase VariTough® Inverter Duty Commercial Condenser Fan, Open Dripproof, Air Over



APPLICATIONS:

For use on condenser cooling fans in commercial air conditioning applications, where 3 phase power and variable frequency drives (VFD's) are required.

FEATURES:

- Inverter Duty
- Designed to NEMA[†] MG1-Part 31
- Open Dripproof, Shaft-Up Design
- 70°C Ambient
- Continuous Duty, Air Over
- Lock Bearing System OSE
- Class F Insulation
- Thermostat Temperature Protection
- Use Kit 21 for Shaft Grounding Option
- **Discount Symbol: DS-3HAC**

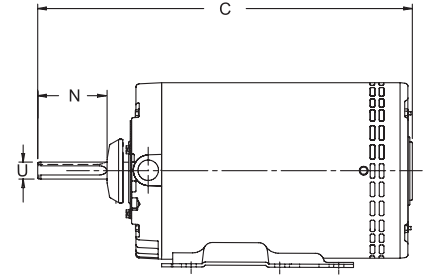

Belly Band Mount

HP	RPM	Voltage	Catalog Number	NEMA [†] Frame	Amps	Shaft N	Shaft U	Total C	Ship Wt. (lbs)
1	825	208-230/460	1830V	56YZ	5.2-5.2/2.6	3.25	0.625	15.8	33
	850	208-230/460	1828V	56YZ	5.0-5.0/2.5	6.0	0.625	16.8	42
	1140	208-230/460	1818V	56YZ	4.3-4.3/2.1	6.0	0.625	15.8	33
1 1/2	850	208-230/460	1832V	56HZ	6.6-6.2/3.1	3.5	0.625	15.8	37
	1140	208-230/460	1819V	56YZ	5.3-5.3/2.6	6.0	0.625	16.3	40
2	1140	208-230/460	8987V	56YZ	7.8-7.8/3.9	6.0	0.625	17.3	43

Rigid Base Mount

HP	RPM	Voltage	Catalog Number	NEMA [†] Frame	Amps	Shaft N	Shaft U	Total C	Ship Wt. (lbs)
1	850	208-230/460	1833V	56YZ	5.0-5.0/2.5	6.0	0.625	16.8	38
	1140	208-230/460	1820V	56YZ	4.3-4.3/2.1	6.0	0.625	15.8	34
1 1/2	850	208-230/460	1831V	56HZ	6.6-6.2/3.1	3.5	0.625	15.8	40
	1140	208-230/460	1821V	56YZ	5.3-5.3/2.6	6.0	0.625	16.3	41
2	1140	208-230/460	1822V	56YZ	7.8-7.8/3.9	6.0	0.625	17.3	44

For shaft grounding kit, order kit 21. See pages 188-189.

[†] All marks shown within this document are properties of their respective owners.



REV H

TERMINAL COVER
GASKET

NAMEPLATE

WARNING LABEL

LABEL

.19 KEY
4.875 LONG

1 FLAT
.06 DEEP
4.875 LONG

WATER
SLINGER

LEAD END

GREEN GROUND SCREW
SIZE 1/2 CONDUIT
WITH CONDUIT PLUG

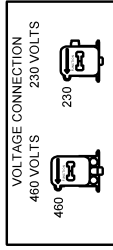

ROTATION: CW LE REV.
WHEN PHASED AS SHOWN.
L1 -- PHASE A
L2 -- PHASE B
L3 -- PHASE C

ENCLOSED ENDSHIELD
THERMOSTAT LEADS TO EXTEND
4.0 + 2.0 INCHES BEYOND TERMINAL
OPENING IN ENDSHIELD.

6.50

TERMINAL COVER
GASKET

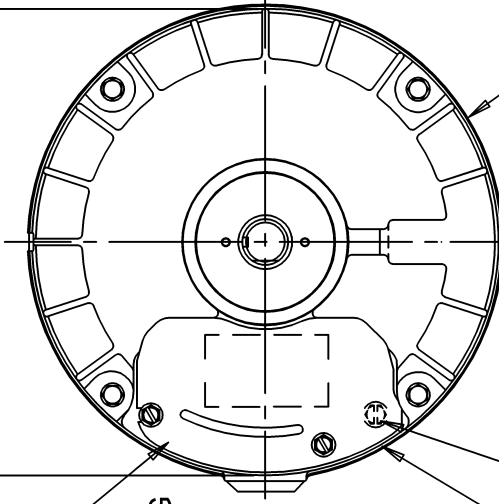

GREEN GROUND
SCREW

ENCLOSED ENDSHIELD

THERMOSTAT LEADS TO EXTEND
4.0 + 2.0 INCHES BEYOND TERMINAL
OPENING IN ENDSHIELD.

INVERTER DUTY-NEMA 31

MODEL		REF	CUSTOMER	HP	VOLTS	AMPS	HZ	RPM	ROTATION	CUSTOMER PN
J63WZBK-B-0191			WHOLESALE-HAC	2.0	208-230/460	7.8-7.8/3.9	60	1140	REVERSIBLE	8987V
SHEET NUMBER	REV	REVISION RECORD FOR: D1618-00								
1 OF 1	H	INFORMATION DISCLOSED ON THIS DOCUMENT IS CONSIDERED PROPRIETARY AND SHALL NOT BE REPRODUCED OR DISCLOSED WITHOUT WRITTEN CONSENT OF NIDEC MOTOR CORPORATION								
REVISION DATE	ALL DIMENSIONS ARE FOR REFERENCE ONLY UNLESS TOLERANCE IS GIVEN									
28-JUL-14	TITLE									
ISSUED BY	I. DE LEON		REVIEWED BY		M. GUZMAN		ENGINEER APPROVED		B. GAITAN	
ASSEMBLED VIEW		CODE		V01		ITEM NO.		775495		SIZE
ASSEMBLED VIEW		V01		775495		A		SOLIDEDGE		

D04 CONN POINT	CONNECTION COMBINATION
01	FN-1b
02	FN-2b
03	FN-3b
04	ST-1b
05	ST-2b
06	ST-3b
07	FN-1a
08	FN-2a
09	FN-3a
10	ST-1a ST-2a ST-3a

INPUT VOLTAGE	L1	L2	L3	JOIN CONN. POINTS
LOW	(1,7)	(2,8)	(3,9)	(4,5,6)
HIGH	(1)	(2)	(3)	(4,7) (5,8) (6,9)

COIL END SLEEVING

COIL END SLEEVING WHEN REQUIRED

NOTE:

1). INPUT POWER (PHASED A,B,C) CONNECTED AS STATED PRODUCES CWLE ROTATION. TO REVERSE DIRECTION, INTERCHANGE L2& L3.

COIL END SLEEVING WHEN REQUIRED

THERMOSTAT LEADS

COIL END SLEEVING

COIL END SLEEVING

COIL END SLEEVING WHEN REQUIRED

REV A

REVISION DESCRIPTION FOR: C8396-14	SCALE	UNITS	TITLE		NIDEC MOTOR CORPORATION
UPDATED BACKGROUND TO NIDEC	NONE	IN	DIAGRAM OF CONNECTIONS		
MATERIAL:	TOLERANCES ON DIMENSIONS (UNLESS OTHERWISE SPECIFIED)		ISSUED BY	APPROVED BY	REVISION DATE
MUST BE COMPLIANT TO RoHS DIRECTIVE EU 2002/95/EC AND REGULATION EC 1907/2006 (REACH) AS AMENDED	INCHES	mm	A. SANCHEZ	J.I. SALAZAR	23-SEP-13
	.015		CODE	DWG NO.	REV
	ANGLES X°= ±1°		D04	775062	A
					SHEET NUMBER
					1 OF 1
					DWG SIZE
					A

NIDEC CONFIDENTIAL
NIDEC MOTOR CORPORATION 23-Sep-13
NMCA (MAR-2011)

SOLIDEDGE



Job Name					Submitted by/notes					
Model MODEL F15E08-3026	Flow 10000 CFM	Pressure (Ps) 0.75 in-wg	Temperature 70 °F	Altitude 0 ft	Density 0.075 lb/ft³	Q Derate 0 cfm	P Derate 0.00 in-wg	VAV Set Point 0.00 in-wg	Date 01-12-2016	
Fan Tag	Flow 9796 CFM	Pressure (Ps) 0.72 in-wg	Power 1.97 hp	Static Efficiency 56.5 %	Total Efficiency 74.7 %	Speed 1140 rpm	Outlet Velocity 1931 fpm	Efficiency Rating		
	Impeller Dia 30.0 in	Outlet Area 5.07 ft²	Max Speed 1200 rpm	Pitch 26 deg	Drive Direct Drive	Blades 4	P Volume 1.8 ft³	Turndown 100 %		

Performance

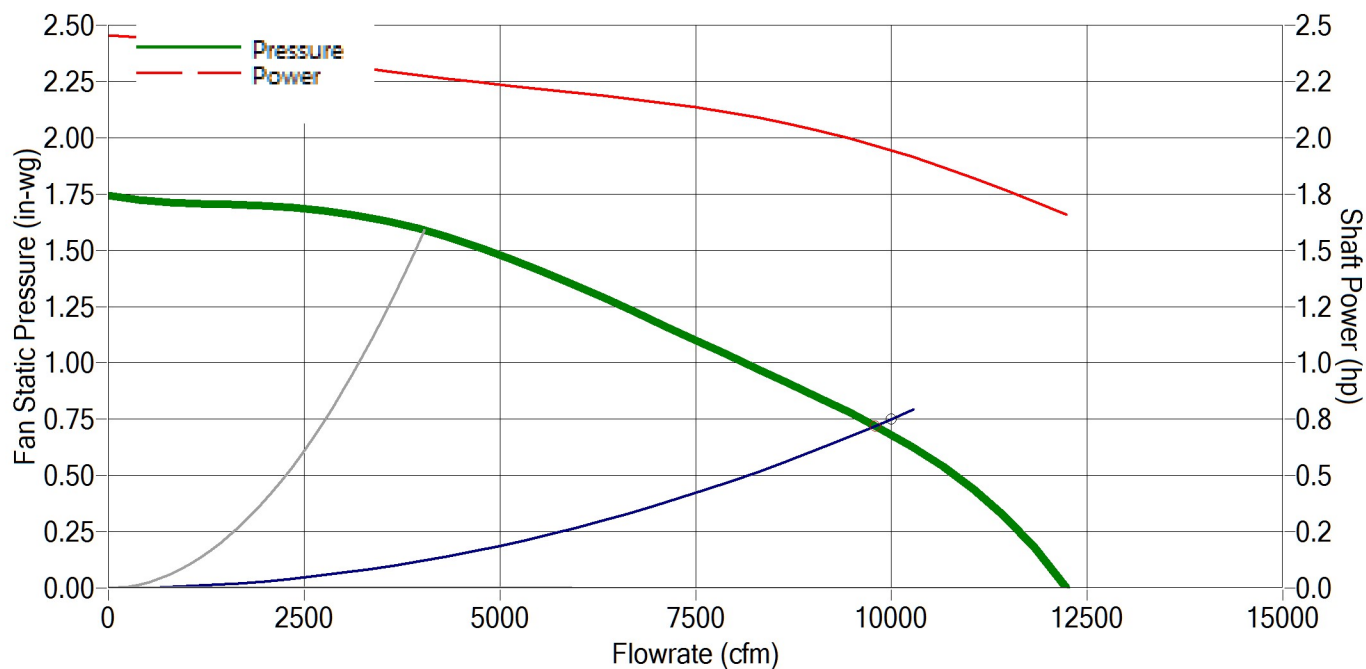

Sound	63	125	250	500	1000	2000	4000	8000	Lw	LwA
	N/A	N/A	N/A	N/A	N/A	N/A	N/A	N/A	N/A	N/A

Options

- Available Bore: 1/2, 5/8, 3/4 and 7/8 inch
- Keyway: Available in bore sizes 1/2 inch or larger
- Blade Material: Aluminum
- Spider Material: Painted Steel, Galvanized Steel
- Hub Location: Discharge side, Inlet side
- Set Screw Quantity: 1 or 2
- Rotation: Determine rotation by viewing discharge side of prop
Clockwise or counterclockwise

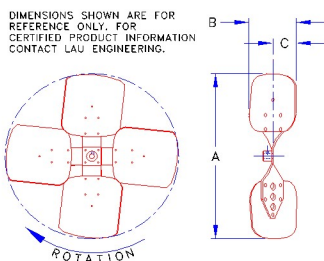

DIMENSIONS SHOWN ARE FOR REFERENCE ONLY. FOR CERTIFIED PRODUCT INFORMATION CONTACT LAU ENGINEERING.

A	B	C
30.00	4.29	1.85

Dimensions in inches

Notes: Airflow performance data are obtained in accordance with AMCA 210-07. Installed performance will vary depending on extent of cabinet geometry



CUSTOM AIR PRODUCTS & SERVICES, INC.

35 Southbelt Industrial Drive • Houston, Texas 77047

(713) 460-9009 • Fax (713) 460-9499

www.customairproducts.com

SECTION

04

COMPRESSOR SELECTION



BITZER Output data

Created on : 12.12.2017 21:36:31



20 TON COMPRESSOR
40 TON COMPACT UNIT

BITZER Software v6.7.0 rev1879

12.12.2017 / All data subject to change.

2 / 6

Table of content

Project survey.....	3
Selection: Scroll-Compressor.....	4
Technical Data: GSD60235VA.....	5
Information: Scroll-Compressor.....	6



20 TON COMPRESSOR
40 TON COMPACT UNIT

BITZER Software v6.7.0 rev1879

12.12.2017 / All data subject to change.

3 / 6

Project survey

Selected compressors

Scroll-Compressor

1x GSD60235VA



**20 TON COMPRESSOR
40 TON COMPACT UNIT**

BITZER Software v6.7.0 rev1879

12.12.2017 / All data subject to change.

4 / 6

Selection: Scroll-Compressor

Input Values

Compressor model	GSD60235VA
Refrigerant	R410A
Reference temperature	Dew point temp.
Evaporating SST	45,0 °F
Condensing SDT	125,0 °F
Liq. subc. (in condenser)	15,00 °F
Suct. gas superheat	20,00 °F
Power supply	460V-3-60Hz UL
Useful superheat	100%

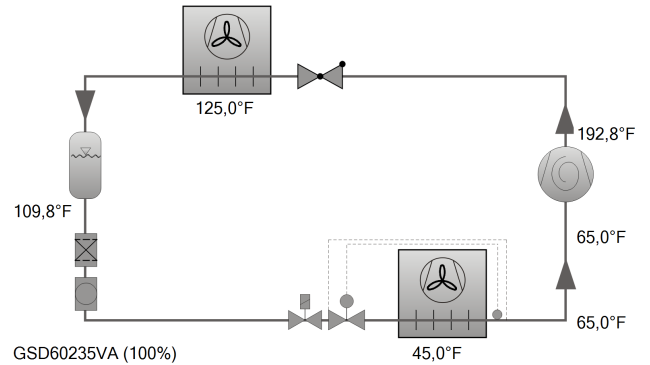

Result

Compressor	GSD60235VA_4
Capacity steps	100%
Cooling capacity	244 kBtu/h
Cooling capacity *	244 kBtu/h
Evaporator capacity	244 kBtu/h
Power input	19,81 kW
Current (460V)	27,6 A
Voltage range	460V
Condenser Capacity	312 kBtu/h
COP/EER	12,32
COP/EER *	12,32
Mass flow	3475 lb/h
Discharge gas temp. w/o cooling	192,8 °F

Tentative Data.
according to ARI540 (20°F suction gas superheat, 15°F liquid subcooling)

Application Limits

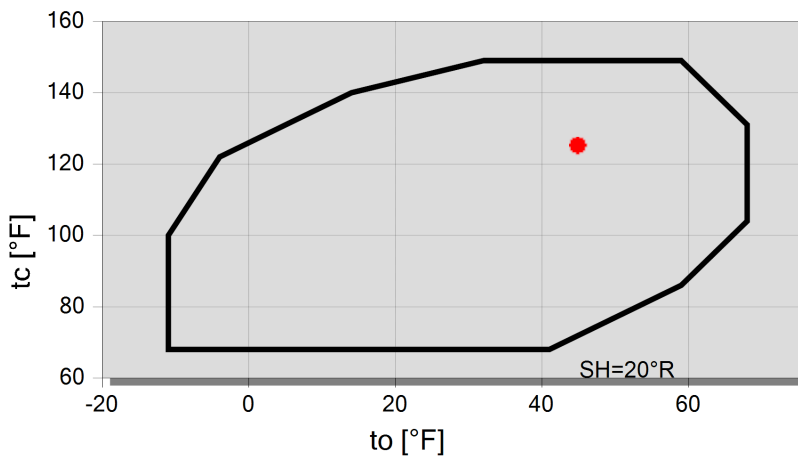

Legend
● A



Scroll-Compressor

Legend of connection positions according to "Dimensions":

ESH/ELH/ELA:

- 1 High pressure measurement connection (HP) - Schrader
 - 2 High pressure connection (HP) alternatively: connection for discharge gas temperature sensor
 - 3 Low pressure connection (LP)
 - 4 Sight glass
 - 5 Oil maintenance connection
 - 6 Connection for oil and gas equalization (parallel operation)
 - SL Suction line
 - DL Discharge line
- Dimensions can show tolerances according to EN ISO 13920-B.

GSD:

- 1 -
 - 2 High pressure connection (HP) alternatively: connection for discharge gas temperature sensor
 - 3 -
 - 4 Sight glass
 - 5 Oil maintenance connection
 - 6 Connection for oil and gas equalization (parallel operation)
 - 7 Mounting position for vibration dampers
 - 8 Mounting position for Tandem and Trio fixing rails
 - SL Suction gas line
 - DL Discharge gas line
- Dimensions can show tolerances according to EN ISO 13920-B.

GSD Rotalock:

- 1 High pressure measurement connection (HP) - Schrader
 - 2 High pressure connection (HP) alternatively: connection for discharge gas temperature sensor
 - 3 Low pressure connection (LP)
 - 4 Sight glass
 - 5 Oil maintenance connection
 - 6 Connection for oil and gas equalization (parallel operation)
 - 7 Mounting position for vibration dampers
 - 8 Mounting position for Tandem and Trio fixing rails
 - SL Suction gas line
 - DL Discharge gas line
- Dimensions can show tolerances according to EN ISO 13920-B.



CUSTOM AIR PRODUCTS & SERVICES, INC.

35 Southbelt Industrial Drive • Houston, Texas 77047

(713) 460-9009 • Fax (713) 460-9499

www.customairproducts.com

SECTION

05

HEATER SELECTION



CUSTOM AIR PRODUCTS & SERVICES, INC.

35 Southbelt Industrial Drive • Houston, Texas 77047

(713) 460-9009 • Fax (713) 460-9499

www.customairproducts.com

SECTION

06

MISC. COMPONENTS



VT7600 Series Programmable & Non-Programmable Thermostats For Commercial HVAC Applications

(Issue Date June 17, 2008 – 028-0132 R8)

Product overview

The VT7600 PI thermostat family is specifically designed for single stage and multi-stage control of heating/cooling equipment such as rooftop and self-contained units. The product features an intuitive, menu-driven, back-lit LCD display which walks users through the programming steps, making the process extremely simple. Accurate temperature control is achieved due to the product's PI time proportional control algorithm, which virtually eliminates temperature offset associated with traditional, differential-based thermostats.

All models contain two digital inputs, which can be set by the user to monitor filter status, activate a remote temporary occupancy switch, and/or used as a general purpose service indicator. In addition, depending on the model, up to three remote sensor inputs are available. All models contain a SPST auxiliary switch, which can be used to control lighting or disable the economizer function and a discharge air sensor input. For more advanced applications, an economizer control logic has been integrated onto the thermostat for use with proportional damper economizer actuators.



Fig.1 - VT7600 Series

The additional following documentation is available on www.viconics.com

- Information on the LON models (VT76xxX1000E), is available on document ITG-VT7600-LON-Exx
- Information on the BACnet models (VT76xxX1000B), is available on document ITG-VT7600-BAC-Exx
- Information on the Wireless models (VT76xx0X1000W), is available on documents: ITG-VWG-40-BAC-Exx and LIT-VWG-40-SETUP-Exx

Models available

Application	1 Heat / 1 Cool	2 Heat / 2 Cool	2 Heat / 2 Cool with economizer	3 Heat / 2 Cool heat pump
Model (programmable)	VT7652A1000	VT7652B1000	VT7656B1000	VT7652H1000
Model (non-programmable)	VT7600A1000	VT7600B1000	VT7605B1000	VT7600H1000

Features and benefits

Features	Benefits
• PI time proportioning algorithm	⇒ Increased comfort , accuracy, and energy savings
• 2 digital inputs	⇒ Adds functionality
• Smart fan	⇒ Saves energy during night mode
• Unique configuration key	⇒ Minimizes parameter tampering
• Lockable keypad	⇒ Tamper proof, no need for thermostat guards
• Freeze protection	⇒ Prevents costly freeze damage
• EEPROM memory	⇒ No loss of program
• 6 hour reserve time for clock	⇒ No need to reprogram day/time after power shortage
• Remote room and outdoor temperature sensor	⇒ Increase flexibility and functionality
• Auxiliary output	⇒ Can be used for lighting and/or economizer override
• Discharge air sensor	⇒ Can be used to monitor unit efficiency
• Intuitive, menu-driven programming (7 day, 2/4 events - on programmable models only)	⇒ Can be used for all types of establishments
• Economizer output (0-10 V d.c.) (on economizer models only)	⇒ Excellent retrofit opportunities
• Low/High balance point (on heat pump models only)	⇒ Protect and optimize systems performances
• 3 Heat/2 Cool (on heat pump models only)	⇒ Support single and two stages heat pump with one auxiliary heat stage

Theory of operation

The VT7600 uses a Viconics proprietary adaptive logic algorithm to control the space temperature. This algorithm controls the heating / air conditioning system to minimize overshoot while still providing comfort. It provides exceptional accuracy due to its unique PI time proportioning control algorithm, which virtually eliminates temperature offset associated with traditional, differential-based on/off thermostats.

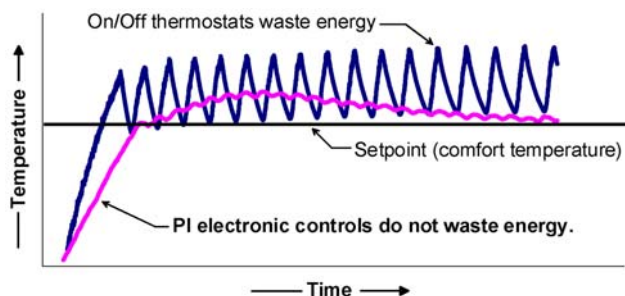

Fig.2 - On/Off mechanical control vs PI electronic control.

Features overview

- 7 day programmable models, 2 or 4 events
- Gas/oil or electric system compatibility for all type of applications
- Remote indoor averaging sensing capability
- Temperature averaging with 2, 3, 4, 9 or 16 sensors
- Remote outdoor sensing capability for added flexibility
 - System mode lock out
 - Heat pump balance point settings
- Remote discharge air sensor input for monitoring purpose
 - System efficiency feedback
- Lockable keypads for tamper proofing. No need for thermostat guards
- Automatic frost protection to prevents costly freeze damage
- Anti short cycle and minimum on/off run time protection. Reduces wear and maximizes life span of mechanical equipment.
- 2 programmable digital inputs for added flexibility. Each input can be programmed as the following:
 - **None:** No function will be associated with the input
 - **Service:** a backlit flashing **Service** alarm will be displayed on the thermostat LCD screen when the input is energized. It can be tied in to the AC unit control card, which provides an alarm in case of malfunction.

- **Filter:** a backlit flashing **Filter** alarm will be displayed on the thermostat LCD screen when the input is energized. It can be tied to a differential pressure switch that monitor filters
- **Rem NSB:** remote NSB timer clock input. Will disable the internal scheduling of the thermostat. The scheduling will now be set as per the digital input. The menu part related to scheduling is disabled and no longer accessible. It provides low cost setback operation via occupancy sensor or from a dry contact
- **RemOVR:** temporary occupancy contact. Disables all override menu function of the thermostat. . The override function is now controlled by a manual remote momentarily closed contact. When configured in this mode, the input operates in a toggle mode.

With this function enabled it is now possible to toggle between unoccupied & occupied setpoints for the amount of time set by parameter (TOccTime) temporary occupancy time.

- Programmable smart fan operation saves energy during night mode
- Non volatile EEPROM memory prevents loss of parameters during power shortage
- Built in default profile set-up for easier start up and commissioning
- Configurable SPST output relay on programmable models for lighting, exhaust fan or fresh air control
- 6 hour typical reserve time for clock in case of power loss
- 0 to 10 Vdc economizer output for more retrofit opportunities
 - Built in dry bulb economizer logic using outdoor temperature sensor
 - Input for supply/mixed air temperature sensor

Heat pump model specific features

- Selectable single or dual stage compressor stages
- High balance point: Locks out auxiliary heating when outside air temperature is above this value
- Low balance point: Locks out heat pump compressor operation when outside air temperature is below this value
- Comfort/economy mode: In economy mode, heat pump use is maximized before turning On auxiliary heating
- Compressor/auxiliary interlock: Adds flexibility by locking out heat pump operation during auxiliary heating to prevent high pressure trip when the coil is downstream of the auxiliary heat source.

Installation

- Remove security screw on the bottom of thermostat cover.
- Open up by pulling on the bottom side of thermostat.
- Remove Assembly and remove wiring terminals from sticker. **(Fig. 3)**
- Please note the FCC ID and IC label installed in the cover upon removal of cover for the wireless products.

A) Location:

- 1- Should not be installed on an outside wall.
- 2- Must be installed away from any heat source.
- 3- Should not be installed near an air discharge grill.
- 4- Should not be affected by direct sun radiation.
- 5- Nothing must restrain vertical air circulation to the thermostat.

B) Installation:

- 1- Swing open the thermostat PCB to the left by pressing the PCB locking tabs. **(Fig. 4)**
- 2- Pull out cables 6" out of the wall.
- 3- Wall surface must be flat and clean.
- 4- Insert cable in the central hole of the base.
- 5- Align the base and mark the location of the two mounting holes on the wall. Install proper side of base up.
- 6- Install anchors in the wall.
- 7- Insert screws in mounting holes on each side of the base. **(Fig. 4)**
- 8- Gently swing back the circuit board on the base and push on it until the tabs lock it.
- 10- Strip each wire 1/4 inch.
- 11- Insert each wire according to wiring diagram.
- 13- Gently push back into hole excess wiring **(Fig. 5)**
- 14- Re-Install wiring terminals in correct location. **(Fig. 5)**
- 15- Reinstall the cover (top side first) and gently push back extra wire length into the hole in the wall.
- 16- Install security screw.

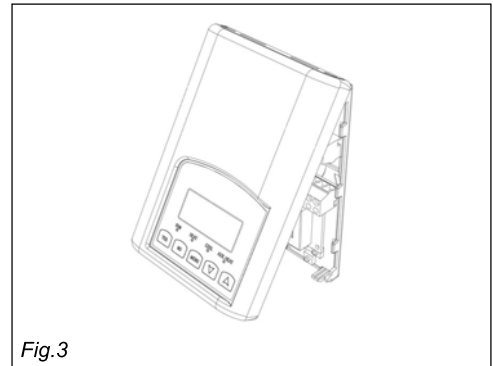

Fig.3

Location of PCB retaining tabs

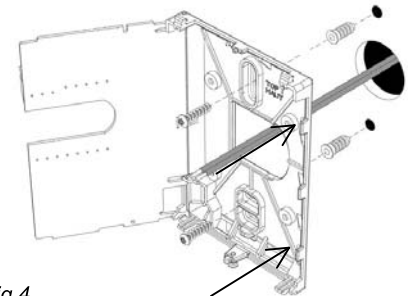

Fig.4

Re-install terminal blocks

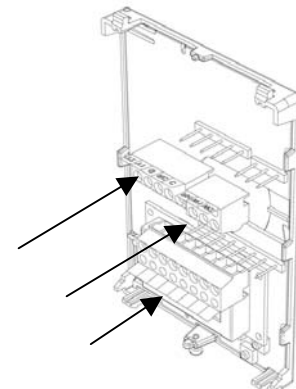

Fig.5

Thermostat assembly (VT7300F 1000 shown)



Fig.6



- If replacing an old thermostat, label the wires before removal of the old thermostat.
- Electronic controls are static sensitive devices. Discharge yourself properly before manipulation and installing the thermostat.
- Short circuit or wrong wiring may permanently damage the thermostat or the equipment.
- Anti-short cycling can be set to 0 minutes for equipment that posses their own anti cycling timer. Do not use that value unless the equipment is equipped with such internal timer. Failure to do so can damage the equipment.
- All VT7600 series thermostats are to be used only as operating controls. Whenever a control failure could lead to personal injury and/or loss of property, it becomes the responsibility of the user to add safety devices and/or alarm system to protect against such catastrophic failures.

Wiring

Terminal identification

Part Number	Multistage				1H / 1C		Part Number	Heat Pump	
	VT7656B	VT7605B	VT7652B	VT7600B	VT7652A	VT7600A		VT7652H	VT7600H
Programmable	Yes	No	Yes	No	Yes	No	Programmable	Yes	No
Top left terminal block							Top left terminal block		
Y2	X	X	X	X			Y2	X	X
Y1	X	X	X	X	X	X	Y1	X	X
G	X	X	X	X	X	X	G	X	X
RC	X	X	X	X	X	X	RC	X	X
C	X	X	X	X	X	X	C	X	X
Top right terminal block							Top right terminal block		
RH	X	X	X	X	X	X	RH	X	X
W1	X	X	X	X	X	X	W1	X	X
W2	X	X	X	X			O/B	X	X
Bottom terminal block							Bottom terminal block		
Econo	X	X							
Aux	X	X	X	X	X	X	Aux	X	X
DI1	X	X	X	X	X	X	DI1	X	X
DI2	X	X	X	X	X	X	DI2	X	X
RS	X	X	X	X	X	X	RS	X	X
Scom	X	X	X	X	X	X	Scom	X	X
OS	X	X	X	X	X	X	OS	X	X
MS	X	X	X	X	X	X	MS	X	X

Screw terminal arrangement

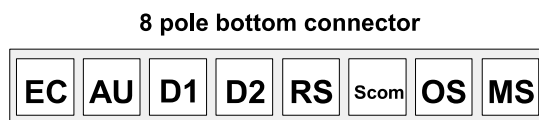
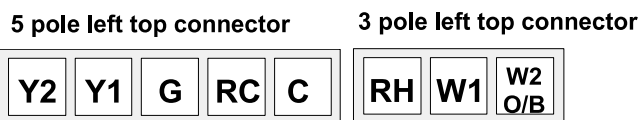

Wiring notes:

- Note 1: If the same power source is used for the heating stages, install jumper across RC & RH. Maximum current is 2.0 amps.
- Note 2: If auxiliary output is used to toggle occupancy of the electronic control card inside the equipment, configure the relay parameter (Aux cont) to the N.O. setting. A second relay can be added for additional functionality of the occupancy output.
- Note 3: Economizer output uses a half bridge rectifier. Reference of the control signal is the common of the power supply of the thermostat. (terminal C)
- Note 4: Electromechanical contacts are to be used with the digital inputs. Electronic triacs cannot be used as mean of switching for the input. The switched leg to the input for the input to activate is terminal C (common)
- Note 5: The transformer of the unit provides power to the thermostat and the additional loads that will be wired to the thermostat.

Detailed wiring diagrams for selected models

VT7656B1000
2 Heat / 2 Cool / Economizer / Programmable

Thermostat Terminals -VT7656B1000

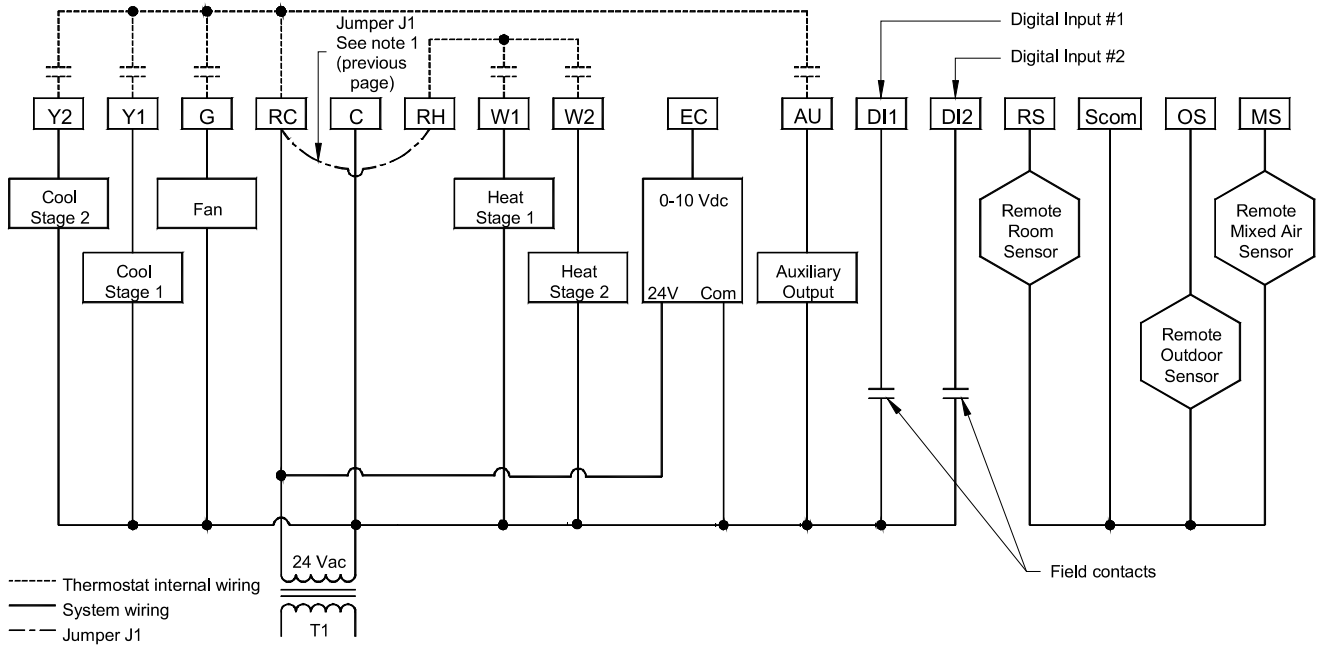
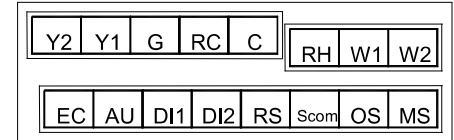

VT7652H1000
Heat pump / Programmable

Thermostat Terminals - VT7652H1000

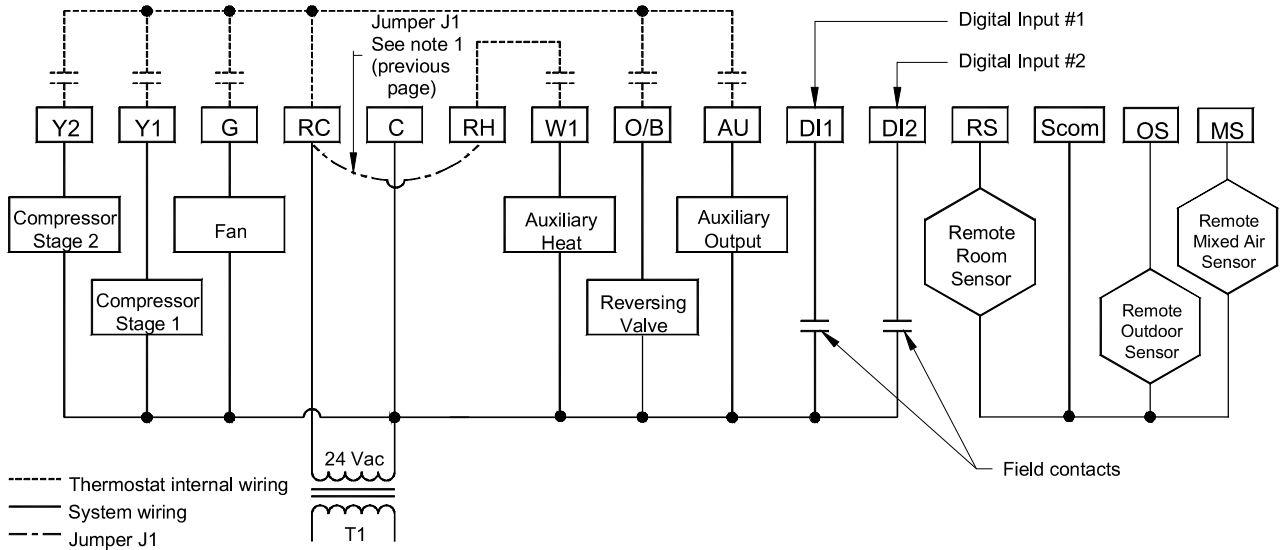
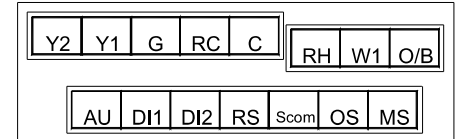

Remote sensor accessories

Model no.	Description
S3010W1000	Wall mounted temperature sensor
S3020W1000	Wall mounted temperature sensor with override button and occupancy status LED
S2020E1000	Outdoor temperature sensor
S2060A1000	Averaging temperature sensor
S2000D1000	Duct mounted temperature sensor



Fig.8 – S3020W1000 wall mounted sensor

Remote mount temperature sensors use 10K NTC thermistors.

- This sensor can be used for:
- 3 thermistors with 2 dip switches are provided with each sensor for various averaging combinations
- Optional occupancy led
- Optional override key

Wiring example of single remote room sensor:

VT7600 Series Thermostat 1x S3020W1000 Remote wiring 1 sensor S2-1 = ON / S2-2 = ON

S3010W1000 Remote wiring 1 sensor S2-1 = ON / S2-2 = ON

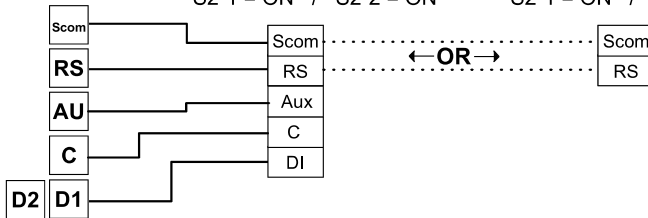

Dip switch setting for: **1 sensor**

ON S2-1 = ON
OFF S2-2 = ON

Wiring examples of 2 remote room sensors for averaging applications:

VT7600 Series Thermostat 2x S3020W1000 Remote wiring 2 sensors S2-1 = OFF / S2-2 = ON

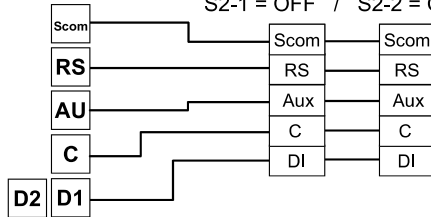

VT7600 Series Thermostat 2x S3010W1000 Remote wiring 2 sensors S2-1 = OFF / S2-2 = ON

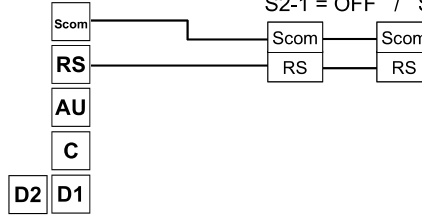

VT7600 Series Thermostat 1x S3010W1000 and 1x S3020W1000 Remote wiring 2 sensors S2-1 = OFF / S2-2 = ON

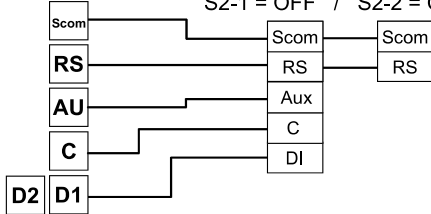

Notes for averaging applications:

- S3010W1000 and S3020W1000 can be mixed matched.
- S3010W1000 and S3020W1000 are to be wired in parallel.
- Respect the dip switch setting in each remote sensor.

Dip switch setting for: **2 sensors**

ON S2-1 = OFF
OFF S2-2 = ON

Wiring examples of 3 remote room sensors for averaging applications:

VT7600 Series Thermostat 2x S3010W1000 and 1x S3020W1000 Remote wiring 3 sensors S2-1 = OFF / S2-2 = OFF

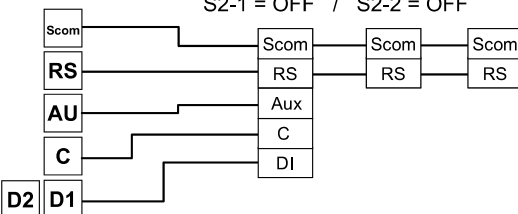

VT7600 Series Thermostat 1x S3010W1000 and 2x S3020W1000 Remote wiring 3 sensors S2-1 = OFF / S2-2 = OFF

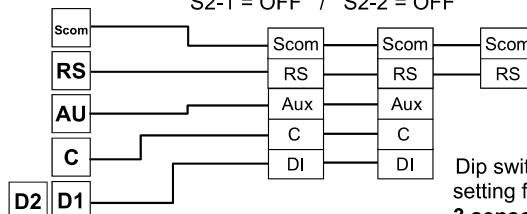

Dip switch setting for: **3 sensors**

ON S2-1 = OFF
OFF S2-2 = OFF

Temperature vs resistance chart for 10 Kohm NTC thermistor

($R_{25^{\circ}\text{C}} = 10\text{K}\Omega \pm 3\%$ - $B_{25/85^{\circ}\text{C}} = 3975\text{K} \pm 1.5\%$)

°C	°F	Kohm	°C	°F	Kohm	°C	°F	Kohm	°C	°F	Kohm	°C	°F	Kohm
-40	-40	324.3197	-20	-4	94.5149	0	32	32.1910	20	68	12.4601	40	104	5.3467
-39	-38	303.6427	-19	-2	89.2521	1	34	30.6120	21	70	11.9177	41	106	5.1373
-38	-36	284.4189	-18	0	84.3147	2	36	29.1197	22	72	11.4018	42	108	4.9373
-37	-35	266.5373	-17	1	79.6808	3	37	27.7088	23	73	10.9112	43	109	4.7460
-36	-33	249.8958	-16	3	75.3299	4	39	26.3744	24	75	10.4443	44	111	4.5631
-35	-31	234.4009	-15	5	71.2430	5	41	25.1119	25	77	10.0000	45	113	4.3881
-34	-29	219.9666	-14	7	67.4028	6	43	23.9172	26	79	9.5754	46	115	4.2208
-33	-27	206.5140	-13	9	63.7928	7	45	22.7861	27	81	9.1711	47	117	4.0607
-32	-26	193.9703	-12	10	60.3980	8	46	21.7151	28	82	8.7860	48	118	3.9074
-31	-24	182.2686	-11	12	57.2044	9	48	20.7004	29	84	8.4190	49	120	3.7607
-30	-22	171.3474	-10	14	54.1988	10	50	19.7390	30	86	8.0694	50	122	3.6202
-29	-20	161.1499	-9	16	51.3692	11	52	18.8277	31	88	7.7360	51	124	3.4857
-28	-18	151.6239	-8	18	48.7042	12	54	17.9636	32	90	7.4182	52	126	3.3568
-27	-17	142.7211	-7	19	46.1933	13	55	17.1440	33	91	7.1150	53	127	3.2333
-26	-15	134.3971	-6	21	43.8268	14	57	16.3665	34	93	6.8259	54	129	3.1150
-25	-13	126.6109	-5	23	41.5956	15	59	15.6286	35	95	6.5499	55	131	3.0016
-24	-11	119.3244	-4	25	39.4921	16	61	14.9280	36	97	6.2866	56	133	2.8928
-23	-9	112.5028	-3	27	37.5056	17	63	14.2629	37	99	6.0351	57	135	2.7886
-22	-8	106.1135	-2	28	35.6316	18	64	13.6310	38	100	5.7950	58	136	2.6886
-21	-6	100.1268	-1	30	33.8622	19	66	13.0307	39	102	5.5657	59	138	2.5926

S3010W1000 remote wall mounted temperature sensor, dip switch location

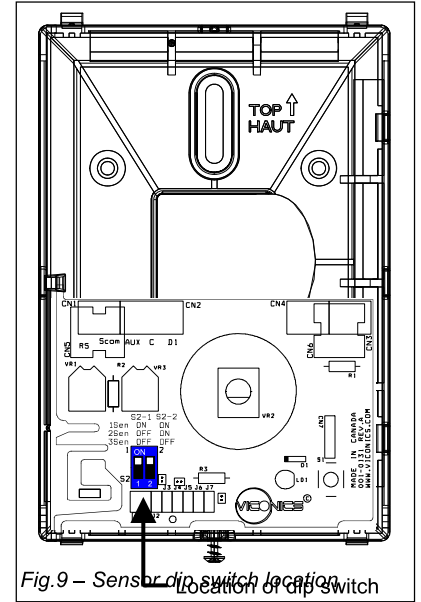

Fig.9 – Sensor dip switch location

S2000D1000, remote duct mounted temperature sensor c/w junction box.

This sensor can be used for:

- Remote return air temperature sensing with the sensor mounted on the return air duct.
- Outside air temperature sensing with the sensor installed in the fresh air plenum.
- Supply air temperature sensor

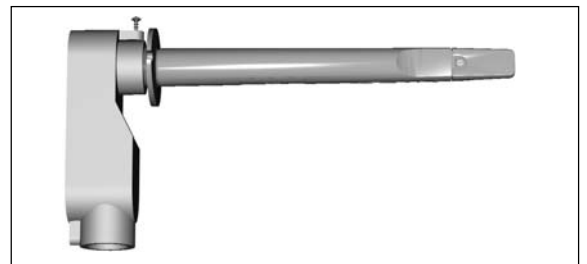

Fig.10 – Remote duct mounted temperature sensor

S2060A1000, remote averaging duct mounted temperature sensor c/w junction box.

This sensor can be used for:

- Remote averaging return air temperature sensing with the sensor mounted on the return air duct.
- Outside air temperature averaging sensing with the sensor installed in the fresh air plenum.
- Mixed air temperature averaging sensor for economizer models with the sensor in the mixing plenum.

S2020E1000, outdoor air temperature sensor

This sensor can be used for:

- Outside air temperature sensing with the sensor installed directly exposed to the elements.
- Sensor uses a water resistant NEMA 4 ABS enclosure for outdoor applications

WIRING S2000D1000, S2060A1000 and S2020E1000

Remote wiring 1 sensor

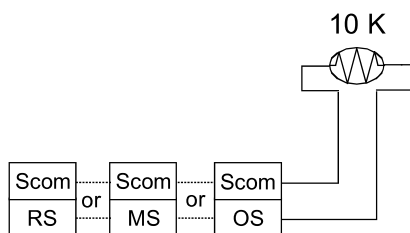

Remote wiring 4 sensors

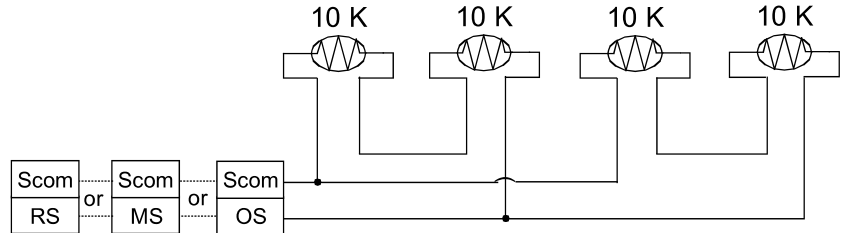

User menu flow chart:

NOTE: Prompts may not all be present depending on model selected

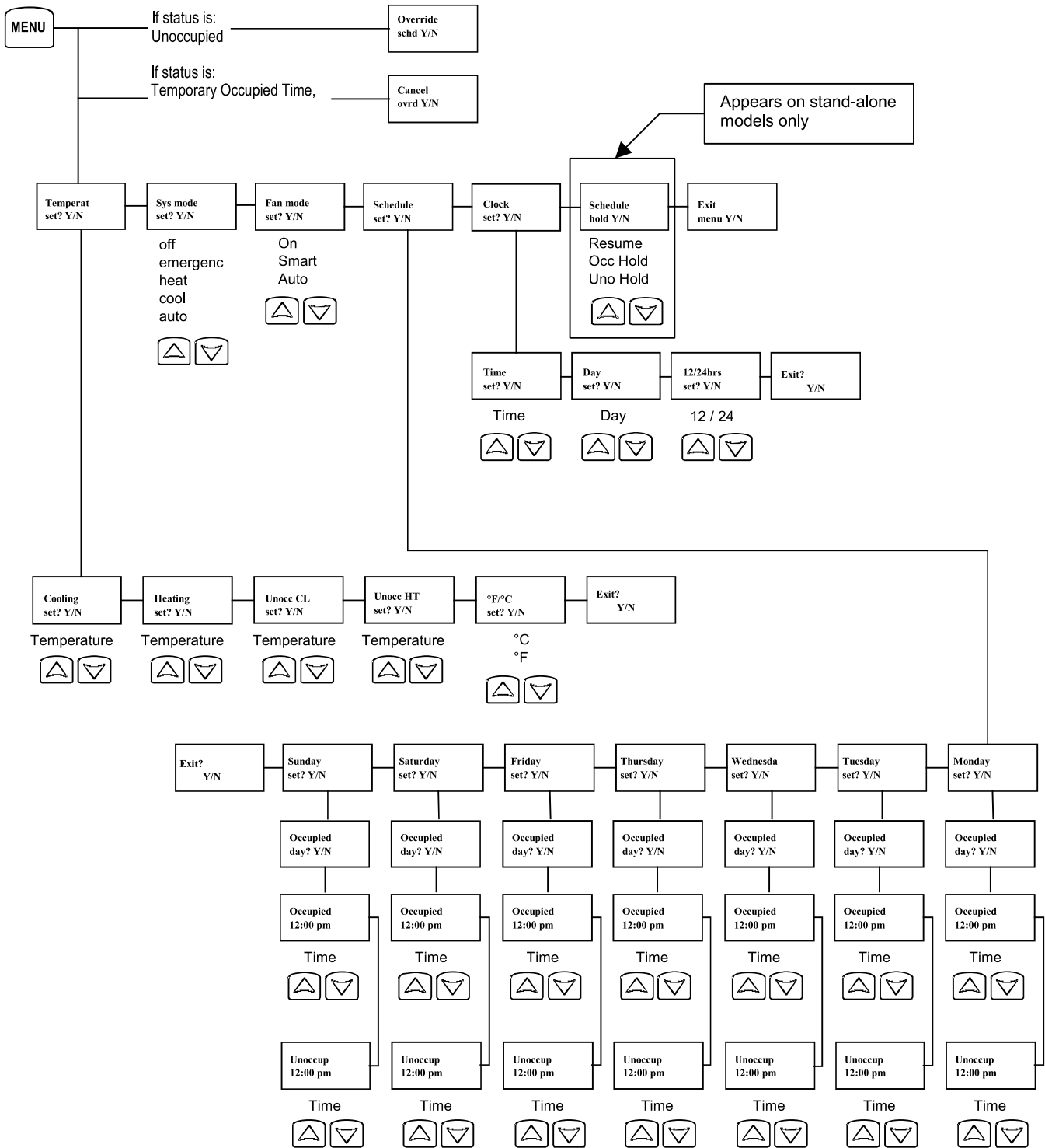

Programming and status display instructions

1. Status display

The thermostat features a two-line, eight-character display. There is a low level back-light level that is always active and can only be seen at night. When left unattended, the thermostat has an auto scrolling display that shows the actual status of the system. Each item is scrolled one by one with the back lighting off. Pressing any key will cause the back light to come on.

Sequence of auto-scroll status display:

Room temperature	Clock status	System mode	Schedule status	Outdoor temperature	Alarms
RoomTemp x.x °C or °F	Monday 12.00 AM	Sys mode auto	Occupied	Outdoor x.x °C or °F	Service
		Sys mode off	Occupied hold		Frost ON
		Sys mode heat	Unoccup		SetClock
		Sys mode cool	Unoccup hold		Filter
		Sys mode emergenc	Override		

Manual scroll of each menu item is achieved by pressing the Yes (scroll) key repetitively. The last item viewed will be shown on the display for 30 seconds before returning to automatic scrolling. Temperature is automatically updated when scrolling is held.

Outdoor air temperature display is only enabled when outdoor air temperature sensor is connected.

- A maximum range status display of 50 °C (122 °F) indicates a shorted sensor. Associated functions, such as mode lockouts and economizer function are automatically disabled.
- A minimum range status -40 °C (-40 °F) is not displayed and indicates a opened sensor or a sensor not connected. Associated functions, such as mode lockouts and economizer function are automatically disabled.

If alarms are detected, they will automatically be displayed at the end of the status display scroll. During an alarm message display, the back lit screen will light up at the same time as the message and shut off during the rest of the status display. Two alarms maximum can appear at any given time. The priority for the alarms is as follows:

Frost ON	Indicates that the heating is energized by the low limit frost protection room temperature setpoint 5,6 °C (42 °F)
SetClock	Indicates that the clock needs to be reset. There has been a power failure which has lasted longer than 6 hours
Service	Indicates that there is a service alarm as per one of the programmable digital input (DI1 or DI2)
Filter	Indicates that the filters are dirty as per one of the programmable digital input (DI1 or DI2)

Three status LEDs on the thermostat cover are used to indicate the status of the fan, a call for heat, or a call for cooling.

Multistage and single stage models

- When the fan is on, the FAN LED will illuminate.
- When heating is on, the HEAT LED will illuminate.
- When cooling is on, the COOL LED will illuminate.

Heat pump models

- When the fan is on, the FAN LED will illuminate.
- When auxiliary heat is on, the AUX HEAT LED will illuminate.
- When compressor is on, the HEAT-PUMP LED will illuminate.

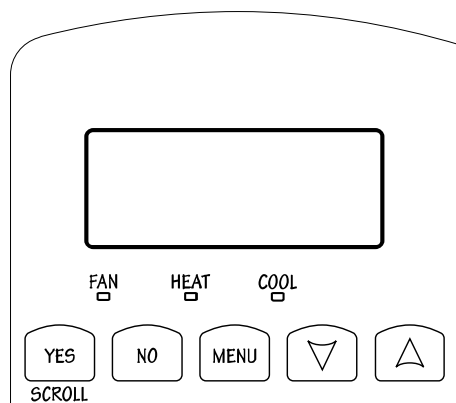

Fig. 11 - Multistage and single stage models

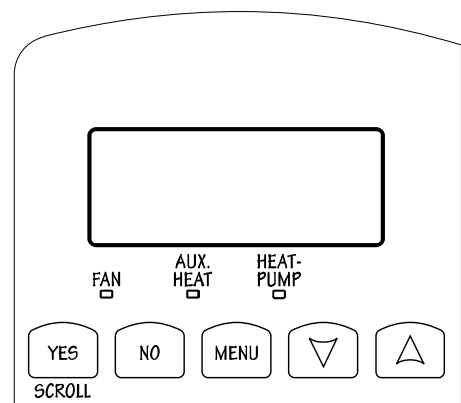

Fig. 12 – Heat pump models

2. User programming instructions menu

The VT7600 series of thermostat feature an intuitive, menu-driven, back-lit LCD display that walks users through the programming steps, making the programming process extremely simple. This menu is typically accessed by the user to set the parameters such as temperature and time events, system mode, fan mode, etc.

It is possible to bring up the user menu at any time by depressing the MENU key. The status display automatically resumes after exiting the user-programming menu.

If the user pauses at any given time during programming, **Auto Help** text is displayed to help and guide the user through the usage and programming of the thermostat.

Ex.: Press yes key to change cooling temperature setpoint
Use the up or down arrow to adjust cooling setpoint

Each of the sections in the menu are accessed and programmed using 5 keys on the thermostat cover.
The priority for the alarms is as follows:



The YES key is used to confirm a selection, to move onto the next menu item and to manually scroll through the displayed information.



The NO key is used when you do not desire a parameter change, and to advance to the next menu item. Can also be used to toggle between heating and cooling setpoints.



The MENU key is used to access the Main User Menu or exit the menu.



The down arrow key is used to decrease temperature setpoint and to adjust the desired values when programming and configuring the thermostat.



The up arrow key is used to increase temperature setpoint and to adjust the desired values when programming and configuring the thermostat.

When left unattended for 45 seconds, the display will resume automatic status display scrolling.

To turn on the back light, press any key on the front panel. The back lit display will turn off when the thermostat is left unattended for 45 seconds

Sequence of user menu:

Override Resume	Temperature setpoints	System mode setting	Fan mode setting	Schedules setting	Clock setting	Schedule hold
Override schd Y/N	Temperat set Y/N	Sys mode set Y/N	Fan mode set Y/N	Schedule set Y/N	Clock set Y/N	Schedule hold Y/N
Appears only in unoccupied mode						Appears only on stand-alone models
Cancel ovrd Y/N						
Appears only in override mode						

There is a default profile set in the thermostat from the factory.

This enables the thermostat to operate as a non-programmable unit in day mode operation at start up.

Programmed default temperature setpoints:	Programmed default modes:
Occupied cooling setpoint = 24 °C (75 °F)	System mode = Auto
Occupied heating setpoint = 22 °C (72 °F)	Fan mode = Smart (for models with a communication module or programmable stand-alone models)
Unoccupied cooling setpoint = 28 °C (82 °F)	Fan mode = Auto (for non-programmable stand-alone models)
Unoccupied heating setpoint = 18 °C (65 °F)	Programmed default schedules:
Fahrenheit scale	Monday through Sunday
Setpoint type = permanent	Occupied time is: 12 00 AM
	Unoccupied time is: 11:59 PM

There will be a 1 minute unoccupied period every night at 11:59 PM with this default configuration.

A) Override an unoccupied period

Override sched Y/N

This menu will appear only when the thermostat is in unoccupied mode. The unoccupied mode is enabled either by the internal timer scheduling or by a remote NSB contact via DI1 or DI2.

If DI1 or DI2 is configured to operate as a remote temporary override contact, this menu will be disabled.

Answering yes to this prompt will cause the thermostat to go into occupied mode for an amount of time equal to the parameter "TOccTime" (1 to 12 hours).

B) Resume regular scheduling

Cancel ovrd Y/N

This menu does not appear in regular operation. It will appear only when the thermostat is in Unoccupied override mode.

Answering "Yes" to this question will cause the thermostat to resume the regular programmed setpoints & scheduling.

C) Temperature setpoints

Permanent setpoint changes

Temperat set Y/N

This menu permits the adjustment of all permanent temperature setpoints (occupied and unoccupied) as well as the desired temperature units (°F or °C). Permanent setpoints are written to RAM and EEPROM

Cooling setpoint Occupied mode		Heating setpoint Occupied mode		Cooling setpoint Unoccupied mode		Heating setpoint Unoccupied mode		°F or °C display setting	
Cooling set? Y/N	No next → Yes down ↓	Heating set? Y/N	No next → Yes down ↓	Unocc CL set? Y/N	No next → Yes down ↓	Unocc HT set? Y/N	No next → Yes down ↓	°F or °C set? Y/N	No next → Yes down ↓
Use ▲▼ keys to set value, Yes key to confirm									
Cooling 70.0 °F	Use ▲▼ To set value	Heating 68.00 °F	Use ▲▼ To set value	Unocc CL 80.0 °F	Use ▲▼ To set value	Unocc HT 60.0 °F	Use ▲▼ To set value	Units °F	Use ▲▼ To set value

Temporary setpoint changes

Temporary setpoints can be modified through the Up arrow key (▲) and the Down arrow keys (▼).

User will be prompted with the present mode (Heating or Cooling) of the thermostat and its setpoint.

The Up (▲) arrow key will increment the setpoint by 0.5 degree (F or C).

The Down (▼) arrow key will decrement the setpoint by 0.5 degree (F or C).

Press the Yes key to accept the new setpoint.

Local changes to the heating or cooling setpoints made by the user directly using the up or down arrow are temporary.

They will remain effective for the duration specified by ToccTime.

Setpoints will revert back to their default value after internal timer ToccTime expires.

If a permanent change to the setpoints is required, use the Temperat set ? menu

D) System mode setting

Sys mode set Y/N

This menu is accessed to set system mode operation

Use ▲▼ to set value, Yes key to confirm

Sys mode auto	Automatic mode Automatic changeover mode between heating and cooling operation
Sys mode cooling	Cooling mode Cooling operation mode only
Sys mode heating	Heating mode Heating operation mode only
Sys mode emergency	Emergency heat mode (heat pump models only) Forced auxiliary heat operation mode only
Sys mode off	Off mode Normal cooling or heating operation disabled If enabled in installer parameters, only the automatic heating frost protection at 50 °F (10 °C) is enabled

E) Fan mode setting

Fan mode set Y/N

This section of the menu is permits the setting of the fan mode operation. Use ▲▼ to set value, Yes key to confirm

Fan mode On	On fan mode Fan is on continuously, even when system mode is OFF.
Fan mode Auto	Automatic fan mode Fan cycles on a call for heating or cooling for both occupied & unoccupied periods.
Fan mode Smart	Smart fan mode During occupied periods, fan is on continuously. In unoccupied mode, fan cycles on a call for heating or cooling. This selection is available on all models with a communication module, on all stand-alone programmable models or if DI1 or DI2 is set to RemNSB on stand-alone non-programmable models

F) Schedule set (2 events)

Scheduling can have 2 or 4 events per day. This is set in the configuration menu as per parameter (2/4event)

Schedule set Y/N

This section of the menu permits the user to set the whether 2 or 4 events is needed. Each day can be tailored to specific schedules if needed.

- 2 events can be programmed per day.
- Occupied & unoccupied periods can be set for each day.

Monday timer Schedule set		Tuesday timer Schedule set		Wednesday timer Schedule set		Other days are identical
Monday set? Y/N	No next → Yes down ↓	Tuesday set? Y/N	No next → Yes down ↓	Wednesda set? Y/N	No next → Yes down ↓	Selects the day to be programmed or modified
Yes key to access day scheduling, No key to jump to next day						
Occupied Day? Y/N	No next → Yes down ↓	Occupied Day? Y/N	No next → Yes down ↓	Occupied Day? Y/N	No next → Yes down ↓	Yes = Daily schedules will be accessed No = Unoccupied mode all day
Yes key to access day scheduling, No key to jump to next day						
		Copy Y/N Previous	Yes next → No down ↓	Copy Y/N Previous	Yes next → No down ↓	Yes = Will copy previous day schedule No = Daily schedules will be accessed
Yes key to copy previous day, No key to set new time value for each day						
Occupied 00:00 AM	Use ▲▼ To set value	Occupied 00:00 AM	Use ▲▼ To set value	Occupied 00:00 AM	Use ▲▼ To set value	Sets Event # 1 Occupied time Will activate occupied setpoints
Use ▲▼ to set value, Yes key to confirm						
Unoccup 00:00 AM	Use ▲▼ To set value	Unoccup 00:00 AM	Use ▲▼ To set value	Unoccup 00:00 AM	Use ▲▼ To set value	Sets Event # 2 Unoccupied time Will activate unoccupied setpoints
Use ▲▼ to set value, Yes key to confirm						

Typical examples of a 2 event office schedule

Ex. #1 Office building closed all weekend

Event	Period #1 - Event #1		Period #1 - Event #2	
	Cool	Heat	Cool	Heat
	Occupied		Unoccupied	
	72 °F	70 °F	80 °F	62 °F
Monday	7.00 AM		6.00 PM	
Tuesday	7.00 AM		6.00 PM	
Wednesday	7.00 AM		6.00 PM	
Thursday	7.00 AM		6.00 PM	
Friday	7.00 AM		6.00 PM	
Saturday	12.00 PM *		12.00 PM *	
Sunday	12.00 PM *		12.00 PM *	

Note: 12:00 PM = Noon
12:00 AM = Midnight

Daily Occupancy
Day time only
Day time only
Day time only
Day time only
Day time only
Day time only
Unoccupied
Unoccupied

* Programming consecutive events to the same time will cause the thermostat to choose the last event as the time at which it will set its schedule. In the above example, the thermostat will control to the unoccupied set point until 7:00 AM Monday.

Ex. #2 Commercial building which is occupied all weekend

Event	Period #1 - Event #1		Period #1 - Event #2	
	Cool	Heat	Cool	Heat
	Occupied		Unoccupied	
	72 °F	70 °F	80 °F	62 °F
Monday	8.00 AM		5.00 PM	
Tuesday	8.00 AM		5.00 PM	
Wednesday	8.00 AM		5.00 PM	
Thursday	8.00 AM		5.00 PM	
Friday	8.00 AM		5.00 PM	
Saturday	12.00 AM **		11.59 PM **	
Sunday	12.00 AM **		11.59 PM **	

Daily Occupancy
Day time only
Day time only
Day time only
Day time only
Day time only
Day time only
Occupied
Occupied

** To program a day as occupied for 24 hours, set that day Occupied time to 12:00 AM and Unoccupied time to 11:59 PM There will be a 1 minute unoccupied period every night at 11:59 PM with this schedule configuration.

G) Schedule set (4 events)

Schedule set Y/N

This section of the menu permits the user to set the whether 2 or 4 events is needed. Each day can be tailored to specific schedules if needed.

- 4 events can be programmed per day.
- Occupied & Unoccupied periods can be set for each day.
- Programming the 3 rd. & 4 th. events to the same time will cancel the last period.

Monday timer Schedule set		Tuesday timer Schedule set		Wednesday timer Schedule set		Other days are identical
Monday set? Y/N	No next → Yes down ↓	Tuesday set? Y/N	No next → Yes down ↓	Wednesda set? Y/N	No next → Yes down ↓	Selects the day to be programmed or modified
Yes key to access day scheduling, No key to jump to next day						
Occupied Day? Y/N	No next → Yes down ↓	Occupied Day? Y/N	No next → Yes down ↓	Occupied Day? Y/N	No next → Yes down ↓	Yes = Daily schedules will be accessed No = Unoccupied mode all day
Yes key to access day scheduling, No key to jump to next day						
	Copy Y/N Previous		Yes next → No down ↓	Copy Y/N Previous	Yes next → No down ↓	Yes = Will copy previous day schedule No = Daily schedules will be accessed
Yes key to copy previous day, No key to set new time value for each day						
Occupied 00:00 AM	Use ▲▼ To set value	Occupied 00:00 AM	Use ▲▼ To set value	Occupied 00:00 AM	Use ▲▼ To set value	Sets Event # 1 Occupied time Will activate occupied setpoints
Use ▲▼ to set value, Yes key to confirm						
Unoccup 00:00 AM	Use ▲▼ To set value	Unoccup 00:00 AM	Use ▲▼ To set value	Unoccup 00:00 AM	Use ▲▼ To set value	Sets Event # 2 Unoccupied time Will activate unoccupied setpoints
Use ▲▼ to set value, Yes key to confirm						
Occupie2 00:00 AM	Use ▲▼ To set value	Occupie2 00:00 AM	Use ▲▼ To set value	Occupie2 00:00 AM	Use ▲▼ To set value	Sets Event # 3 Occupied time Will activate occupied setpoints
Use ▲▼ to set value, Yes key to confirm						
Unoccup2 00:00 AM	Use ▲▼ To set value	Unoccup2 00:00 AM	Use ▲▼ To set value	Unoccup2 00:00 AM	Use ▲▼ To set value	Sets Event # 4 Unoccupied time Will activate unoccupied setpoints
Use ▲▼ to set value, Yes key to confirm						

Ex. #1 Four event retail establishment schedule

Event	Period 1 - Event 1		Period 1 - Event 2		Period 2 - Event 3		Period 2 - Event 4		Daily Occupancy
Setpoint	Occupied		Unoccupied		Occupied		Unoccupied		
	Cool	Heat	Cool	Heat	Cool	Heat	Cool	Heat	
	72 °F	70 °F	80 °F	62 °F	72 °F	70 °F	80 °F	62 °F	
Monday	7.00 AM		5.00 PM		12.00 PM *		12.00 PM *		Day time only
Tuesday	7.00 AM		5.00 PM		12.00 PM *		12.00 PM *		Day time only
Wednesday	7.00 AM		5.00 PM		12.00 PM *		12.00 PM *		Day time only
Thursday	7.00 AM		5.00 PM		7.00 PM		10.30 PM		Day/evening time only
Friday	7.00 AM		5.00 PM		7.00 PM		10.30 PM		Day/evening time only
Saturday	12.00 PM *		12.00 PM *		12.00 PM *		12.00 PM *		Unoccupied
Sunday	12.00 PM *		12.00 PM *		12.00 PM *		12.00 PM *		Unoccupied

* Programming events to the same time will cancel the last period and leave the thermostat in unoccupied mode

Ex. #2 Residential

Event	Period 1 - Event 1		Period 1 - Event 2		Period 2 - Event 3		Period 2 - Event 4		Daily Occupancy
Setpoint	Occupied		Unoccupied		Occupied		Unoccupied		
	Cool	Heat	Cool	Heat	Cool	Heat	Cool	Heat	
	72 °F	70 °F	80 °F	62 °F	72 °F	70 °F	80 °F	62 °F	
Monday	6:00 AM		8:00 AM		4:00 PM		10:00 PM		Day/evening time only
Tuesday	6:00 AM		8:00 AM		4:00 PM		10:00 PM		Day/evening time only
Wednesday	6:00 AM		8:00 AM		4:00 PM		10:00 PM		Day/evening time only
Thursday	6:00 AM		8:00 AM		4:00 PM		10:00 PM		Day/evening time only
Friday	6:00 AM		8:00 AM		4:00 PM		11:30 PM		Day/evening time only
Saturday	8:00 AM *		8:00 AM *		8:00 AM *		11:59 PM *		Day time only
Sunday	12:00 AM *		12:00 AM *		12:00 AM *		11:59 PM *		Occupied all day

* Programming consecutive events to the same time will cause the thermostat to choose the last event as the time at which it will set its schedule. In the above example for Saturday, the thermostat will control to the occupied set point from 8:00 AM until 11:59 PM. Since it is desired to be in occupied mode throughout the night, then it is necessary to program the first event on Sunday at 12:00 AM. The thermostat will force a one minute unoccupied period for a one minute period (between 11:59 PM and 12:00 AM on Saturday)

H) Clock/Day Settings

Clock set Y/N

This section of the menu permits the user to set the time and day.

Time setting		Day setting		Time format setting	
Time set? Y/N	No next → Yes down ↓	Day set? Y/N	No next → Yes down ↓	12/24hrs set? Y/N	No = exit Yes down ↓
Time 0:00	Use ▲▼ To set value	Day Monday	Use ▲▼ To set value	12/24hrs 12 hrs	Use ▲▼ To set value

J) Schedule hold

Schedule hold Y/N

This menu

- This menu will only appear on stand-alone thermostat, e.i. without a BACnet / Echelon module.
- This section of the menu permits the user to set a permanent schedule hold, which bypasses the internal thermostat scheduling.
- The permanent schedule hold function is typically used for non-scheduled events that extend for various periods of time.
- Enabling a permanent occupied or permanent unoccupied schedule hold will cancel any active override.
- The use of temporary setpoints during permanent hold is permitted. The duration of the temporary setpoint is as set per the TOccTime parameter. Ex. 3 hours

Use ▲▼ to set value, Yes key to confirm

Schedule resume	<p>Resume regular scheduling cancels the permanent hold and re-enables the regular programming as set per internal scheduling or as per remote NSB via one of the DI's configured as remote NSB.</p> <p>This action can also be accomplished by using the Resume menu.</p> <p>Any temporary setpoint that are active will be left active for the duration of the period as set per the TOccTime parameter.</p>
Schedule occ hold	<p>Hold permanent occupied forces the thermostat into a permanent occupied mode using the occupied setpoints. All timed scheduling functions are by-passed.</p> <p>The PERMANENT OCCUPIED status will appear in the automatic status scroll. To resume to regular scheduling, user must scroll to the Schedule Hold menu and select the Schedule resume option..</p>
Schedule uno hold	<p>Hold permanent unoccupied forces the thermostat into a permanent unoccupied mode using the unoccupied setpoints. All timed scheduling functions are by-passed.</p> <p>The PERMANENT UNOCCUPIED status will appear in the automatic status scroll. To resume to regular scheduling, user must scroll to the Schedule Hold menu and select the Schedule resume option..</p>

Installer configuration parameter menu

Configuration can be done through the network or locally at the thermostat.

- To enter configuration, press and hold the middle button (**Menu**) for 8 seconds
- Press the same middle button repetitively to scroll between all the available parameters
- Use the up and down key to change the parameter to the desired value.
- To acknowledge and save the new value, press the middle button again.
- The next listed parameter is now displayed

Configuration parameters	Significance Default value	Adjustments						
DI 1	Digital input no.1 configuration Open contact input = function not energized Closed contact input = function energized Default value = None	None , No function will be associated with the input Rem NSB , remote NSB timer clock input. Will disable the internal scheduling of the thermostat. The scheduling will now be set as per the digital input. The time is still displayed as information, but the menu part related to scheduling is disabled and no longer accessible. Open contact = occupied setpoints Closed contacts = unoccupied setpoints RemOVR Temporary override remote contact. Disables all override menu function of the thermostat. The override function is now controlled by a manual remote momentarily closed contact. When configured in this mode, the input operates in a toggle mode. With this function enabled it is now possible to toggle between unoccupied & occupied setpoints for the amount of time set by parameter (TOccTime) temporary occupancy time. When Override is enabled, an Override status message will be displayed Filter , a back-lit flashing Filter alarm will be displayed on the thermostat LCD screen when the input is energized Service , a back-lit flashing Service alarm will be displayed on the thermostat LCD screen when the input is energized						
DI 2	Digital input no. 2 configuration Default value = None	Same as above. It is possible to configure both inputs to have the same function.						
lockout	Keypad lockout levels Default value = 0 No lock	0 = No lock 1 = Low level 2 = High level						
Level	Resume/Override scheduling	Permanent Occupied and Unoccupied Setpoints	Temporary setpoints using arrows	System mode setting	Fan mode setting	Schedules setting	Clock setting	Permanent hold
	Resume sched Y/N	RoomTemp set Y/N	Up key (▲) Down key (▼)	Sys mode set Y/N	Fan mode set Y/N	Schedule set Y/N	Clock set Y/N	Schedule hold Y/N
0	Yes access	Yes access	Yes access	Yes access	Yes access	Yes access	Yes access	Yes access
1	Yes access	No access	Yes access	No access	No access	No access	Yes access	No access
2	No access	No access	No access	No access	No access	No access	Yes access	No access
pwr del	Power-up delay Default value = 10 seconds	On initial power up of the thermostat (each time 24 Vac power supply is removed & re-applied) there is a delay before any operation is authorized (fan, cooling or heating). This can be used to sequence start up multiple units / thermostat in one location. 10 to 120 seconds						

Frost pr	Frost protection enabled Default value = Off On heat pump models the system mode will be forced to EMERGENCY mode if frost protection is activated	Off: no room frost protection On: room frost protection enabled in all system mode at: 42 °F (5.6 °C) Frost protection is enabled even in system Off mode Off or On
heat max	Maximum heating setpoint limit Default value = 90 °F (32 °C)	Maximum occupied & unoccupied heating setpoint adjustment. Heating setpoint range is: 40 to 90 °F (4.5 to 32.0 °C)
cool min	Minimum cooling setpoint limit Default value = 54 °F (12 °C)	Minimum occupied & unoccupied cooling setpoint adjustment. Cooling setpoint range is: 54 to 100 °F (12.0 to 37.5 °C)
Anticycle	Minimum on/off operation time for stages Default value = 2 minutes Anti-short cycling can be set to 0 minutes for equipment that posses their own anti cycling timer. Do not use that value unless the equipment is equipped with such internal timer. Failure to do so can damage the equipment.	Minimum On/Off operation time of cooling & heating stages. IMPORTANT, anti-short cycling can be set to 0 minutes for equipment that posses their own anti cycling timer. Do <u>not</u> use this value unless the equipment is equipped with such internal timer. Failure to do so can damage the equipment. 0, 1, 2, 3, 4 & 5 minutes
Heat cph	Heating stages cycles per hour Default value = 4 C.P.H. For multi stage models, heat cph applies to W1 & W2 For heat pump models, heat cph applies to W1 only (Emergency heat)	Will set the maximum number of heating stage cycles per hour under normal control operation. It represents the maximum number of cycles that the equipment will turn ON and OFF in one hour. Note that a higher C.P.H will represent a higher accuracy of control at the expense of wearing mechanical components faster. 3, 4, 5, 6,7 & 8 C.P.H.
cool cph	Cooling stages cycles per hour Default value = 4 C.P.H. For multi stage models, cool cph applies to Y1 & Y2 For heat pump models, cool cph applies to Y1 & Y2 in cooling and heating independently of the reversing valve position	Will set the maximum number of cooling stage cycles per hour under normal control operation. It represents the maximum number of cycles that the equipment will turned on and off in one hour. Note that a higher C.P.H will represent a higher accuracy of control at the expense of wearing mechanical components faster. 3 or 4 C.P.H.
Deadband	Minimum deadband Default value = 2.0 °F (1.1 °C)	Minimum deadband value between the heating and cooling setpoints. If modified, it will be applied only when any of the setpoints are modified. 2, 3 or 4 °F (1.0 to 2.0 °C)
fan cont	Fan control Default value = On For multi stage models, fan control applies to W1 & W2 For heat pump models, fan control applies to W1 only (Emergency heat)	Fan control in heating mode. When selecting On ; the thermostat in all cases will always control the fan (terminal G). Valid for On or Auto fan mode When selecting Off ; the fan (terminal G), when heating stages (terminals W1 & W2) are solicited, will not be energized. The fan in this case will be controlled by the equipment fan limit control. Valid only for Auto fan mode. On fan mode will leave the fan always on. On or Off

fan del	Fan delay Default value = Off	Fan delay extends fan operation by 60 seconds after the call for heating or cooling ends. Valid only for Auto fan mode. "On" fan mode will leave the fan always on. Off or On
Com Addr	Thermostat networking address Default value = 4 Range is: 0 to 254 <ul style="list-style-type: none"> • For BACnet MS-TP models valid range to use is from 1 to 127 • For wireless models valid range is 0 to 254 with a maximum of 30 thermostat per VGG 	Conditional parameter to BACnet MS-TP models (VT76xxX1000B) Conditional parameter to Wireless models (VT76xxX1000W) This parameter will only appear when a BACnet or wireless network adapter is present. If the thermostat is installed as a stand-alone unit or with an Echelon adapter, this parameter will not be used or displayed
ToccTime	Temporary occupancy time Default value = 3 hours	Temporary occupancy time with occupied mode setpoints when override function is enabled When the thermostat is in unoccupied mode, function is enabled with either the menu or DI1 or DI2 configured as remote override input. 0,1, 2, 3, 4, 5, 6, 7, 8, 9, 10, 11 & 12 hours
cal RS	Room air temperature sensor calibration Default value = 0.0 °F or °C	Offset that can be added/subtracted to actual displayed room temperature ± 5.0 °F (± 2.5 °C)
cal OS	Outside air temperature sensor calibration Default value = 0.0 °F or °C	Offset that can be added/subtracted to actual displayed outside air temperature ± 5.0 °F (± 2.5 °C)
H stage	Number of heating stages. Applicable to 2 stage models only Default value = 2 stages For heat pump models, H stage is limited to 1 stage only (W1 – Aux. Heat)	Will revert the operation of 2 stages thermostat to single stage operation only when the second heating step is not needed. 1 or 2 stages
C stage Or HP stage	Number of cooling stages 2 stages model only Default value = 2 stages For heat pump models, HP stage selects the number of compressor stages	Will revert the operation of 2 stage thermostat to single stage operation only when the second cooling step is not needed. 1 or 2 stages
H lock	Outside air temperature heating lockout Default value = 120 °F (49 °C)	Disables heating stage operation based on outdoor air temperature. Function will only be enabled if OS (outside air temperature sensor) is connected. From -15 °F up to 120 °F (-26 °C up to 49 °C)
C lock	Outside air temperature mechanical cooling lockout. Default value = -40 °F (-40 °C)	Disables cooling stage operation based on outdoor air temperature. On economizer model, free cooling will not be disabled by this function. Function will only be enabled if OS (outside air temperature sensor) is connected. From -40 °F up to 95 °F (-40 °C up to 35 °C)

2/4event	Number of events configuration Default value = 2 event	<p>2 events, will set up programming for the following Event 1 is for Occupied setpoints Event 2 is for Unoccupied setpoints 4 events, will set up programming for the following Event 1 is for Occupied setpoints Event 2 is for Unoccupied setpoints Event 3 is for Occupied setpoints Event 4 is for Unoccupied setpoints</p>		
aux cont	Auxiliary contact configuration Default value = N.O. normally open	<p>This contact can be used to energize peripheral devices such as: lighting equipment, exhaust fans, economizers, etc. This contact will operate in parallel with the internal occupied/unoccupied schedule of the thermostat or the remote NSB contact if DI1 or DI2 is used. When the system is in OFF mode, the contact will remain in its unoccupied status independently of the occupied / unoccupied schedule.</p>		
		Configured	Contact occupied status	Contact unoccupied status
		N.O.	Closed	Opened
		N.C.	opened	Closed
Prog rec	Progressive recovery enabled Default value = Off Progressive recovery is automatically disabled if DI 1 and / or DI 2 are configured remote NSB	<p>Off, = no progressive recovery The programmed occupied schedule time is the time at which the system will restart. On, = progressive recovery active. The programmed occupied schedule time is the time at which the desired occupied temperature will be attained. The thermostat will automatically optimize the equipment start time. In any case, the latest a system will restart is 10 minutes prior to the occupied period time.</p>		
Heat Pump models only				
high bp	High balance point Default value = 90 °F (32.0 °C) Function will only be enabled if OS (outside air temperature sensor) is connected.	<p>In <i>Heating or Auto mode</i>, it is the outside air temperature value at which the auxiliary heat will be cut off. Above that value, only the heat pump will be used to maintain the heating setpoint 34 to 90 °F (1.0 to 32.0 °C)</p>		
low bp	Low balance point Default value = -12 °F (-24 °C) Function will only be enabled if OS (outside air temperature sensor) is connected.	<p>In <i>Heating, Cooling or Auto mode</i>, it is the outside air temperature value at which the heat pump operation will be cut off. Below that value, only the auxiliary heat will be used to maintain the heating setpoint -40 to 30 °F (-40 to -1.0 °C)</p>		

Comf/eco	Comfort or economy mode Default value = Comfort	Sets the operation and interaction mode of the heat pump with the auxiliary heat. Comfort mode. In <i>Heating mode</i> . If the heat pump is not able to satisfy the heating setpoint, the auxiliary heat will be energized to satisfy the same heating setpoint. Economy mode. In <i>Heating mode</i> . If the heat pump is not able to satisfy the heating setpoint, the auxiliary heat will be energized to satisfy only when the temperature has dropped 2.0 °F (1.1 °C) below the heating setpoint. Selecting economy mode will add a deadband between the heatpump & auxiliary heat in heating mode. The actual temperature maintained will be lower than the true heating setpoint to maximize the heat pump operation. When the outdoor air temperature drops below the <i>low balance point</i> , the deadband will be eliminated and the auxiliary heat will maintain the true heating setpoint alone. Economy mode. In <i>Emergency mode</i> . If <i>Emergency heat mode</i> is selected, the setpoint maintained, will be the heating setpoint.
re valve	Reversing valve operation O/B Default value = O	Heat pump reversing valve operation O will energize the valve in cooling operation. B will energize the valve in heating operation O or B
comp/aux	Compressor/auxiliary interlock Default value = Off	Sets the operation and interaction mode of the heat pump with the auxiliary heat. Interlock Off. In <i>Heating mode</i> . If the heat pump is not able to satisfy the heating setpoint, the auxiliary heat will be energized at the same time as the heat pump stage. Typically applies when the air handler heat pump coil is installed before the auxiliary heat. (all electric systems) Interlock On. In <i>Heating mode</i> . If the heat pump is not able to satisfy the heating setpoint, the auxiliary heat will be energized and the heat pump will be cut off. Typically applies when the air handler heat pump coil is installed after the auxiliary heat. (add on systems) There is a 2 minute delay to restart the heat pump, when the auxiliary heat is shut down Off or On

Notes for Heat Pump models:

When the outside air sensor is not connected or is shorted, the thermostat bypasses:

- The heating lockout
- The cooling lockout
- The low balance point
- The high balance point

Heat Pump model when set in Emergency mode bypasses heating lockout and permits auxiliary heating whenever a heating demand occurs.

Economizer Model only																										
Chngstpt	Changeover setpoint Default value = 55 °F (13.0 °C)	In <i>Cooling</i> mode. The outside air temperature value at which the cooling will be switched over from mechanical (compressor) to free cooling (economizer) 14 to 70 °F (-10.0 to 21.0 °C)																								
min pos	Minimum position Default value = 0% <table border="1" data-bbox="344 445 787 598"> <thead> <tr> <th>Outside air percentage</th> <th>0%</th> <th>5%</th> <th>10%</th> <th>15%</th> <th>20%</th> <th>25%</th> <th>30%</th> </tr> </thead> <tbody> <tr> <td>Setting for 0-10 Vdc Actuators</td> <td>0%</td> <td>5%</td> <td>10%</td> <td>15%</td> <td>20%</td> <td>25%</td> <td>30%</td> </tr> <tr> <td>Setting for 2-10 Vdc Actuators</td> <td>0 to 20%</td> <td>24%</td> <td>28%</td> <td>32%</td> <td>36%</td> <td>40%</td> <td>44%</td> </tr> </tbody> </table>	Outside air percentage	0%	5%	10%	15%	20%	25%	30%	Setting for 0-10 Vdc Actuators	0%	5%	10%	15%	20%	25%	30%	Setting for 2-10 Vdc Actuators	0 to 20%	24%	28%	32%	36%	40%	44%	Outside air damper minimum position. Will be active only when fan is on (G terminal) and the internal or remote scheduling is in occupied mode. When internal or remote scheduling is in unoccupied mode and/or fan is off, minimum position will be set to 0% 0 to 100 % = 0 to 10 Vdc output range
Outside air percentage	0%	5%	10%	15%	20%	25%	30%																			
Setting for 0-10 Vdc Actuators	0%	5%	10%	15%	20%	25%	30%																			
Setting for 2-10 Vdc Actuators	0 to 20%	24%	28%	32%	36%	40%	44%																			
C mech	Mechanical cooling allowed Default value = Off	In <i>Cooling</i> mode. Allows the operation of the mechanical cooling if the free cooling (economizer) cannot maintain the cooling setpoint. Off Typically applies when the MS (mixed air temperature sensor) is installed after the mechanical cooling refrigeration coils. In this case, mechanical cooling will never operate at the same time as free cooling. On Typically applies when the MS (mixed air temperature sensor) is installed before the mechanical cooling refrigeration coils in the mixing plenum. In this case, mechanical cooling is allowed when the free cooling (economizer operation) cannot maintain the cooling setpoint. Off or On																								
mix stpt	Mixed air setpoint Default value = 55 °F (13.0 °C)	Free cooling mixed air setpoint when economizer mode is enabled. 50 to 90 °F (10.0 to 32.0 °C)																								
MS dis	Display mixed air temperature Economizer model only, only if sensor is installed	Used as diagnostic / service help to troubleshoot and diagnose economizer operation.																								

Wireless Model only		
PAN ID	Personal Area Network Identification Default value = 0 Range is: 0 to 500	<p>Conditional parameter to Wireless models (VT76xxX1000W)</p> <p>This parameter will only appear when a wireless network adapter is present. If the thermostat is installed as a stand-alone unit or with a BACnet or Echelon adapter, this parameter will not be used or displayed</p> <p>This parameter (Personal Area Network Identification) is used to link specific thermostats to a single specific Viconics wireless gateway (VWG) For every thermostat reporting to a gateway (maximum of 30 thermostats per gateway), be sure you set the SAME PAN ID value both at the gateway and the thermostat(s).</p> <p>The default value of 0 is NOT a valid PAN ID. The valid range of available PAN ID is from 1 to 500</p>
Channel	Channel selection Default value = 10 Range is: 10 to 26	<p>Conditional parameter to Wireless models (VT76xxX1000W)</p> <p>This parameter will only appear when a wireless network adapter is present. If the thermostat is installed as a stand-alone unit or with a BACnet or Echelon adapter, this parameter will not be used or displayed</p> <p>This parameter (Channel) is used to link specific thermostats to specific Viconics wireless gateway(s) (VWG) For every thermostat reporting to a gateway (maximum of 30 thermostats per gateway), be sure you set the SAME channel value both at the gateway and the thermostat(s).</p> <p><i>Viconics recommends using only the 2 last channels (25-2575MHz and 26-2580MHz)</i></p> <p>The default value of 10 is NOT a valid channel. The valid range of available channel is from 11 to 26</p>
Get From	Thermostat Get From another device configuration utility Default value = 0 Range is: 0 to 254	<p>Conditional parameter to Wireless models (VT76xxX1000W)</p> <p>This parameter / function is not currently supported by the wireless thermostats.</p>

Troubleshooting guide

All models

Symptom	Possible Cause	Corrective Action
No display on the thermostat	Absent or incorrect supply voltage	1. Check power supply voltage between C & RC to be from 19-30 Vac 2. Check for tripped fuse or circuit breaker
	Overloaded power transformer	Verify that the transformer used is powerful enough (enough VA's) to supply all controlled devices including the thermostat
Keyboard menu does not access all functions	Keyboard locked	Change configuration parameter LOCKOUT to value "0" to access all levels of the menu
Temperature setpoints revert to original value after a certain time period	Temporary setpoint option selected	1. The thermostat needs to be in Permanent setpoint mode for the new setpoint to be kept and memory and used all the time 2. Go to the Set temperature menu. 3. The last prompt is setpoint type. Set it to Permanent setpoint
Thermostat will not call for heating	Wrong mode selected	Select heating mode
	Thermostat in Unoccupied mode	Select Occupied Hold in Schedule hold or Override to force the thermostat Occupied heating setpoint
	Anticycle delay active	Wait, the anticycling period will end and the equipment will start
	Heating setpoint is satisfied	Raise the Heating setpoint
	Heating lockout attained	1. Mode is locked out based on outside air temperature 2. Change configuration parameter H Lock to value 120 °F (49 °C) to by-pass lockout
	Wiring error	1. Start the Fan by forcing the Fan ON mode 2. Put a jumper across terminals RH & W1. The heating should come ON. If it does not, verify wiring and check if a jumper is required between RC & RH
Thermostat will not call for cooling	Wrong mode selected	Select cooling mode
	Thermostat in Unoccupied mode	Select Occupied Hold in Schedule hold or Override to force the thermostat Occupied cooling setpoint
	Anticycle delay active	Wait, the anticycling period will end and the equipment will start
	Cooling setpoint is satisfied	Lower the cooling setpoint
	Cooling lockout attained	1. Mode is locked out based on outside air temperature 2. Change configuration parameter C Lock to value - 40 °F (-40 °C) to by-pass lockout
	Wiring error	1. Start the Fan by forcing the Fan ON mode 2. Put a jumper across terminals RC & Y1. The cooling should come ON. If it does not, verify wiring
The thermostat will not turn on the fan	Wrong mode selected	1. Start the Fan by forcing the Fan ON mode 2. Put a jumper across terminals RC & G. The fan should come ON. If it does not, verify wiring
	Wiring error	
Digital display shows missing digits or erratic segments	Defective display	Replace thermostat

Troubleshooting guide

Heatpump models

Auxiliary heat does not operate	Wrong mode selected	Select emergency heat mode
	Thermostat in Unoccupied mode	Select Occupied Hold in Schedule hold or Override to force the thermostat Occupied heating setpoint
	Anticycle delay active	Wait, the anticycling period will end and the equipment will start
	Heating setpoint is satisfied	Raise the Heating setpoint
	High Balance point attained	1.Mode is locked out based on outside air temperature 2.Change configuration parameter High BP to value 90 °F (32 °C) to by-pass lockout
	Heating lockout attained	1.Mode is locked out based on outside air temperature 2.Change configuration parameter H Lock to value 120 °F (49 °C) to by-pass lockout
	Wiring error	1. Start the Fan by forcing the Fan ON mode 2. Put a jumper across terminals RH & W1. The heating should come ON. If it does not, verify wiring and check if a jumper is required between RC & RH
Heat pump does not operate in heating mode	Wrong mode selected	Select heating mode
	Thermostat in Unoccupied mode	Select Occupied Hold in Schedule hold or Override to force the thermostat Occupied heating setpoint
	Anticycle delay active	Wait, the anticycling period will end and the equipment will start
	Heating setpoint is satisfied	Raise the Heating setpoint
	Low Balance point attained	1.Mode is locked out based on outside air temperature 2.Change configuration parameter Low BP to value - 12 °F (-24 °C) to by-pass lockout
	Heating lockout attained	1.Mode is locked out based on outside air temperature 2.Change configuration parameter H Lock to value 120 °F (49 °C) to by-pass lockout
	Wiring error	1. Start the Fan by forcing the Fan ON mode 2. Put a jumper across terminals RH & W1. The heating should come ON. If it does not, verify wiring and check if a jumper is required between RC & RH
	Wrong reversing valve configuration	1.Wrong selection of parameter Re Valve 2.Select O will energize the valve in cooling operation. Valve is normally heat. 3.Select B will energize the valve in heating operation. Valve is normally cool.

Specifications

Thermostat power requirements: 19-30 Vac 50 or 60 Hz; 2 VA (RC & C) Class 2
 RC to RH jumper 2.0 Amps 48 VA maximum

Operating conditions: 0 °C to 50 °C (32 °F to 122 °F)
 0% to 95% R.H. non-condensing

Storage conditions: -30 °C to 50 °C (-22 °F to 122 °F)
 0% to 95% R.H. non-condensing

Sensor: Local 10 K NTC thermistor

Resolution: ± 0.1 °C (± 0.2 °F)

Control accuracy: ± 0.5 °C (± 0.9 °F) @ 21 °C (70 °F) typical calibrated

Occupied and unoccupied setpoint range
 cooling: 12.0 to 37.5 °C (54 to 100 °F)

Occupied and unoccupied setpoint range
 heating: 4.5 °C to 32 °C (40 °F to 90 °F)

Room and outdoor air temperature range -40 °C to 50 °C (-40 °F to 122 °F)

Proportional band for room temperature control: Both outputs: 1.1°C (2.0°F)

Digital inputs: Relay dry contact only across C terminal to DI1 or DI2

Contact output rating: Each relay output: (Y1, Y2, G, W1, W2 & AU)
 30 Vac, 1 Amp. maximum
 30 Vac, 3 Amp. in-rush

Economizer analog output rating: 0 to 10 Vdc into 2KΩ resistance min.

Economizer analog output accuracy: ± 3% typical

Wire gauge 18 gauge maximum, 22 gauge recommended

Dimensions: 4.94" x 3.38" x 1.13"

Approximate shipping weight: 0.75 lb (0.34 kg)

Agency Approvals all models: **UL:** UL 873 (US) and CSA C22.2 No. 24 (Canada), File E27734 with CCN XAPX (US) and XAPX7 (Canada)
Industry Canada: ICES-003 (Canada)
FCC: Compliant to CFR 47, Part 15, Subpart B, Class A (US)

Agency Approvals Stand-Alone, BACnet & LON models **CE:** EMC Directive 89/336/EEC (Europe Union)
C-Tick: AS/NZS CISPR 22 Compliant (Australia / New Zealand)
 Supplier Code Number N10696

Agency Approvals Wireless models **FCC:** Compliant to: Part 15, Subpart C

THIS DEVICE COMPLIES WITH PART 15 OF THE FCC RULES. OPERATION IS SUBJECT TO THE FOLLOWING TWO CONDITIONS: (1) THIS DEVICE MAY NOT CAUSE HARMFUL INTERFERENCE, AND (2) THIS DEVICE MUST ACCEPT ANY INTERFERENCE RECEIVED, INCLUDING INTERFERENCE THAT MAY CAUSE UNDESIRE OPERATION.

Drawing & dimensions

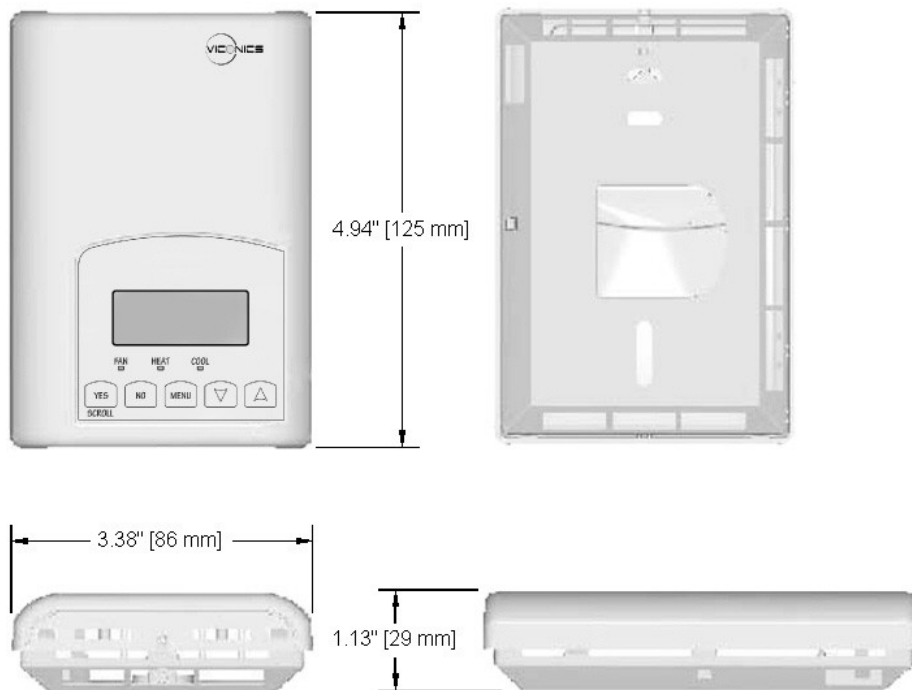

Important notice



All VT7600 series controls are for use as operating controls only and are not safety devices. These instruments have undergone rigorous tests and verifications prior to shipment to ensure proper and reliable operation in the field. Whenever a control failure could lead to personal injury and/or loss of property, it becomes the responsibility of the user / installer / electrical system designer to incorporate safety devices (such as relays, flow switch, thermal protections, etc...) and/or alarm system to protect the entire system against such catastrophic failures. Tampering of the devices or miss application of the device will void warranty.

Fig.13 – Thermostat dimensions

OA172 Series



AC Fan - 115V, 230V
172 x 51mm (6.7"x 2.0")

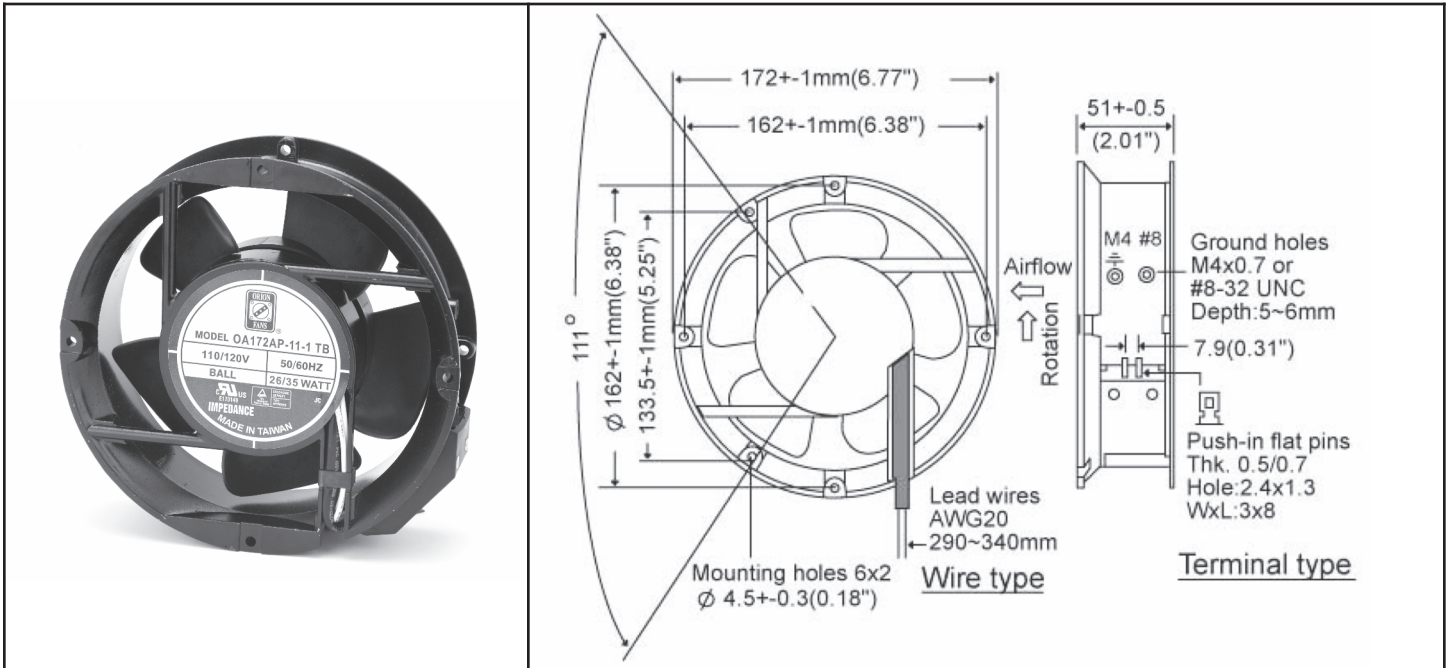

Frame	Diecast Aluminum	<p><u>Operating Temperature</u> Ball Bearing -40C ~ +70C Storage Temp -40C ~ +80C</p> <p><u>Life Expectancy</u> Ball Bearing 60,000 hours (L10 at 40C)</p> <p>Weight: ~ 2.7 lbs.</p>	
Impeller	PBT, UL94V-0 plastic		
Connection	2x Lead Wires or Terminals		
Motor	Capacitor drive, impedance protected		
Bearing System	Dual ball		
Insulation Resistance	>100M ohm between lead-wire and frame (500VDC)		
Dielectric Strength	1 min at 1500 VAC, 50/60Hz		

Model Number	Speed (RPM)	Airflow (CFM)	Noise (dB)	Volts AC	Voltage Range	Watts	Max. Static Pressure (\"H ₂ O)
OA172AP-11-1 *	3200	235	52	115	80~130	35	0.70
OA172AP-11-2 *	2400	170	42	115	80~130	20	0.49
OA172AP-11-3 *	1800	135	33	115	80~130	16	0.43
OA172AP-22-1 *	3200	235	52	230	160~260	35	0.70
OA172AP-22-2 *	2400	170	42	230	160~260	20	0.49
OA172AP-22-3 *	1800	135	33	230	160~260	16	0.43

* Indicate "TB" for Terminal type or "WB" for Wire Leads



CUSTOM AIR PRODUCTS & SERVICES, INC.

35 Southbelt Industrial Drive • Houston, Texas 77047

(713) 460-9009 • Fax (713) 460-9499

www.customairproducts.com

SECTION

07

ELECTRICAL DRAWINGS

POWER DISTRIBUTION BLOCK

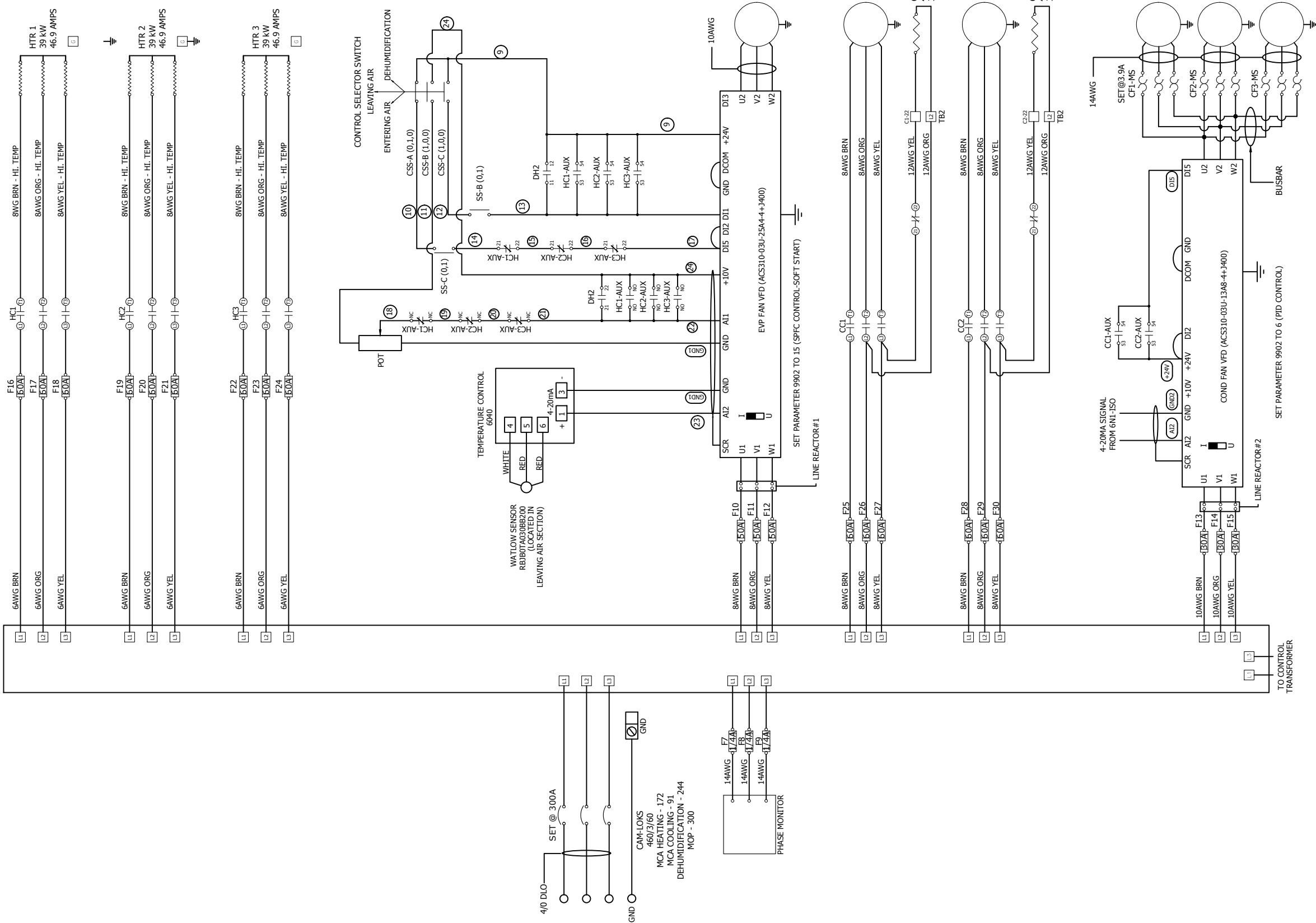

LOGO! SEQUENCE OF OPERATION

1- Compressor Sequence:
 The LOGO will begin the 15 second time delay upon a Y call from the thermostat. After the time delay expires, the compressor contactor will be energized as long as the high and low pressure switches are closed. If either switches is open after the delay expires, the compressor will not energize. If either switch opens while the compressor is energized, it will de-energize immediately and begin the anti-short cycle delay (1 minutes). The compressor will not be allowed to turn on again until the anti-short cycle delay expires and all switches are closed. The flow switch will have a 30-second bypass timer in which the control will ignore an open flow switch for the first 30-seconds. If the flow switch remains open after the 30-second bypass timer expires, the unit will de-energize the compressor and begin the anti-short cycle delay. If the control experiences three high pressure switch or low pressure switch faults in a 30-minute period, it will lock out the compressor. If the thermostat calls Y1 and Y2 at the same time, Compressor 1 contactor energizes first so does Compressor 2 contactor after 15 second delay.
 A manual reset of power will be required to reset the lockout condition.

2 Heater Sequence
 The LOGO will begin the 15 second time delay upon a W call from the thermostat. After the time delay expires, the heater contactor will be energized. The flow switch will have a 30-second bypass timer in which the control will ignore an open flow switch for the first 30-seconds. If the flow switch remains open after the 30-second bypass timer expires, the unit will de-energize the heater. If the thermostat calls W1 and W2 at the same time, Heat 1 contactor energizes first so does Heat 2 contactor after 15 second delay. A 30 second time delay between contactor 2 and contactor 3 is set

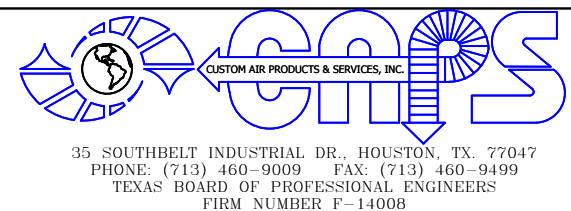

THIS DRAWING AND THE INFORMATION HEREIN CONTAINED ARE THE PROPERTY OF CUSTOM AIR PRODUCTS, WHICH HAS FURNISHED THEM IN CONFIDENCE UPON THE UNDERSTANDING AND CONDITION THAT ALL PERSONS, FIRMS OR CORPORATIONS RECEIVING SUCH DRAWINGS AND INFORMATION SHALL BY THE ACT OF RECEIVING THEM BE DEEMED TO HAVE AGREED: TO MAKE NO COPY, DUPLICATION, DISCLOSURE OR USE WHATSOEVER OF ALL OR ANY PART THEREOF EXCEPT AS EXPRESSLY AUTHORIZED IN WRITING BY CUSTOM AIR PRODUCTS: NOT TO GIVE, LEND OR OTHERWISE DISPOSE OF THIS DRAWING: AND TO RETURN THIS DRAWING PROMPTLY UPON REQUEST.

CERTIFIED AS-BUILT

CHECKER: _____ DATE: _____
 APPROVER: _____ DATE: _____

CAPS NO.: 17F-0868	DRAWING: AE1	DRAWN BY: TRUNG TRAN	DATE: 12/12/2017
CUST. PO#:	SHEET: 1 OF 6	CHECKED BY: DAVID NGUYEN	DATE: 12/13/2017
SIZE: B	REV: 0	APPROVED BY: LARRY NOVAK	DATE: 07/10/2018

REV#	DATE	DESIGNER	DESCRIPTION
0	12/12/2017	TRUNG TRAN	ISSUE FOR CONSTRUCTION
1	07/10/2018	J.O'MALLEY	AS BUILT

CUSTOMER: **HERC RENTALS**

40 TON PACKAGE UNIT WITH 117KW ELECTRIC HEATER VFD FOR EVAPORATOR CONDENSER FANS 460V/3PH/60HZ ELECTRICAL DESIGN HVAC WIRING DIAGRAM (HIGH VOLTAGE)

35 SOUTHBELT INDUSTRIAL DR., HOUSTON, TX. 77047
 PHONE: (713) 460-9009 FAX: (713) 460-9499
 TEXAS BOARD OF PROFESSIONAL ENGINEERS
 FIRM NUMBER F-14008

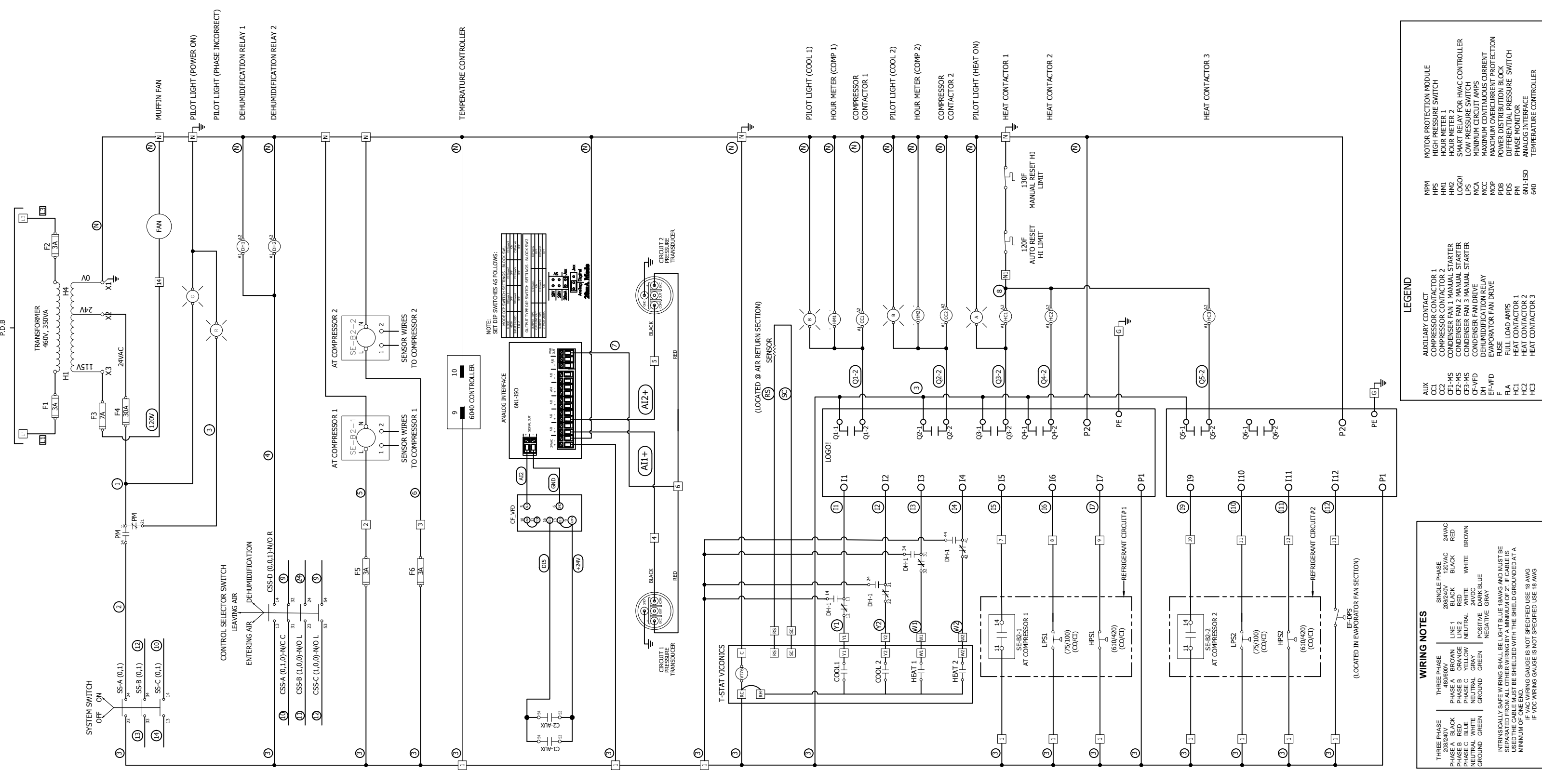

LEGEND

AUX	AUXILIARY CONTACT
CC1	COMPRESSOR CONTACTOR 1
CC2	COMPRESSOR CONTACTOR 2
CF1-MS	CONDENSER FAN 1 MANUAL STARTER
CF2-MS	CONDENSER FAN 2 MANUAL STARTER
CF3-MS	CONDENSER FAN 3 MANUAL STARTER
CF-VFD	CONDENSER FAN DRIVE
DH	DEHUMIDIFICATION RELAY
EF-VFD	EVAPORATOR FAN DRIVE
F	FUSE
FIA	FULL LOAD AMPS
HCL1	HEAT CONTACTOR 1
HCL2	HEAT CONTACTOR 2
HCL3	HEAT CONTACTOR 3
MPM	MOTOR PROTECTION MODULE
HPS	HIGH PRESSURE SWITCH
HIM1	HOURLY METER 1
HIM2	HOURLY METER 2
LOGO1	SMART RELAY FOR HVAC CONTROLLER
LPS	LOW PRESSURE SWITCH
MCA	MINIMUM CIRCUIT AMPS
MCC	MAXIMUM CONTINUOUS CURRENT
MOP	MAXIMUM OVERCURRENT PROTECTION
PDB	POWER DISTRIBUTION BLOCK
PDS	DIFFERENTIAL PRESSURE SWITCH
PM	PHASE MONITOR
6N1-150	ANALOG INTERFACE
640	TEMPERATURE CONTROLLER

WIRING NOTES

THREE PHASE	208/240V	BLACK	24WAC
PHASE A	208/240V	ORANGE	20WAC
PHASE B	208/240V	RED	RED
PHASE C	208/240V	YELLOW	WHITE
NEUTRAL	208/240V	GRAY	BROWN
GROUND	208/240V	GREEN	GRAY
POSITIVE	24VDC	GRAY	GRAY
NEGATIVE	24VDC	BLUE	BLUE

INTRINSICALLY SAFE WIRING SHALL BE LIGHT BLUE 18AWG AND MUST BE SEPARATED FROM ALL OTHER WIRING BY A MINIMUM OF 2". IF CABLE IS USED THE CABLE MUST BE SHIELDED WITH THE SHIELD GROUNDED AT A MINIMUM OF ONE END.
IF VAC WIRING GAUGE IS NOT SPECIFIED USE 18 AWG
IF VDC WIRING GAUGE IS NOT SPECIFIED USE 18 AWG

REV#	DATE	DESIGNER	DESCRIPTION
0	12/12/2017	TRUNG TRAN	ISSUE FOR CONSTRUCTION
1	07/10/2018	J.OMALLEY	AS BUILT

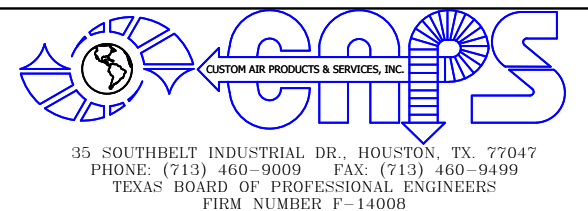

THIS DRAWING AND THE INFORMATION HEREIN CONTAINED ARE THE PROPERTY OF CUSTOM AIR PRODUCTS, WHICH HAS FURNISHED THEM IN CONFIDENCE UPON THE UNDERSTANDING AND CONDITION THAT ALL PERSONS, FIRMS OR CORPORATIONS RECEIVING SUCH DRAWINGS AND INFORMATION SHALL BY THE ACT OF RECEIVING THEM BE DEEMED TO HAVE AGREED: TO MAKE NO COPY, DUPLICATION, DISCLOSURE OR USE WHATSOEVER OF ALL OR ANY PART THEREOF EXCEPT AS EXPRESSLY AUTHORIZED IN WRITING BY CUSTOM AIR PRODUCTS: NOT TO GIVE, LEND OR OTHERWISE DISPOSE OF THIS DRAWING: AND TO RETURN THIS DRAWING PROMPTLY UPON REQUEST.

CERTIFIED AS-BUILT

CHECKER: _____ DATE: _____
APPROVER: _____ DATE: _____

CAPS NO.:	17F-0868	DRAWING:	AE2	DRAWN BY:	TRUNG TRAN	DATE:	12/12/2017
CUST. PO#:		SHEET:	2 OF 6	CHECKED BY:	DAVID NGUYEN	DATE:	12/13/2017
SIZE:	B	REV:	0	APPROVED BY:	LARRY NOVAK	DATE:	07/10/2018

CUSTOMER: **HERC RENTALS**

**40 TON PACKAGE UNIT WITH 117KW ELECTRIC HEATER
VFD FOR EVAPORATOR CONDENSER FANS
460V/3PH/60HZ
ELECTRICAL DESIGN
HVAC WIRING DIAGRAM (LOW VOLTAGE)**

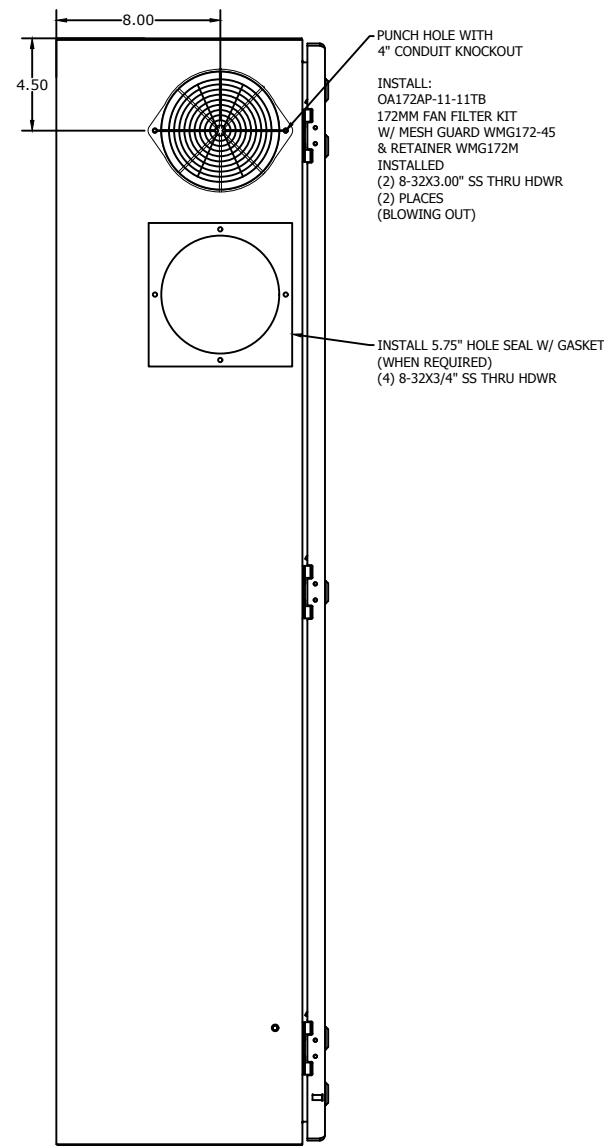

L.H. SIDE VIEW

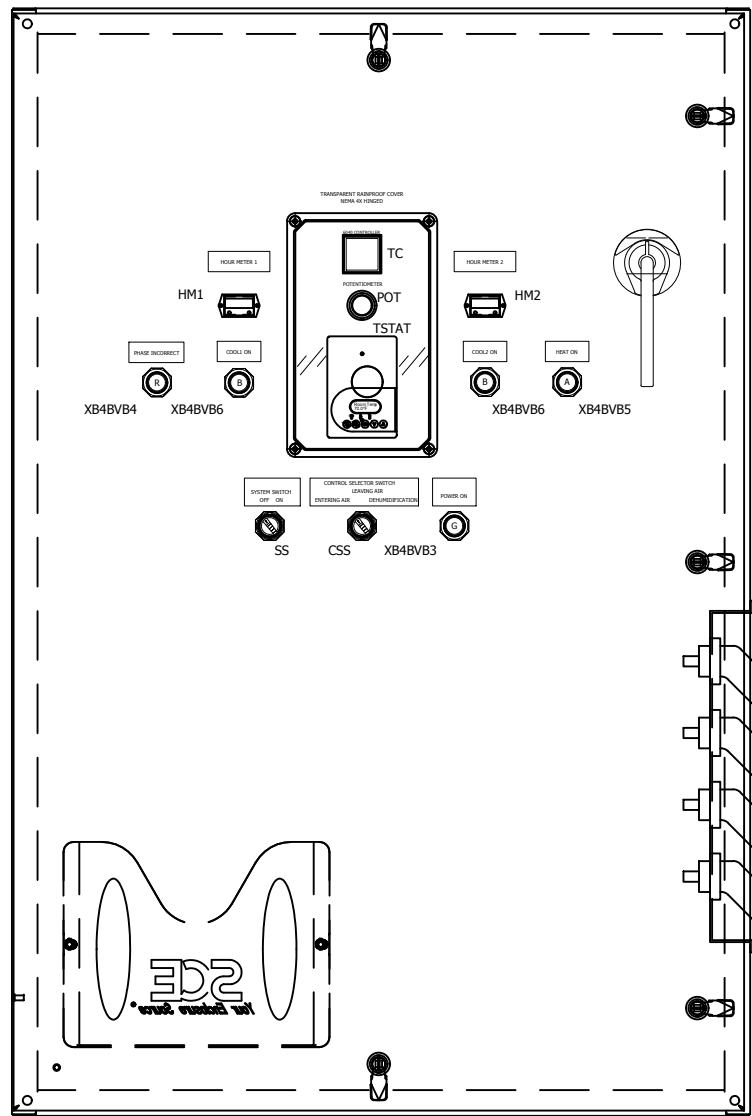

FRONT VIEW

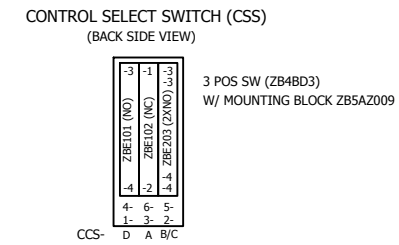
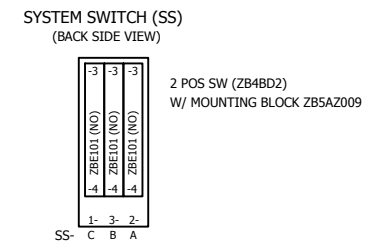

16R29 SERIES
USE 1/2" DIA CRIMP LUG
45 DEG

RECESSED CAM MOUNTING PLATE
(SEE ENGINEERING FOR
MOUNTING LOCATION & DETAILS)

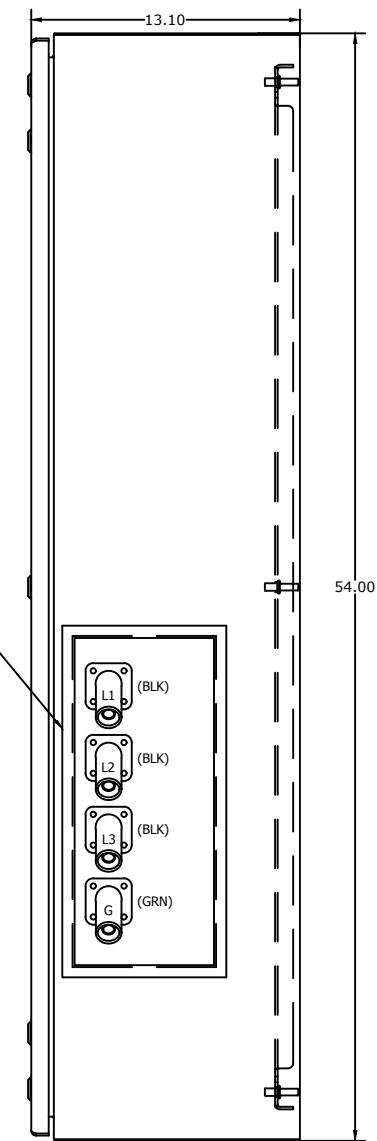

R.H. SIDE VIEW

LEGEND			
CC1	COMPRESSOR CONTACTOR 1	HC2	HEAT CONTACTOR 2
CC2	COMPRESSOR CONTACTOR 2	HC3	HEAT CONTACTOR 3
CF1-OL	CONDENSER FAN 1 OVERLOAD RELAY	HM1	HOUR METER 1
CF2-OL	CONDENSER FAN 2 OVERLOAD RELAY	HM2	HOUR METER 2
CF3-OL	CONDENSER FAN 3 OVERLOAD RELAY	LOGO!	SMART RELAY FOR HVAC CONTROLLER
CF-VFD	CONDENSER FAN DRIVE	PDB	POWER DISTRIBUTION BLOCK
DH	DEHUMIDIFICATION RELAY	PM	PHASE MONITOR
DOM	DELAY ON MAKE TIMER	6N1-ISO	ANALOG INTERFACE
EF-VFD	EVAPORATOR FAN DRIVE	640	TEMPERATURE CONTROLLER
F	FUSE	R1	EVAPORATOR RUN COMMAND RELAY
HCL	HEAT CONTACTOR 1		

NOTES:

1. MARK EACH DEVICE ON SIDE OF DEVICE, INSIDE OF ENCLOSURE.
2. SEE DRAWING NC-EMC012-P026 FOR ENCLOSURE CUTOUT DETAILS.
3. USE MOUNTING INSTRUCTIONS & HDWR PROVIDED WITH DEVICE UNLESS OTHERWISE SPECIFIED.

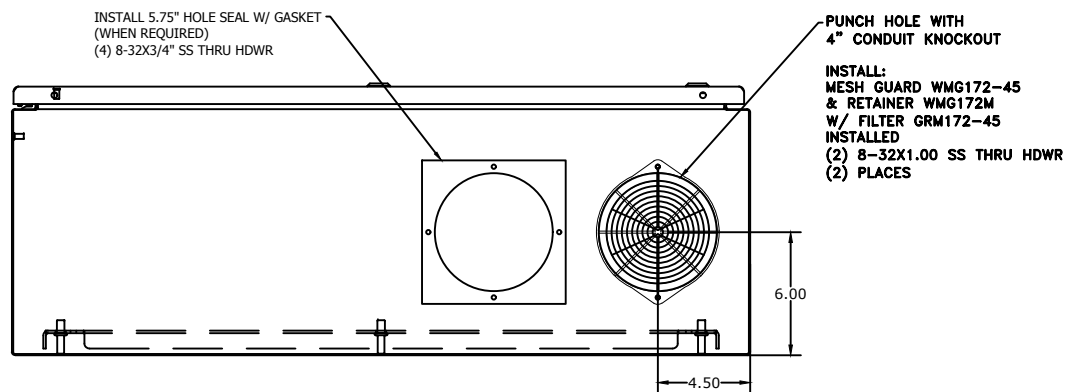

BOTTOM VIEW

REV#	DATE	DESIGNER	DESCRIPTION
0	12/12/2017	TRUNG TRAN	ISSUE FOR CONSTRUCTION
1	07/10/2018	J.O'MALLEY	AS BUILT

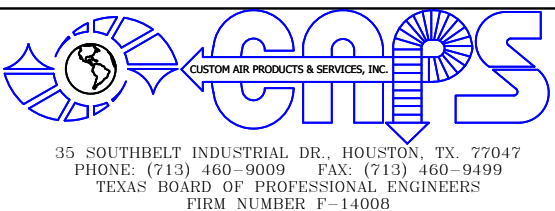

THIS DRAWING AND THE INFORMATION HEREIN CONTAINED ARE THE PROPERTY OF CUSTOM AIR PRODUCTS, WHICH HAS FURNISHED THEM IN CONFIDENCE UPON THE UNDERSTANDING AND CONDITION THAT ALL PERSONS, FIRMS OR CORPORATIONS RECEIVING SUCH DRAWINGS AND INFORMATION SHALL BY THE ACT OF RECEIVING THEM BE DEEMED TO HAVE AGREED: TO MAKE NO COPY, DUPLICATION, DISCLOSURE OR USE WHATSOEVER OF ALL OR ANY PART THEREOF EXCEPT AS EXPRESSLY AUTHORIZED IN WRITING BY CUSTOM AIR PRODUCTS: NOT TO GIVE, LEND OR OTHERWISE DISPOSE OF THIS DRAWING; AND TO RETURN THIS DRAWING PROMPTLY UPON REQUEST.

CERTIFIED AS-BUILT

CHECKER: _____ DATE: _____
APPROVER: _____ DATE: _____

CAPS NO.: 17F-0868
DRAWING: AE3
DRAWN BY: TRUNG TRAN
DATE: 12/12/2017

CUST. PO#: _____
SHEET: 3 OF 6
CHECKED BY: DAVID NGUYEN
DATE: 12/13/2017

SIZE: B
REV: 0
APPROVED BY: LARRY NOVAK
DATE: 07/10/2018

CUSTOMER: HERC RENTALS

40 TON PACKAGE UNIT WITH 117KW ELECTRIC HEATER
VFD FOR EVAPORATOR CONDENSER FANS
460V/3PH/60HZ
ELECTRICAL DESIGN
HVAC CONTROL PANEL LAYOUT (OUTSIDE)

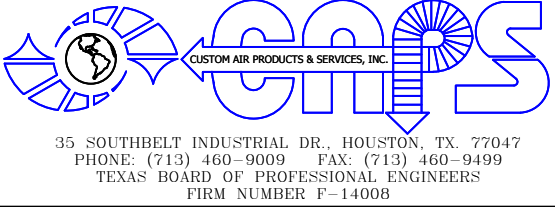

THIS DRAWING AND THE INFORMATION HEREIN CONTAINED ARE THE PROPERTY OF CUSTOM AIR PRODUCTS, WHICH HAS FURNISHED THEM IN CONFIDENCE UPON THE UNDERSTANDING AND CONDITION THAT ALL PERSONS, FIRMS OR CORPORATIONS RECEIVING SUCH DRAWINGS AND INFORMATION SHALL BY THE ACT OF RECEIVING THEM BE DEEMED TO HAVE AGREED: TO MAKE NO COPY, DUPLICATION, DISCLOSURE OR USE WHATSOEVER OF ALL OR ANY PART THEREOF EXCEPT AS EXPRESSLY AUTHORIZED IN WRITING BY CUSTOM AIR PRODUCTS: NOT TO GIVE, LEND OR OTHERWISE DISPOSE OF THIS DRAWING: AND TO RETURN THIS DRAWING PROMPTLY UPON REQUEST.

CERTIFIED AS-BUILT

CHECKER: _____ DATE: _____
 APPROVER: _____ DATE: _____

CAPS NO.:	17F-0868	DRAWING:	AE4	DRAWN BY:	TRUNG TRAN	DATE:	12/12/2017
CUST. PO#:		SHEET:	4 OF 6	CHECKED BY:	DAVID NGUYEN	DATE:	12/13/2017
SIZE:	B	REV:	0	APPROVED BY:	LARRY NOVAK	DATE:	07/10/2018

CUSTOMER:	HERC RENTALS
40 TON PACKAGE UNIT WITH 117KW ELECTRIC HEATER VFD FOR EVAPORATOR CONDENSER FANS 460V/3PH/60HZ ELECTRICAL DESIGN CONTROL PANEL COMPONENT LAYOUT	

REV#	DATE	DESIGNER	DESCRIPTION
0	12/12/2017	TRUNG TRAN	ISSUE FOR CONSTRUCTION
1	07/10/2018	J.OMALLEY	AS BUILT

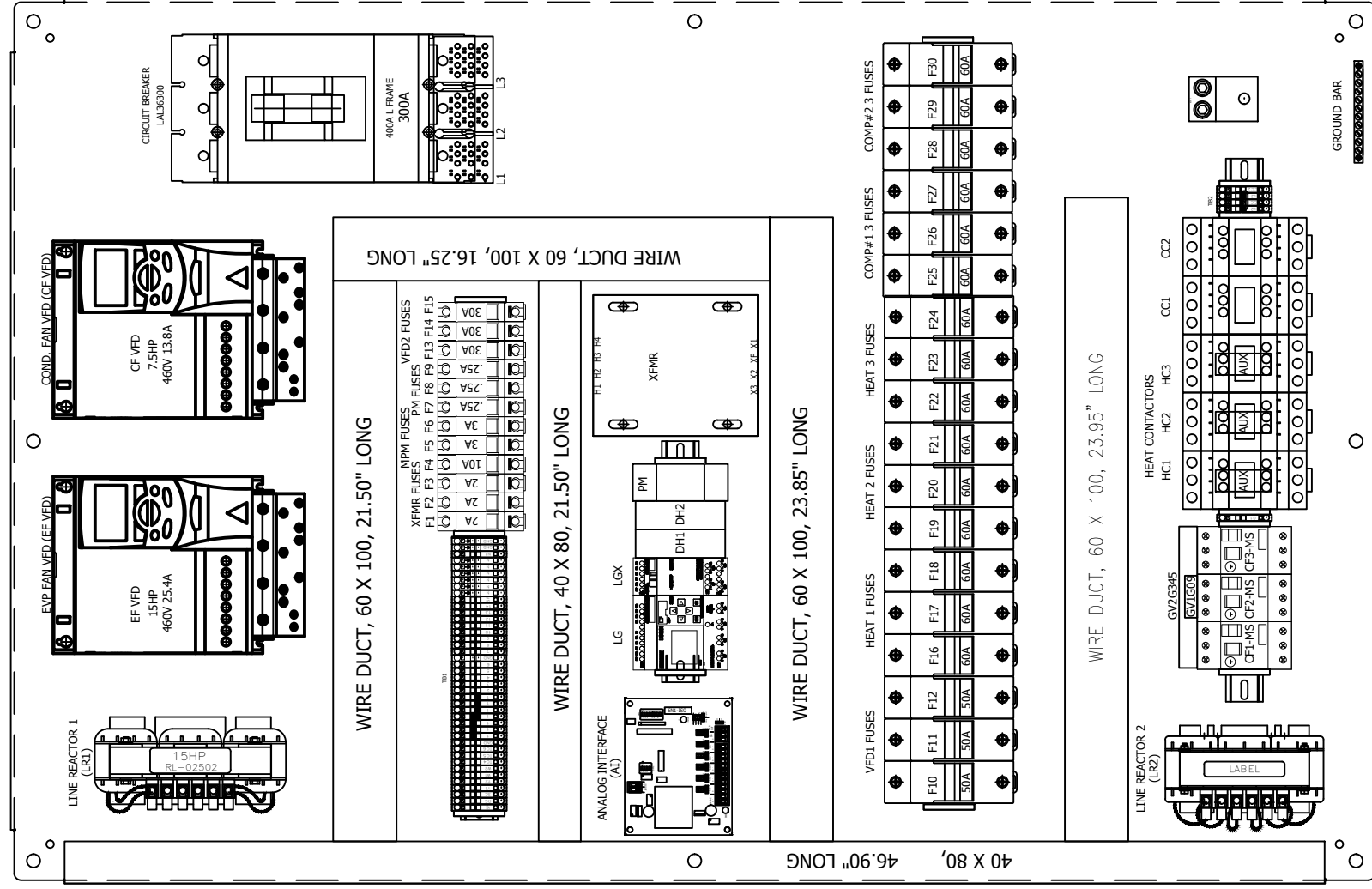
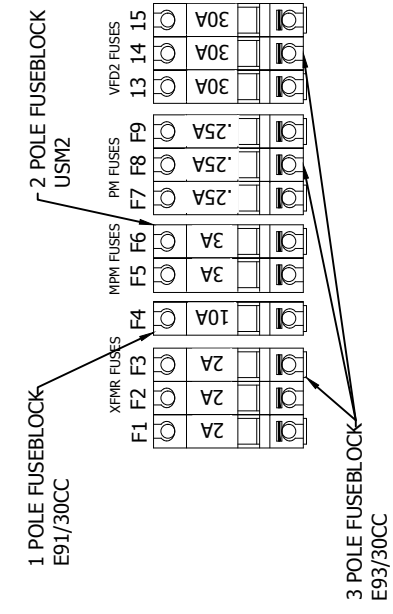

2004-404
PUSH-IN JUMPER
4 POSITION

2004-433
PUSH-IN JUMPER
POSITION 1&3

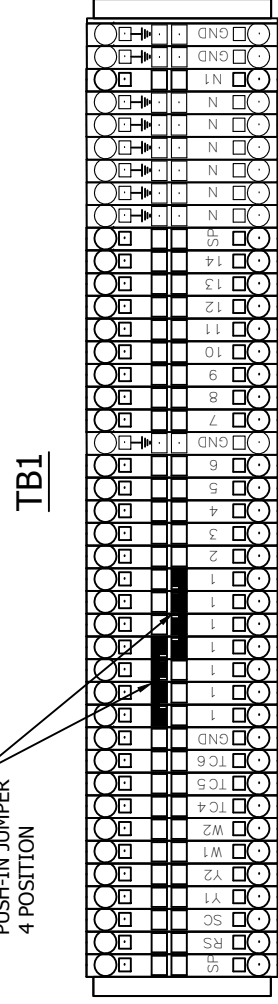

TERMINAL BLOCK DETAIL

- NOTES:**
1. TERMINAL MARKER FOR TERMINALS MARKED "SP" WILL BE BLANK TERMINAL MARKERS.
 2. EACH DEVICE TO HAVE (2) LABELS. ONE ON DEVICE, ONE ON PANEL BEHIND DEVICE.
 3. SEE NC-EMC012-P027 FOR BACK PANEL DIMENSION DETAILS.
 4. ALL DIN RAIL MOUNTED WITH 10-32X1/2 TT IN HOLES PROVIDED.
 5. ALL WIRE DUCT MOUNT WITH 8-32X1/2 TT IN HOLES PROVIDED.
 6. ALL OTHER DEVICES MOUNTED WITH 10-32X1/2 TT EXCEPT WHERE NOTED.
 7. REMOVE CONNECTION CAP FROM SIDE OF LOGO MODULE. ENGAGE INTERLOCK BETWEEN LOGO PRIMARY AND LOGO EXPANSION MODULE.

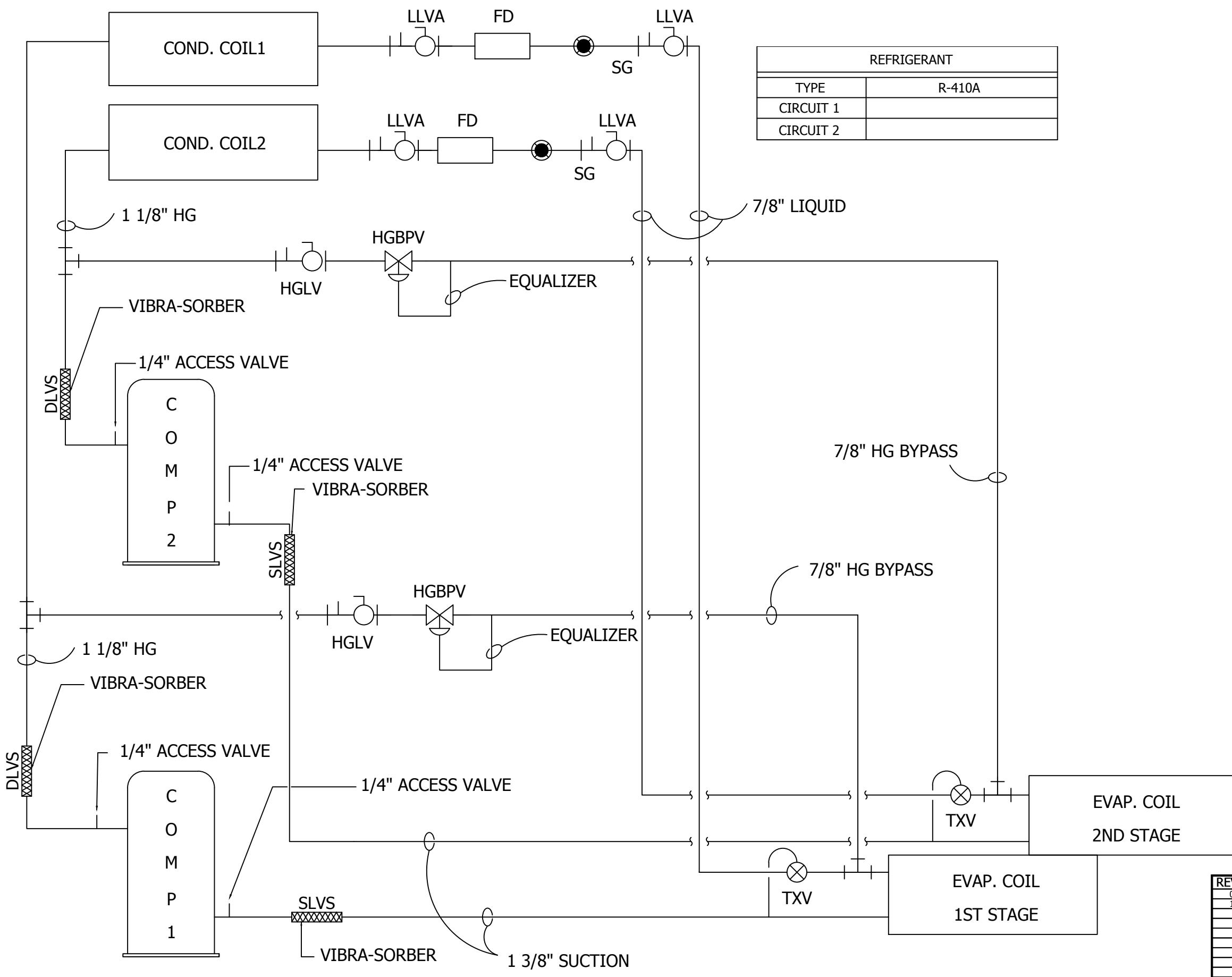

REFRIGERANT	
TYPE	R-410A
CIRCUIT 1	
CIRCUIT 2	

REV#	DATE	DESIGNER	DESCRIPTION
0	12/12/2017	TRUNG TRAN	ISSUE FOR CONSTRUCTION
1	07/10/2018	J.O'MALLEY	AS BUILT



THIS DRAWING AND THE INFORMATION HEREIN CONTAINED ARE THE PROPERTY OF CUSTOM AIR PRODUCTS, WHICH HAS FURNISHED THEM IN CONFIDENCE UPON THE UNDERSTANDING AND CONDITION THAT ALL PERSONS, FIRMS OR CORPORATIONS RECEIVING SUCH DRAWINGS AND INFORMATION SHALL BY THE ACT OF RECEIVING THEM BE DEEMED TO HAVE AGREED TO MAKE NO COPY, DUPLICATION, DISCLOSURE OR USE WHATSOEVER OF ALL OR ANY PART THEREOF EXCEPT AS EXPRESSLY AUTHORIZED IN WRITING BY CUSTOM AIR PRODUCTS. NOT TO GIVE, LEND OR OTHERWISE DISPOSE OF THIS DRAWING, AND TO RETURN THIS DRAWING PROMPTLY UPON REQUEST.

CERTIFIED AS-BUILT

CHECKER: _____ DATE: _____
 APPROVER: _____ DATE: _____

CAPS NO.:	17F-0868	DRAWING:	AE5	DRAWN BY:	TRUNG TRAN	DATE:	12/12/2017
CUST. PO#:		SHEET:	5 OF 6	CHECKED BY:	DAVID NGUYEN	DATE:	12/13/2017
SIZE:	B	REV:	0	APPROVED BY:	LARRY NOVAK	DATE:	07/10/2018

CUSTOMER: **HERC RENTALS**

**40 TON PACKAGE UNIT WITH 117KW ELECTRIC HEATER
 VFD FOR EVAPORATOR CONDENSER FANS
 460V/3PH/60HZ
 ELECTRICAL DESIGN
 P&ID**

SEQUENCE OF OPERATION

THE SYSTEM IS PLACED INTO INITIAL OPERATION AS FOLLOWS:

- TURN SYSTEM SWITCH TO "OFF"
- TURN CIRCUIT BREAKER "ON"
 - IF THE "PHASE INCORRECT" LIGHT IS ON, TURN OFF THE CIRCUIT BREAKER; REVERSE TWO (2) PHASE OF INCOMING POWER FOR PROPER PHASE SEQUENCING THEN CHECK THE INCOMING POWER SOURCE TO BE SURE THE UNIT HAS A GOOD POWER SOURCE 460V/3P/60HZ
 - IF THE "POWER ON" LIGHT IS ON AND THE "PHASE INCORRECT" LIGHT IS OFF, THE UNIT IS READY FOR OPERATION
- TURN SYSTEM SWITCH "ON"
- CONTROL SELECTOR SWITCH:
 - LEAVING: THE HVAC IS CONTROLLED BY THE LEAVING AIR TEMPERATURE
 - ENTERING: THE HVAC IS CONTROLLED BY THE RETURN AIR TEMPERATURE
 - DEHUMIDIFICATION: SYSTEM WILL BYPASS THERMOSTAT; BOTH HEAT AND COOL TURN ON AT THE SAME TIME TO REMOVE MOISTURE FROM THE ENTERING AIR
- THERMOSTAT SETTINGS:
 - PRESS MENU KEY TO ACCESS THE MAIN USER MENU OR EXIT THE MENU
 - PRESS THE DOWN ARROW KEY TO DECREASE "TEMPERATURE SETPOINTS" AND TO ADJUST THE DESIRED VALUES WHEN CONFIGURING THE TERMINAL EQUIPMENT CONTROLLER
 - PRESS THE UP ARROW KEY TO INCREASE "TEMPERATURE SETPOINTS" AND TO ADJUST THE DESIRED VALUES WHEN CONFIGURING THE TERMINAL EQUIPMENT CONTROLLER
 - PRESS THE "YES" KEY TO CONFIRM A SELECTION, TO MOVE ONTO THE NEXT MENU ITEM AND TO MANUALLY SCROLL THROUGH THE DISPLAYED INFORMATION
 - PRESS THE "NO" KEY WHEN YOU DO NOT DESIRE A PARAMETER CHANGE, AND TO ADVANCE TO THE NEXT MENU ITEM. CAN ALSO BE USED TO TOGGLE BETWEEN HEATING AND COOLING SETPOINTS.
 - DEPENDING ON THE DIFFERENCE BETWEEN SETPOINT TEMPERATURE AND ENTERING OR LEAVING TEMPERATURE. THERMOSTAT WILL CALL HEAT OR COOL. WHEN A COMPRESSOR ENERGIZES, IT'S PILOT LIGHT WILL TURN ON. WHEN HEAT IS ON, HEAT PILOT WILL TURN ON.
- IF A COMPRESSOR IS FAILED, IT WILL BE TURNED OFF AND LOCKED OUT
- ONLY USE SYSTEM SWITCH TO TURN OFF THE UNIT

REV#	DATE	DESIGNER	DESCRIPTION
0	12/12/2017	TRUNG TRAN	ISSUE FOR CONSTRUCTION
1	07/10/2018	J.O'MALLEY	AS BUILT

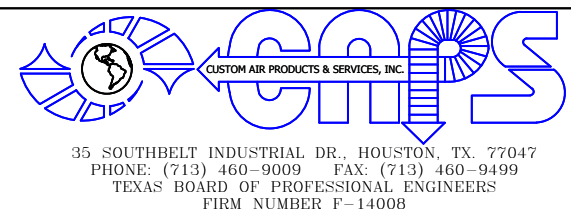

THIS DRAWING AND THE INFORMATION HEREIN CONTAINED ARE THE PROPERTY OF CUSTOM AIR PRODUCTS, WHICH HAS FURNISHED THEM IN CONFIDENCE UPON THE UNDERSTANDING AND CONDITION THAT ALL PERSONS, FIRMS OR CORPORATIONS RECEIVING SUCH DRAWINGS AND INFORMATION SHALL BY THE ACT OF RECEIVING THEM BE DEEMED TO HAVE AGREED: TO MAKE NO COPY, DUPLICATION, DISCLOSURE OR USE WHATSOEVER OF ALL OR ANY PART THEREOF EXCEPT AS EXPRESSLY AUTHORIZED IN WRITING BY CUSTOM AIR PRODUCTS; NOT TO GIVE, LEND OR OTHERWISE DISPOSE OF THIS DRAWING; AND TO RETURN THIS DRAWING PROMPTLY UPON REQUEST.

CERTIFIED AS-BUILT

CHECKER: _____ DATE: _____
 APPROVER: _____ DATE: _____

CAPS NO.: 17F-0868	DRAWING: AE6	DRAWN BY: TRUNG TRAN	DATE: 12/12/2017
CUST. PO#:	SHEET: 6 OF 6	CHECKED BY: DAVID NGUYEN	DATE: 12/13/2017
SIZE: B	REV: 0	APPROVED BY: LARRY NOVAK	DATE: 07/10/2018

CUSTOMER: **HERC RENTALS**

**40 TON PACKAGE UNIT WITH 117KW ELECTRIC HEATER
 VFD FOR EVAPORATOR CONDENSER FANS
 460V/3PH/60HZ
 ELECTRICAL DESIGN
 SEQUENCE OF OPERATION**



CUSTOM AIR PRODUCTS & SERVICES, INC.

35 Southbelt Industrial Drive • Houston, Texas 77047

(713) 460-9009 • Fax (713) 460-9499

www.customairproducts.com

SECTION

08

MECHANICAL DRAWINGS

* ACTUAL WEIGHT 7,260 LBS.

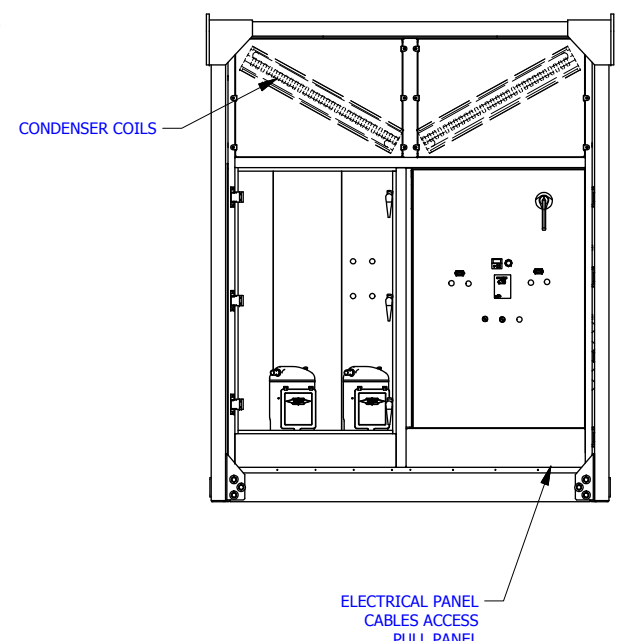
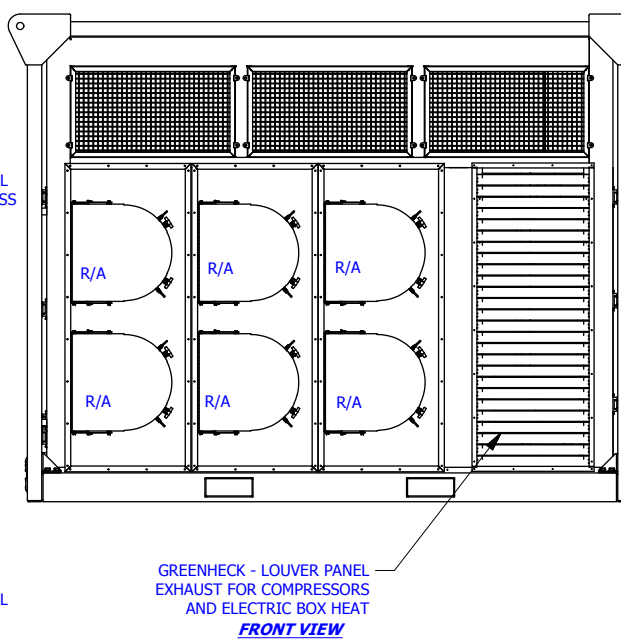
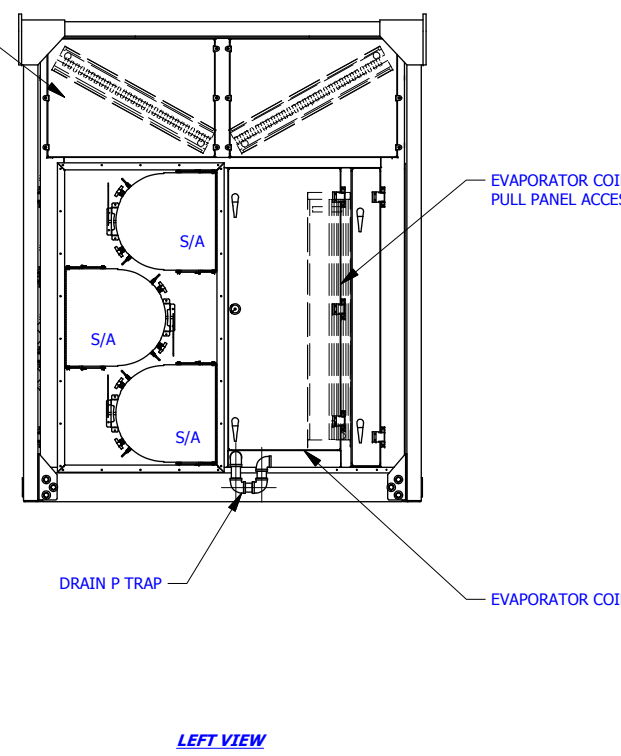
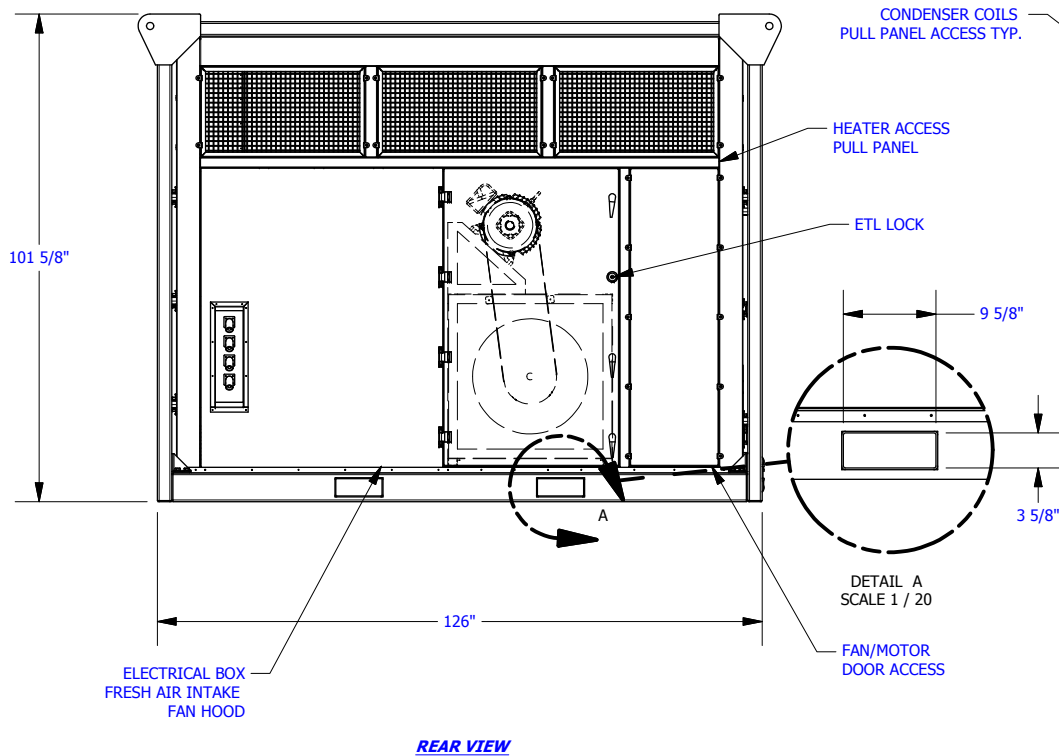
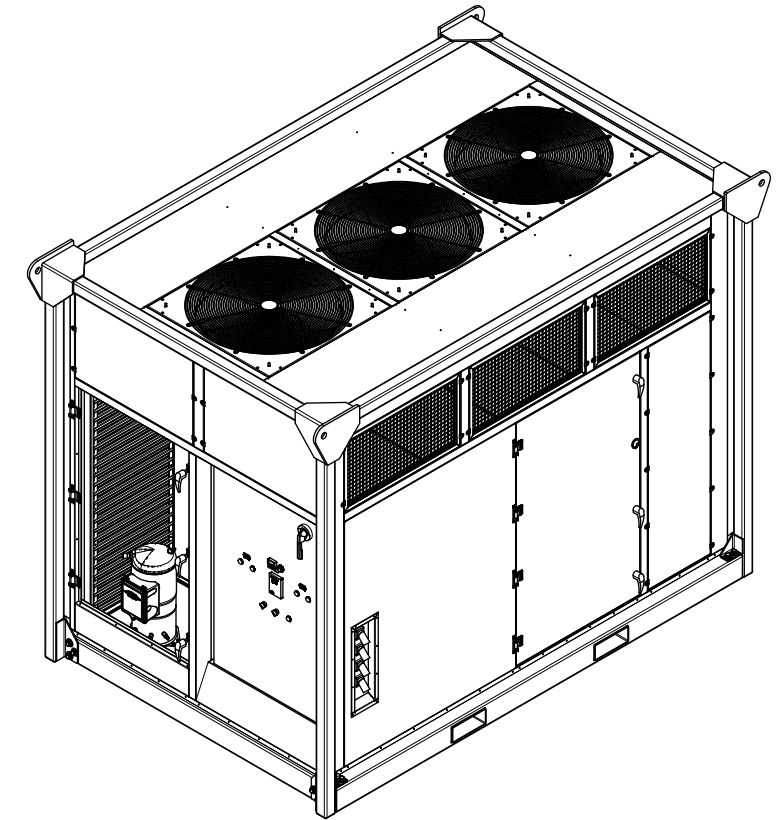
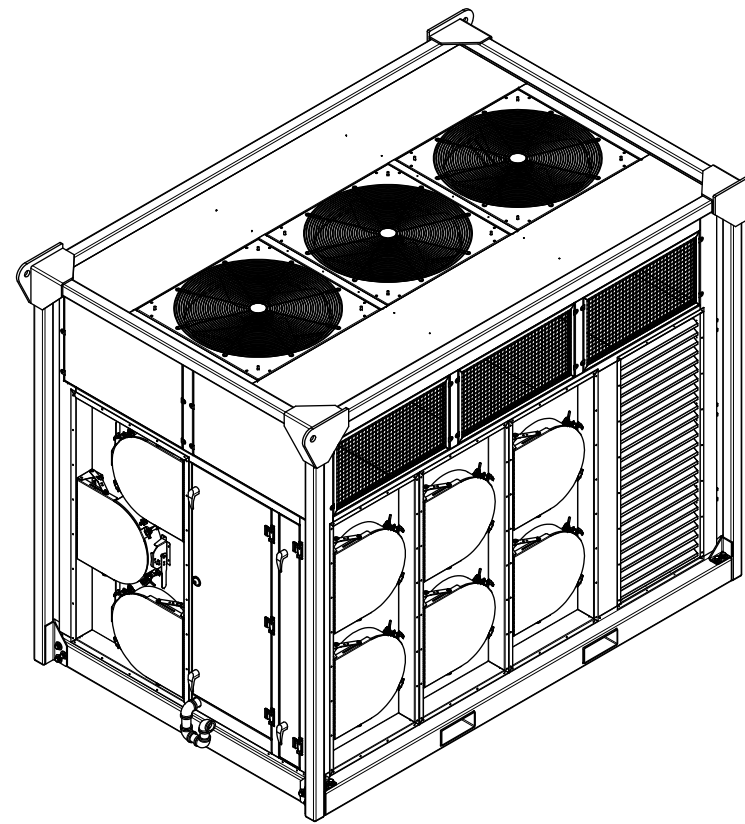
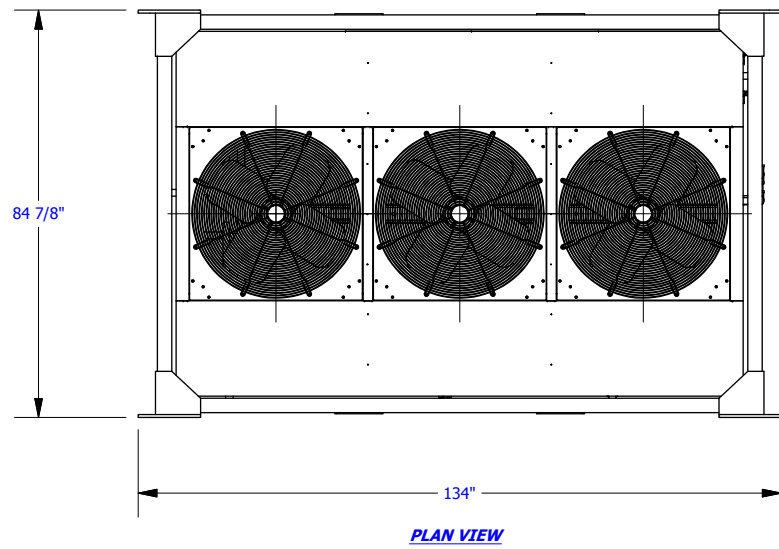

- NOTES:**
1. ALL DIMENSIONS SHOWN ARE IN INCHES.
 2. GASKET BETWEEN ALL EXTERIOR PANELS AND AROSIO AND ALL INTERNAL LINERS AND AROSIO.
 3. ALL DIMENSIONS ARE O.D. UNLESS OTHERWISE NOTED.
 4. SEAL WELD ON ALL JOINTS NEEDED.
 5. CAULK ALL SHEET METAL JOINTS.
 6. BREAK SHARP EDGES.

PART NUMBER: 40T-CS-000

REVISION HISTORY			
REV	DATE	DESIGNER	DESCRIPTION
1	11/13/2016	ALEX BANNISTER	INITIAL RELEASE
2	2/6/2017	ALEX BANNISTER	REVISED PER REDLINES
3	3/16/2017	JOSH REYNOLDS	REVISED PER ECN#00090
4	3/16/2017	ALEX BANNISTER	REVISED PER ECN#00093
5	3/24/2017	J.REYNOLDS	REVISED PER ECN# 00100/00101
6	3/28/2017	ALEX BANNISTER	DOOR ADJUSTED TO HAVE 1/8" ALL AROUND PER CAPS STANDARD SHM-0020 ECN#00102
7	5/15/2017	ALEX BANNISTER	ELECTRICAL PANEL HEIGHT WAS ADJUSTED PER REDLINES ON 17F-0026
8	12/12/2017	ALEX BANNISTER	UPDATED PER ECR#00269



THIS DRAWING AND THE INFORMATION HEREIN CONTAINED ARE THE PROPERTY OF CUSTOM AIR PRODUCTS, WHICH HAS FURNISHED THEM IN CONFIDENCE UPON THE UNDERSTANDING AND CONDITION THAT ALL PERSONS, FIRMS OR CORPORATIONS RECEIVING SUCH DRAWINGS AND INFORMATION SHALL BY THE ACT OF RECEIVING THEM BE DEEMED TO HAVE AGREED: TO MAKE NO COPY, DUPLICATION, DISCLOSURE OR USE WHATSOEVER OF ALL OR ANY PART THEREOF EXCEPT AS EXPRESSLY AUTHORIZED IN WRITING BY CUSTOM AIR PRODUCTS: NOT TO GIVE, LEND OR OTHERWISE DISPOSE OF THIS DRAWING; AND TO RETURN THIS DRAWING PROMPTLY UPON REQUEST.

CERTIFIED AS BUILT

CHECKER: _____ DATE: _____

APPROVER: _____ DATE: _____

CAPS NO.: _____ DRAWING: 40T-CS-000

CUST. PO#: _____ SHEET: 1 OF 1

SIZE: B REV: 8

DESIGNER: ALEX BANNISTER DATE: 11/13/2016

CHECKER: _____ DATE: _____

APPROVER: _____ DATE: _____

CUSTOMER: _____

**460V/3PH/60HZ
MECHANICAL DESIGN
DESCRIPTION**



CUSTOM AIR PRODUCTS & SERVICES, INC.

35 Southbelt Industrial Drive • Houston, Texas 77047

(713) 460-9009 • Fax (713) 460-9499

www.customairproducts.com

SECTION

09

SPARE PARTS LIST

SUGGESTED SPARE PARTS

JOB #: 17F-0868		REVISION #: 0				
CUSTOMER: HERC						
PROJECT: 2018 FLEET						
ITEM #	DESIGNATION	BRAND	MODEL/PART #	DESCRIPTION	QTY	CAPS#
1	HEATER	TUTCO	DHD82307-117.0-3P	117 KW HEATER, 4 CIRCUITS , 460V/3P	1	
2	CONDENSER MOTOR	EMERSEN	8987VG	2 HP 460-3-60 INVERTER DUTY, 1200 RPM, W SHAFT GND & WATER SLINGER	1	
3	BLOWER	GREENHECK	24-APH-3-II-150	13,500 CFM PLENUM FAN W/15 HP 460-3-60 TEFC MOTOR 254T FRAME 1725 RPM	1	
4	CONDENSER FAN	LAU	F15E08-3026	10,000CFM @ 0.62"W.C AND 1140RPM; 30" DIA.	1	
5	LOUVERS	GREENHECK	F-200783	LOUVER, ESJ-202, 23"W X 62"H	1	
6	FAN GUARD	RFC	F-308802	FAN GUARD 8 EYELETS 3" SIZE CENTER DISC 36"	1	
7	FILTERS	GLASFLOSS	20"x20"x2"	30% PLEATED	1	
8	FD	SPORLAN	C-307-S	FILTER DRYER, 7/8" SWEAT	1	
9	SG	SPORLAN	SA-17S	SIGHT GLASS, 7/8" SWEAT	1	
10	FILTER DRIER VALVE	SPORLAN	EBVT-1070	BALL VALVE, 7/8"ODF	1	
11	SUCTION VIBRA - SORBER	PACKLESS	VAFS-10 (1-3/8")	1-3/8" VIBRA-SORBER, STAINLESS STEEL	1	
12	DISCHARGE VIBRA - SORBER	PACKLESS	VAFS-9 (1-1/8")	1-1/8" VIBRA-SORBER, STAINLESS STEEL	1	
13	HGBV	SPORLAN	HGB-8	HOT GAS BYPASS VALVE, 7/8" SWEAT	1	
14	HGLV BALL VALVE	SPORLAN	EBVT-1070	BALL VALVE, 7/8" ODF	1	
15	HPS	SUPCO	SHP610420	HIGH PRESSURE SWITCH AUTO RESET (OPEN 610, CLOSE 420)	1	
16	LPS	SUPCO	SLP75100	LOW PRESSURE SWITCH AUTO RESET (OPEN 75, CLOSE 100)	1	
17	F 1, 2 (XFMR PRIMARY FUSES)	MERSEN	ATQR3	FUSE 3A 600V CLASS CC TIME DELAY	1	
18	F 3 (XFMR SECONDARY FUSE 120V)	MERSEN	ATQR7	FUSE 7A 600V CLASS CC TIME DELAY	1	
19	FU 4 (XFMR SECONDARY FUSE 24V)	MERSEN	ATQR30	FUSE 30A 600V CLASS CC TIME DELAY	1	
20	F 5, 6 (COMPRESSOR PROTECTION MODULE)	MERSEN	ATM3	FUSE 3A, 600V CLASS CC FAST-ACTING	1	
21	F 7-9 (PHASE MONITOR)	MERSEN	ATQR1/4	FUSE 1/4A, 600V CLASS CC TIME DELAY	1	
22	F 10-12 (EF FAN VFD FUSE)	MERSEN	AJT50	FUSE 50A 600V CLASS J TIME DELAY	1	
23	F 13-15 (CF FAN VFD FUSE)	MERSEN	ATDR30	FUSE 30A 600V CLASS CC TIME DELAY	1	
24	F16 -24 (HEATER)	MERSEN	AJT60	FUSE,60A, 600V, CLASS J	1	
25	EVAPORATOR FAN VFD	ABB	ACS310-03U-25A4-4+J400	15HP VARIABLE FREQUENCY DRIVE 460/3/60, 25.4A	1	
26	CONDENSER FAN VFD	ABB	ACS310-03U-13A8-4+J400	7.5HP VARIABLE FREQUENCY DRIVE 460/3/60, 13.8A	1	
27	LINE REACTOR 1	MTE	RL-02502	15HP LINE REATOR, 3% IMPEDANCE, 460V/3P/60HZ	1	
28	LINE REACTOR 2	MTE	RL-01202	7.5HP LINE REATOR, 3% IMPEDANCE, 460V/3P/60HZ	1	
29	SYSTEM SWITCH	SQUARE D	ZB4BD2	2 POSITION SWITCH	1	
30	CONTROL SELECTOR SWITCH	SQUARE D	ZB4BD3	3 POSITION SWITCH	1	
31	CONTACT BLOCK	SQUARE D	ZBE101	CONTACT BLOCK, 1NO	1	
32	CONTACT BLOCK	SQUARE D	ZBE102	CONTACT BLOCK, NC, 22MM	1	
33	CONTACT BLOCK	SQUARE D	ZB4BZ009	CONTACT BLOCK/MOUNTING COLLAR 22MM, ZB4	1	
34	HC1, HC2, HC3 (HEAT CONTACTORS)	SQUARE D	LC1D40B7	CNTR, 40A, 3P, 24VAC	1	
35	CC1, CC2 (COMPRESSOR CONTACTORS)	SQUARE D	LC1D40B7	3-POLE CONTACTOR 40A INDUCTIVE, 24VAC COIL	1	
36	CF1, 2, 3-MS	SQUARE D	GV2ME08	MMP 600V 4AMP	1	
37	AUX-CONTACT BLOCK	SQUARE D	LADN11	AUXILIARY CONTACT BLOCK FOR HEAT CONTACTOR, 1NO, 1NC	1	
38	TRANSFORMER	ABB	X4500PSF1	CCT, 500VA, 460/230/208X115/24	1	
39	TRANSFORMER	ABB	TPTC-2002	XFMR TOUCH SAFE COVER	1	
40	THERMOSTAT	VICONICS	VT7600B5000	THERMOSTAT, PROGRAMMABLE MULTI STAGE(2HEAT/2 COOL)	1	
41	THERMOSTAT SENSOR	VICONICS	S1010E1000	REMOTE INDOOR SENSOR, 10K OHMS	1	
42	EVAPORATOR RUN COMMAND RELAY	EATON	D2RR2T	RELAY, DPDT, 24VAC	1	
43	DH1, 2	EATON	D2RR4T	RELAY, 4PDT, 24VAC COIL	1	
44	TEMPERATURE CONTROL	CHROMALOX	6040 A00001	24VAC POWER SUPPLY, STANDARD INPUT, 4-20MA OUTPUT	1	
45	TEMPERATURE SENSOR	WATLOW	RJBTA030BB20	RTD SENSOR - 1/4 O.D; 20' LEAD WIRE LENGHT	1	
46	MUFFIN FAN	ORION	OA172AP-11-1TB XC	ENCLOSURE MUFFIN FAN	1	
47	FILTER	ORION	GRM172-45	ENCLOSURE FILTER	1	
48	GUARD	ORION	G172-10H	FAN GUARD	1	

49	GUARD	ORION	WVG172M	WIRE MESH GUARD	1	
50	ANALOG INTERFACE	ACI	6N1-ISO	ANALOG INTERFACE, 6 INPUTS, 1 OUTPUT	1	
51	HM	REDINGTON	3410-1000	AC/DC HOUR METER 2-HOLE 1/4" ROUND, SPADE TERMINALS, NON-RESET	1	
52	PDS	DWYER	1910-0	DIFFERENTIAL PRESSURE SWITCH, 0.15-0.5"W.C, SPDT CONTACT	1	
53	DISCHARGE PRESSURE TRANSDUCER	JOHNSON CONTROLS	P499ACP-107C	750PSI, 4-20mA TRANSDUCER	1	
54	POWER ON LIGHT	SQUARE D	XB4BVB3	PILOT LIGHT, GREEN, 24VAV/DC, LED, 22MM, COMPLETE	1	
55	PHASE INCORRECT LIGHT	SQUARE D	XB4BVB4	PILOT LIGHT, RED, 24VAV/DC, LED, 22MM, COMPLETE	1	
56	HEAT LIGHT	SQUARE D	XB4BVB5	PILOT LIGHT, AMBER, 24VAV/DC, LED, 22MM, COMPLETE	1	
57	COOL LIGHT	SQUARE D	XB4BVB6	PILOT LIGHT, BLUE, 24VAV/DC, LED, 22MM, COMPLETE	1	
58	MAIN CB 250A	SQUARE D	LDL36400U31X	MCCB, 400A, 600V, LI, 18KA@480V	1	
59	PM	SQUARE D	RM35TF30	PHASE MONITOR	1	
60	LOGO!	SIEMENS	6ED1052-1HB00-0BA8	LOGO! 24RCE, 8 INPUTS, 4 OUTPUTS, 24VAC	1	
61	LOGO! EXPANSION MODULAR	SIEMENS	6ED1055-1HB00-0BA2	LOGO! EXPANSION MODULE DM8 24R, 4 INPUTS, 4 OUTPUTS, 24VAC	1	
62	POTENTIOMETER 10K Ohm	C3 CONTROLS	POTO10k-TBW	ROTARY POTENTIOMETER 10K Ohm WITH ROTARY KNOB	1	
63	HOUR METER	REDINGTON	3410-0000	ETM,10-300VDC,20-300VAC,NON-RESET,DR MT SQUARE	1	